

# GENERAL NOTES

- CONTRACTOR TO FURNISH AND MAINTAIN TEMPORARY SANITARY FACILITIES AS REQUIRED DURING CONSTRUCTION.
- ALL REQUIRED WORK AND ALL REPAIR OF DAMAGES ON AND OFF PUBLIC PROPERTY (SIDEWALK, CURB, STREET, ETC.) OCCURRING AS RESULT OF CONSTRUCTION PROCEDURE, ETC., SHALL BE DONE ACCORDING TO GOVERNING REGULATIONS, SPECIFICATIONS, ETC., MATCH AND PATCH THIS WORK TO BE CONSISTENT WITH SAID ADJOINING CONDITIONS AT NO EXTRA COST.
- PROVIDE AND COORDINATE SITE PLUMBING, DRAINAGE, ELECTRICAL, TELEPHONE, ETC., WORK TO PROVIDE COMPLETE OPERATING SYSTEMS. ALL NECESSARY WORK INVOLVING EXISTING CURBS, STREETS, SIDEWALKS, ETC., TRENCHING, BACK FILLING, REPAIRING, ETC., INSIDE AND OUTSIDE OF PROPERTY LINES SHALL BE PROVIDED.
- FOR UTILITIES, SEE PLUMBING AND ELECTRICAL DRAWINGS FOR BUILDING WORK. SEE CIVIL AND ELECTRICAL DRAWINGS FOR SITEWORK.
- ALL ROOF DRAINS DISCHARGING RAIN WATER WITHIN 25 FEET OF PROPERTY LINES AT STREETS, SHALL BE CONDUCTED TO DRAINAGE WITHOUT SHEET FLOW OVER SIDEWALKS. SEE BUILDING, PLUMBING AND CIVIL DRAWINGS.
- PROVIDE PEDESTRIAN PROTECTION BARRICADES AND / OR CANOPIES AS REQUIRED BY THE LOCAL AUTHORITIES, OR AS NECESSARY FOR PEDESTRIANS SAFETY.
- ALL WORK MATERIALS, METHODS, ETC., SHALL CONFORM TO ALL GOVERNING CODES, REGULATIONS AND AGENCIES.
- GOVERNING CODES AND FIRE DEPARTMENT FIELD INSPECTOR SHALL DICTATE SIZE, TYPE, QUANTITY AND LOCATIONS OF REQUIRED PORTABLE FIRE EXTINGUISHERS. (NIC)
- GLASS AND GLAZING TO COMPLY WITH 16 CFR PART 2101 OF CONSUMER PRODUCT SAFETY COMMISSION.
- CONTRACTOR SHALL VISIT THE JOBSITE AND VERIFY ALL DIMENSIONS AND CONDITIONS THEREON BEFORE COMMENCING WORK. REPORT ANY DISCREPANCIES AND / OR POTENTIAL PROBLEMS TO THE ARCHITECT IN WRITING.
- DURING CONSTRUCTION, CONTRACTOR SHALL PROVIDE AND MAINTAIN FIRE EXTINGUISHERS AS REQUIRED BY THE FIRE DEPARTMENT FIELD INSPECTOR.
- CONTRACTOR SHALL PROVIDE ALL CEILING OR WALL ACCESS PANELS (OR ACCESS DOORS) AS REQUIRED BY THE AIR CONDITIONING, PLUMBING AND ELECTRICAL SYSTEMS.
- ALL DIMENSIONS SHOWN ARE TO CENTER LINE OF COLUMNS AND BEAMS, FACE OF STUDS UNLESS OTHERWISE NOTED.
- ALL OCCUPIABLE AREAS OF THE BUILDING SHALL BE MECHANICALLY VENTILATED. THE VERY MINIMUM AIR CHANGE PER HOUR SHALL NOT BE LESS THAN TWO PER HOUR. SEE MECHANICAL.
- ALL TOILET ROOMS SHALL BE VENTILATED WITH 5 MINUTE AIR CHANGE BY MECHANICAL MEANS. SEE MECHANICAL DRAWINGS.
- SIGN CONTRACTOR TO OBTAIN SEPARATE PERMITS FROM BUILDING DEPARTMENT FOR INSTALLATION OF ALL SIGNS AS REQUIRED BY LOCAL CODE.
- THESE DOCUMENTS WILL INDICATE THE GENERAL SCOPE OF THE PROJECT IN TERMS OF ARCHITECTURAL DESIGN CONCEPT, THE DIMENSIONS, MAJOR ARCHITECTURAL ELEMENTS AND THE TYPE OF STRUCTURAL, MECHANICAL AND ELECTRICAL SYSTEMS, AS SCOPE DOCUMENTS, THE DRAWINGS DO NOT NECESSARILY INDICATE OR DESCRIBE ALL WORK REQUIRED FOR FULL PERFORMANCE AND COMPLETION OF THE PROJECT. ON THE BASIS OF THE GENERAL SCOPE DESCRIBED, ANY WORK OR MATERIALS NOT DIRECTLY NOTED IN THE CONTRACT DOCUMENTS, BUT NECESSARY FOR THE INTENT THEREOF, ARE IMPLIED AND ARE TO BE PROVIDED FOR AS IF SPECIFICALLY DESCRIBED.

# STARBUCKS LA HABRA

## 541 E. WHITTIER BLVD. LA HABRA CA 90631

# VICINITY MAP

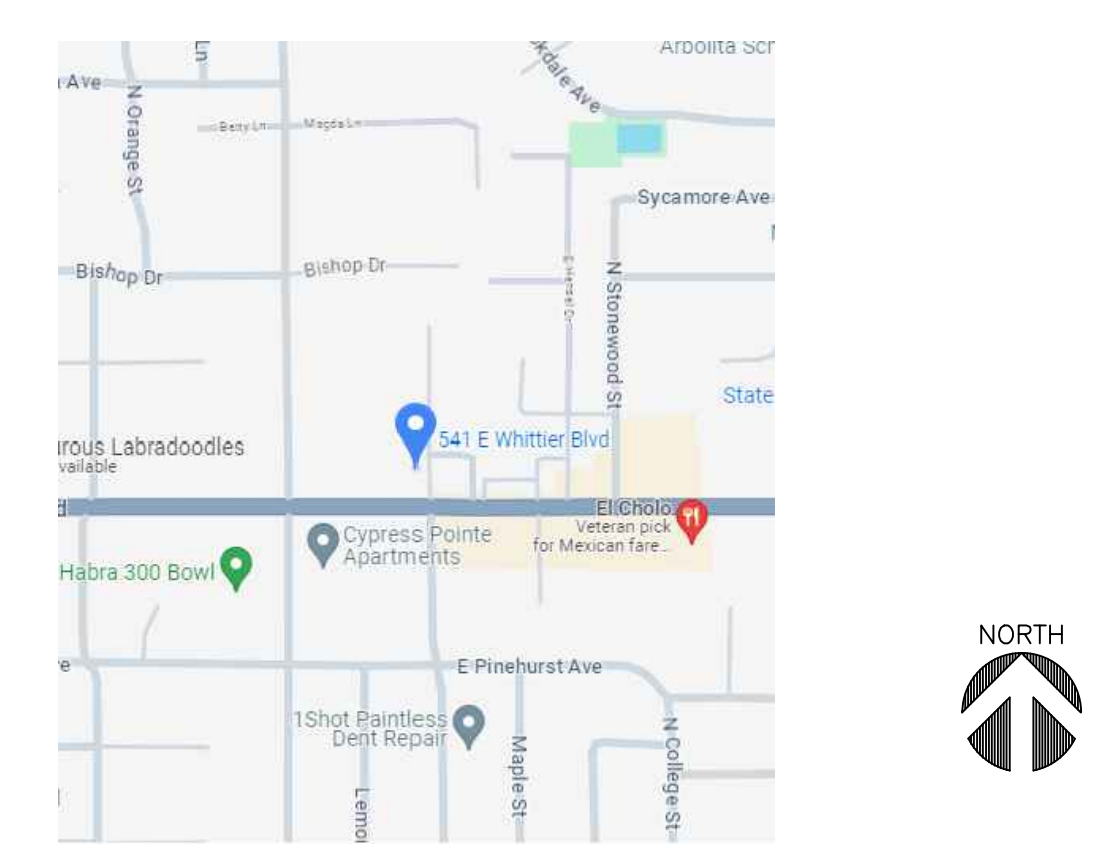

# FIRE & SECURITY ORDINANCES & REQUIREMENTS

- A. EXTERIOR DOORS (EXCLUDING GLASS PATIO DOORS) AND DOORS LEADING FROM GARAGE AREAS INTO DWELLING SHALL BE OF SOLID CORE NO LESS THAN ONE-AND-THREE-EIGHTHS-INCH THICKNESS.
- B. EXTERIOR DOORS LEADING FROM OUTSIDE TO INTERIOR OF ATTACHED GARAGE SHALL BE OF SOLID CORE NO LESS THAN ONE-AND-THREE-EIGHTHS-INCH THICKNESS.
- C. EXTERIOR DOORS (EXCLUDING GLASS PATIO DOORS) AND DOORS LEADING FROM GARAGE AREAS INTO DWELLING SHALL BE A SELF-CLOSING LOCK WITH DEADLATCH AND A DEADBOLT LOCK WITH ONE-INCH THROW.
- D. THE LOCKING DEVICE ON MAIN ENTRANCE DOORS SHALL BE SO CONSTRUCTED THAT BOTH DEADBOLT AND DEADLATCH CAN BE RETRACTED BY A SINGLE ACTION OF THE INSIDE DOORNOB.
- E. THE DEADLATCH LOCK AND DEADBOLT LOCK SHALL BE KEYPED ALIKE (ONE KEY WILL FIT BOTH LOCKS).
- F. PAIRS OF DOORS SHALL HAVE FLUSH BOLTS WITH A MINIMUM THROW OF FIVE-EIGHTHS INCH AT THE HEAD AND FOOT (FLOOR AND CEILING) OF THE INACTIVE LEAF.
- G. DOORSTOP ON A WOODEN JAMB FOR AN IN-SWING DOOR SHALL BE OF ONE PEICE CONSTRUCTION WITH THE JAMB JOINED BY A RABBIT.
- H. NON-REMOVABLE PIN OR INTERLOCKING STUD-TYPE HINGE SHALL BE USED IN PINTYPE HINGE WHICH IS ACCESSIBLE FROM THE OUTSIDE WHEN THE DOOR IS CLOSED.
- I. CYLINDERS SHALL BE SO DESIGNED OR PROTECTED THAT THEY CANNOT BE GRIPED BY PLIERS OR OTHER WRENCHING DEVICES.
- J. LOCKS SHALL BE PROVIDED ON ALL SLIDING PATIO DOORS.
- K. SLIDING PATIO GLASS DOORS OPENING ONTO PATIOS OR BALCONES WHICH ARE LESS THAN ONE STORY ABOVE GRADE OR ARE OTHERWISE ACCESSIBLE FROM THE OUTSIDE SHALL HAVE THE MOVEABLE SECTION OF THE DOOR SLIDING ON THE INSIDE OF THE FIXED PORTION OF THE DOOR OR POSSESS AN APPROVED SECONDARY LOCK MOUNTED ON INTERIOR OF MOVEABLE SECTION.
- L. THE LOCK BOLTS ON ALL GLASS PATIO DOOR SHALL ENGAGE THE STRIKE SUFFICIENTLY TO PREVENT ITS BEING DISENGAGED BY ANY POSSIBLE MOVEMENT OF THE DOOR WITHIN THE SPACE OR CLEARANCE PROVIDED FOR INSTALLATION AND OPERATION. THE STRIKE AREA SHALL BE OF MATERIAL ADEQUATE TO MAINTAIN EFFECTIVENESS OF BOLTS STRENGTH.
- M. ALL MAIN ENTRY DOORS SHALL BE EQUIPPED WITH APPROVED DEVICES SO THAT THE OCCUPANT HAS A VIEW OF THE AREA IMMEDIATELY OUTSIDE THE DOOR WITHOUT OPENING THE DOOR. SUCH VIEW MAY BE PROVIDED BY A DOOR VIEWER OR VIEW PORTS INT THE DOOR OR ADJOINING WALL. VIEW PORTS SHALL BE SMALL SO AS TO PREVENT A PERSON OUTSIDE THE DOOR FROM REACHING THE REQUIRED LOCKING DEVICE OR THE WINDOWS THE VIEW PORTS SHALL BE LOCATED MORE THAN FORTY INCHES FROM SUCH LOCKS WHEN THE DOOR IS IN THE CLOSED POSITION. SLIDING WINDOWS SHALL BE DESIGNED TO PREVENT REMOVAL BY RAISING OF THE MOVING PANEL FROM THE TRACK WHILE IN A CLOSED OR PARTIALLY OPEN POSITION. LOUVERED WINDOWS, EXCEPT THOSE ABOVE THE FIRST STORY SHALL NOT BE PERMITTED.
- O. EACH OVERHEAD OR SLIDING DOOR SHALL MEET THE FOLLOWING STANDARDS:
  - a. OVERHEAD OR SLIDING DOORS SHALL BE SECURED WITH A CYLINDER LOCK, PADLOCK WITH HARDENED STEEL SHACKLE, METAL SLIDE BAR, BOLT OR EQUIVALENT WHEN NOT OTHERWISE LOCKED BY ELECTRIC POWER OPERATION.
  - b. THE LOCK SHALL BE DESIGNED AND INSTALLED SO AS PREVENT THE LOCKING MECHANISM FROM BEING DEFEATED BY PRYING OR SHIFTING THE DOOR FROM SIDE TO SIDE.
  - c. A CYLINDER GUARD SHALL BE INSTALLED ON EACH MORTISE BEYOND THE FACE OF THE DOOR OR IS OTHERWISE ACCESSIBLE TO GRIPPING TOOLS.

- P. THE FOLLOWING STANDARDS AS TO LIGHTING OF RESIDENTIAL UNITS SHALL BE FOLLOWED:
  - a. EACH PARKING LOT/OR CARPORT PROVIDING MORE THAN PARKING SPACES SHALL BE PROVIDED WITH A MAINTAINED MINIMUM OF FOOTCANDLE OF LIGHT ON THE PARKING SURFACE DURING THE HOURS OF DARKNESS.
  - b. LIGHTING FIXTURES SHALL BE SO ARRANGED AS TO ILLUMINATE LIGHT UNIFORMLY OVER THE PARKING SURFACE.
  - c. LIGHTS SHALL BE SECURED TO DISCOURAGE TAMPERING
- Q. SMOKE ALARM SHALL BE INTERCONNECTED HARD-WIRED WITH BATTERY BACKUP AND SHALL BE INSTALLED IN ACCORDANCE WITH CRC R314 CARBON MONOXIDE ALARM SHALL BE INTERCONNECTED, HARD-WIRED WITH BATTERY BACKUP, AND INSTALLED IN ACCORDANCE WITH CRC R315

# HEALTH DEPARTMENT NOTE

- ALL EQUIPMENT SHALL MEET NATIONAL SANITATION FOUNDATION DESIGN AND INSTALLATION OR ITS EQUIVALENT.
- LIGHT FIXTURES IN FOOD PREPARATION, OPEN FOOD STORAGE AND UTENSIL WASHING AREAS ARE TO BE PROTECTED AGAINST BREAKAGE THROUGH THE USE OF PLASTIC SLEEVES, SHATTER PROOF BULBS AND OR OTHER APPROVED DEVICES.
- EXTERIOR DOORS SHALL BE SELF-CLOSING AND FIT TO A MAXIMUM 1/4" AT THE BASE AND SIDES
- PROVIDE PERMANENTLY MOUNTED SINGLE SERVICE SOAP AND TOWEL DISPENSERS AT ALL HAND SINKS.
- TOILET ROOMS AND DRESSING ROOM DOORS SHALL BE SELF-CLOSING.
- SEAL ALL CRACKS AND CREVICES IN COUNTERS, CABINETS, AROUND METAL FLASHING, SINK BACK SPLASHES, AND AROUND PIPES AND CONDUITS WITH A NON-HARDENING SILICONE SEALANT.
- PROVIDE AN AREA OR CABINET FOR STORAGE OF CLEANING EQUIPMENT AND SUPPLIES AWAY FROM FOOD PREPARATION, UTENSIL WASHING, AND FOOD STORAGE AREAS.
- A ROOM, ENCLOSURE, OR DESIGNATED AREA SHALL BE PROVIDED WHERE EMPLOYEES MAY CHANGE AND STORE CLOTHES.
- PRIOR TO STARTING CONSTRUCTION, SUBMIT THREE(3) SETS OF PLANS TO YOUR LOCAL BUILDING AND SAFETY DEPARTMENT FOR REVIEW, APPROVAL, AND NECESSARY PERMITS.
- EXHAUST AND MAKE-UP AIR SYSTEMS SHALL BE ELECTRICALLY INTERLOCKED WITH ONE SWITCH.
- DRY FOOD STORAGE OF AT LEAST 96 LINEAR FT. OF NSF CERT. STORAGE SHELVES SHALL BE PROVIDED
- AT LEAST 50 FT-CANDLE LIGHTING SHALL BE PROVIDED IN KITCHEN AND ANY FOOD PREP AREA
- EXTERIOR WINDOWS SHALL BE FIXED(NON-OPERABLE OR MOVABLE)
- RESTROOM DOORS SHALL BE SELF-CLOSING AND RESTROOM VENTILATION IS LIGHT SWITCH ACTIVATED IF THE VENTILATION IS NOT CONTINUOUSLY ACTIVE
- ALL EQUIPMENT SHALL BE EASILY MOVABLE (E.G. ON CASTERS), ON 6" LEGS / CLEARANCE FROM THE FLOOR OR SEALED TO MIN. 4" SOLID MASONRY ISLAND WITH MIN. 3/8" COVER BASE. IF ON AN ISLAND, IT SHALL OVERHANG THE BASE AT LEAST 2" BUT NO MORE THAN THE HEIGHT OF THE ISLAND.

# PROJECT SUMMARY

PROJECT NAME: & ADDRESS	STARBUCKS 541 E. WHITTIER BLVD. LA HABRA CA 90631
APN	303-101-32
OWNER NAME: & ADDRESS	541 WHITTIER LLC 541 E. WHITTIER BLVD. LA HABRA CA 90631
DESIGNER:	L J CONSTRUCTION 15902 HALLIBURTON RD., #182 HACIENDA HEIGHTS, CA 9174 626-581-8885 LIC. #799342
SCOPE OF WORK:	DEMO EXISTING BUILDING, BUILD NEW STARBUCKS WITH DRIVE THRU
TYPE OF CONSTRUCTION:	V
OCCUPANCY GROUP:	B
BUILDING USAGE:	RESTAURANT
FIRE SPRINKLER:	YES
PROPERTY AREA:	18,964 SQ. FT.
BUILDING AREA RESTAURANT:	1,200 SQ. FT.
PARKING REQUIRED: 1 SPACE/250 S. FT. 1 SPACE/15 SEATS 1,200 / 250 = RESTAURANT SEATING = 5 + 3 = 8 SPACES	
PARKING PROVIDED	
ACCESSIBLE SPACES STANDARD SPACES	2 + 8 = 10 SPACES
LOT COVERAGE: 1200/18964=6.32%	
LANDSCAPE AREA= 4405	
PARKING LOT AREA=5645	CALCULATION: 4405/5645=78%

- NOTES:
- ALL CONSTRUCTION ALONG WHITTIER BLVD. WILL REQUIRE A PERMIT FROM CALTRANS, INCLUDING RED CURB, SIDEWALK & DRIVEWAY RELOCATION WORK.
  - ALL CONSTRUCTION WITHIN THE PUBLIC RIGHT-OF-WAY WILL REQUIRE A PUBLIC WORKS PERMIT WHICH CAN BE OBTAIN FROM ENGINEERING. INCLUDING RE CURB ALONG CHESTNUT AVE.

# SHEET INDEX

A-1.0 COVER SHEET / NOTE	A-6.0 COLOR ELEVATION
A-2.0 PERSPECTIVE PLAN	A-6.1 PATIO FURNITURE DETAIL
A-3.0 DEMOLITION PLAN / SITE PLAN	A-7.0 TRASH ENCLOSURE
A-4.0 PROPOSED SITE PLAN	A-8.0 ADA PARKING DETAIL / POLE LIGHT FIXTURE
A-4.1 FLOOR PLAN	A-8.1 GREASE INTERCEPTOR
A-4.2 UTILITY PLAN	L-1.0 COLOR LANDSCAPE PLAN
A-5.0 ELEVATION	STARBUCKS DRIVE THRU MANAGEMENT PLAN

# CONTRACTOR NOTES

- BEFORE SUBMITTING THE BID, THE CONTRACTOR SHALL CAREFULLY EXAMINE THE PLANS PERTAINING TO THIS WORK. CONTRACTOR SHALL VISIT THE SITE AND FULLY INFORM HIMSELF AS TO ALL CONDITIONS AND LIMITATIONS APPLYING TO THIS WORK. HE SHALL ESTIMATE AND INCLUDE IN HIS BID A SUM SUFFICIENT TO COVER THE COST OF ALL LABOR AND MATERIALS TO ACCOMPLISH THE INTENT OF THESE PLANS, AND NO SUBSEQUENT ALLOWANCE WILL BE MADE TO THIS CONTRACTOR BECAUSE OF HIS NEGLECT IN COMPLYING WITH THESE REQUIREMENTS.
- THE CONTRACTOR SHALL OBTAIN PERMITS AS REQUIRED BY THE GOVERNING AUTHORITIES FOR CONSTRUCTION.
- ELECTRICAL, MECHANICAL AND PLUMBING SYSTEMS SHALL BE DONE BY THE CONTRACTOR. THE CONTRACTOR SHALL PREPARE AND SUBMIT PLANS, AND OBTAIN PERMITS AS REQUIRED BY THE GOVERNING AUTHORITIES FOR PLAN CHECK AND CONSTRUCTION.
- THE CONTRACTOR SHALL PROCURE IN THE OWNER'S NAME, AND CHARGES FOR INSTALLATION OF THE WATER AND GAS METERS AND ALL PIPING FROM MAIN TO SAID METERS.
- THE CONTRACTOR SHALL SEND PROPER NOTICES, MAKE ALL NECESSARY ARRANGEMENTS AND PERFORM ALL SERVICES REQUIRED IN THE MAINTENANCE OF ALL PUBLIC UTILITIES.
- THE CONTRACTOR SHALL REQUIRE SUCH COOPERATION OF THE VARIOUS TRADES AS WILL BE NECESSARY TO COMPLETE EACH AND EVERY PART OF THE WORK, EVEN THOUGH NOT SPECIFICALLY INDICATED, NOTED OR DETAILED ON THE DRAWINGS OR SPECIFICATIONS.
- DIMENSIONS AND CONDITIONS AT THE JOBSITE SHALL BE VERIFIED BY THE CONTRACTORS. DISCREPANCIES IN THE DRAWINGS OR BETWEEN THE DRAWINGS AND ACTUAL FIELD CONDITIONS OR CODE REQUIREMENTS SHALL BE REPORTED TO THE ARCHITECT. CORRECTED DRAWINGS OR INSTRUCTIONS SHALL BE ISSUED BY THE ARCHITECT PRIOR TO THE INSTALLATION OF ANY WORK.
- IT IS THE RESPONSIBILITY OF THE CONTRACTOR TO ADHERE TO ALL APPLICABLE REQUIREMENTS OF CAL-OLSA PERTAINING TO CONSTRUCTION SAFETY.
- THE CONTRACTOR SHALL PROTECT ALL PUBLIC PAVING, STREETS AND SIDEWALKS, AND SHALL MAKE ALL NECESSARY REPAIRS AT HIS OWN EXPENSE.
- THE CONTRACTOR SHALL PROTECT ALL PRIVATE PROPERTY, ROADS AND WALLS, AND SHALL MAINTAIN THEM DURING THE COURSE OF THE WORK, AND SHALL REPAIR ALL DAMAGES TO THE WORK, AND SHALL REPAIR ALL DAMAGES AT HIS OWN EXPENSE.
- THE CONTRACTOR SHALL, AND HEREBY DOES, WARRANT ALL WORK PERFORMED BY HIM FOR THE PERIOD OF ONE YEAR FROM THE TIME OF FINAL OCCUPANCY. WORK SHALL INCLUDE ALL MATERIALS, FIXTURES, EQUIPMENT AND LABOR.
- DAMAGE (HOLES, OPENINGS, SCRATCHES ETC.) RESULTING FROM DEMOLITION OR CONSTRUCTION ACTIVITIES REQUIRED FOR THIS PROJECT SHALL BE REPAIRED (PATCHED / REPLACED ) TO MATCH AND BE UNNOTICABLE FROM THE EXISTING ADJACENT SURFACE.
- CONTRACTOR SHALL PROVIDE ENOUGH SHORINGS AND BRACINGS TO SUPPORT ALL CONSTRUCTION LOADS.
- SHOP DRAWINGS AND DETAILS SHALL BE APPROVED PRIOR TO INSTALLATION.
- CONTRACTOR TO PROVIDE COMPLETE APPROVED WATER PROOFING SYSTEM AND MEMBRANES IN ALL KITCHEN AREA, WAITER STATION, BAR AREA, SERVICE AREA, RESTROOM AREA AND ANY OTHER AREA SUBJECT TO ROUTINE MAINTENANCE, WASHING AND CLEANING WORKS. FLOOR SURFACE SHALL BE GRADED TO PROVIDE MIN. SLOPE AS REQUIRED BY CODES TOWARD FLOOR DRAINING.

# FIRE DEPARTMENT NOTES

- FIRE SUPPRESSION SYSTEM (ANSUL) CONTRACTOR SHALL SUBMIT PLAN, OBTAIN PERMIT PRIOR TO THE COMMENCEMENT OF WORK FROM FIRE DEPARTMENT.
- LOCATION & CLASSIFICATION OF FIRE EXTINGUISHERS SHALL BE IN ACCORDANCE WITH C.F.C. STANDARDS AND PLACEMENT IS SUBJECT TO APPROVAL OF FIRE INSPECTOR.
- STORAGE, DISPENSING, OR USE OF ANY FLAMMABLE AND COMBUSTIBLE LIQUIDS, FLAMMABLE, AND COMPRESSED GASES, AND OTHER HAZARDOUS MATERIAL SHALL COMPLY WITH CALIFORNIA FIRE CODE REGULATIONS. THE STORAGE AND USE OF HAZARDOUS MATERIALS SHALL BE APPROVED BY THE FIRE AUTHORITY PRIOR TO ANY MATERIALS BEING STORED OR USED ON SITE. A SEPARATE PLAN SUBMITTAL IS REQUIRED PRIOR TO THE STORAGE AND USE OF HAZARDOUS MATERIALS.
- BUILDING(S) NOT APPROVED FOR HIGH-PILED STOCK (MATERIAL IN CLOSELY PACKED PILES OR ON PALLETS, OR IN RACKS WHERE THE TOP OF STORAGE EXCEEDS 12'-0" IN HEIGHT, AND 6'-0" FOR GROUP A PLASTIC AND CERTAIN OTHER HIGH HAZARD COMMODITIES. HIGH-PILES STOCK SHALL BE APPROVED BY THE FIRE DEPARTMENT PRIOR TO MATERIAL BEING STORED ON SITE. A SEPARATE PLAN SUBMITTAL IS REQUIRED FOR HIGH STORAGE IN ACCORDANCE
- ALL WEATHER ACCESS ROAD SHALL BE APPROVED BY THE GOVERNING FIRE DEPARTMENT AND IN PLACE BEFORE ANY COMBUSTIBLE MATERIALS ARE PLACED ON SITE. ACCESS ROADS SHALL BE CLEAR OF OBSTRUCTIONS.
- ACCESS GATES SHALL BE IN COMPLIANCE WITH CALIFORNIA FIRE CODE 2016 AND LOCAL GOVERNING FIRE DEPARTMENT GUIDELINES. A SEPARATE PLAN SUBMITTAL AND APPROVAL BY FIRE DEPARTMENT.
- PLANS OF NEW OR MODIFICATIONS TO EXISTING FIRE PROTECTION, DETECTION, ALARM, OR MONITORING SYSTEMS) SHALL BE APPROVED BY THE FIRE DEPARTMENT PRIOR TO INSTALLATION. A SEPARATE PLAN SUBMITTAL AND APPROVAL BY FIRE DEPARTMENT IS REQUIRED PRIOR TO THE COMMENCEMENT OF ANY WORK.
- A LETTER OF INTENDED USE FOR THE STRUCTURE(S) MAY BE REQUIRED BY THE FIRE INSPECTOR.
- WHEN THE PROJECT INVOLVES THE CONSTRUCTION OF A NEW STRUCTURE OR AN ADDITION TO AN EXISTING STRUCTURE, PLAN AND DOCUMENTATION FOR FIRE DEPARTMENT ACCESS, HYDRANT LOCATION, WATER AVAILABILITY AND FIRE LANE MARKINGS SHALL BE SUBMITTED TO AND APPROVED BY THE FIRE DEPARTMENT PRIOR TO THE APPROVAL OF ARCHITECTURAL PLAN. FIRE DEPARTMENT APPROVED SITE PLAN SHALL BE SUBMITTED WITH THE ARCHITECTURAL PLANS.
- IN STRUCTURES OF UNDETERMINED USE, THE MINIMUM FIRE SPRINKLER DESIGN DENSITY REQUIRED SHALL BE ORDINARY HAZARD GROUP 2 WITH A DESIGN AREA OF 3,000 SQUARE FEET.
- AN AUTOMATIC EXTINGUISHING SYSTEM SHALL BE PROVIDED TO PROTECT COMMERCIAL TYPE FOOD HEAT PROCESSING EQUIPMENT THAT PRODUCES GREASE-LADEN VAPORS. A SEPARATE PLAN SUBMITTAL IS REQUIRED FOR THE INSTALLATION OF THE SYSTEM AND SHALL BE IN ACCORDANCE WITH C.F.C.
- ALTERATIONS TO FIRE SPRINKLERS WERE NOT CONSIDERED IN THIS REVIEW. ARE PERMITTED SEPARATELY AND WILL REQUIRE A SEPARATE SUBMITTAL.
- MIN. 6 INCHES SUITE NUMBERS SHALL BE PROVIDED ON FRONT AND REAR DOORS.

# ADDITIONAL NOTES

- PLUMBING DRAIN WASTE AND VENT AND/OR MECHANICAL DUCTING AND/OR ELECTRICAL WIRING DIAGRAMS OR DRAWINGS MAY BE REQUIRED BY THE FIELD INSPECTOR AND WILL BE PROVIDED UPON REQUEST. ELECTRICAL LOAD CALCULATIONS MAY BE REQUIRED BY THE FIELD INSPECTOR AND WILL BE PROVIDED UPON REQUEST.
- THE FOLLOWING A & B. SHALL BE PROVIDED TO THE BUILDING FIELD INSPECTOR BEFORE ANY FOUNDATION INSPECTION WILL BE PERFORMED. ITEM C SHALL BE PROVIDED BEFORE THE SHEAR AND ROOF INSPECTION. ITEM D SHALL BE PROVIDED BEFORE A FRAME INSPECTION WILL BE PERFORMED.
  - 2.1. BUILDING SETBACKS TO PROPERTY LINES AND PAD ELEVATION(S) MUST BE VERIFIED BY A SURVEYOR. THIS MUST BE IN THE FORM OF A PROFESSIONAL REPORT, STAMPED AND SIGNED BY THE RESPONSIBLE PARTY. THE REPORT MUST STATE THAT THE BUILDING IS IN SUBSTANTIAL COMPLIANCE TO THE APPROVED PLANS. THIS REPORT MUST BE SUBMITTED TO THE FIELD INSPECTOR AT TIME OF FOUNDATION INSPECTION.
  - 2.2. PAD COMPACTION MUST BE VERIFIED BY A SOILS ENGINEER. THIS MUST BE IN THE FORM OF A PROFESSIONAL REPORT, STAMPED AND SIGNED BY THE RESPONSIBLE PARTY. THE REPORT MUST STATE THAT THE BUILDING IS IN SUBSTANTIAL COMPLIANCE TO THE APPROVED SOILS REPORT. THIS REPORT MUST BE SUBMITTED TO THE FIELD INSPECTOR AT TIME OF FOUNDATION INSPECTION.
  - 2.3. FINISH FLOOR ELEVATIONS MUST BE VERIFIED BY A SURVEYOR. THIS MUST BE IN THE FORM OF A PROFESSIONAL REPORT, STAMPED AND SIGNED BY THE RESPONSIBLE PARTY. THIS REPORT MUST STATE THAT THE BUILDING IS IN SUBSTANTIAL COMPLIANCE TO THE APPROVED PLANS.
  - 2.4. ELEVATION OF HIGHEST POINT OF ANY ROOF RIDGE OR ROOF PROJECTION MUST BE VERIFIED BY A SURVEYOR (CUSTOM HOMES ONLY). THIS MUST BE IN THE FORM OF A PROFESSIONAL REPORT, STAMPED AND SIGNED BY THE RESPONSIBLE PARTY. THE REPORT MUST STATE THAT THE BUILDING IS IN SUBSTANTIAL COMPLIANCE TO THE APPROVED PLANS.
- ALL HOLD DOWN AND ANCHOR BOLTS TO BE IN PLACE AT TIME OF INSPECTION.
- A SEPARATE CIRCUIT FOR A GARBAGE DISP. AND DISHWASHER.
- WHERE PENETRATIONS OCCUR THAT THEY COMPLY W/ 2320.11.7.11.9.11.1012.4. CUTTING, NOTCHING AND BORED HOLES.

# BUILDING CODES

- ALL CONSTRUCTION TO COMPLY W/ LOCAL CODES & ORDINANCES & THE FOLLOWING:
- APPLICABLE BUILDING CODES:
- ALL PLANS TO COMPLY WITH T-24 AND THE FOLLOWING:
- 2022 CALIFORNIA BUILDING CODE (CBC)
  - 2022 CALIFORNIA RESIDENTIAL GREEN BUILDING STANDARDS CODE. (CRC)
  - 2022 CALIFORNIA MECHANICAL CODE (CMC)
  - 2022 CALIFORNIA PLUMBING CODE (CPC)
  - 2022 CALIFORNIA ELECTRICAL CODE (CEC)
  - 2022 CALIFORNIA FIRE CODE (CFC)
  - 2022 CALIFORNIA ENERGY CODE

# REVISIONS

- △
- △
- △
- △
- △
- △

L J CONSTRUCTION  
Space Planning, Interior Design, Construction  
15902 A. HALLIBURTON RD., #182  
HACIENDA HEIGHTS, CA 91745  
(626) 9577738 LIC. #799342  
Email: [lj@lconstruction.com](mailto:lj@lconstruction.com)  
www.lconstruction.com



Hong Chuen Chao

# COVER SHEET / NOTES

STARBUCKS  
541 E. WHITTIER BLVD., LA HABRA 90631

Date: 07/15/2023

Scale: AS SHOWN

Drawn: JC

Job:

Sheet

A-1.0



Google Earth

REVISIONS

- ①
- ②
- ③
- ④
- ⑤
- ⑥

L.J. CONSTRUCTION  
 Space Planning, Interior Design, Construction  
 15802 A. HALLIBURTON RD., #182  
 HACIENDA HEIGHTS, CA 91745  
 (626) 9677738 LIC. #798342  
 info@ljconstruction.com  
 DESIGNER/CONTRACTOR



HongChuenChao

PERSPECTIVE PLAN

STARBUCKS  
 541 E. WHITTIER BLVD., LA HABRA 90631

Date: 07/15/2023  
 Scale: AS SHOWN  
 Drawn: JC  
 Job:

Sheet  
 A-2.0

PERSPECTIVE PLAN



### LEGEND

--- PROPERTY LINE  
- - - TO DEMOLISH

### KEY NOTES

1 TO BE DEMO

NORTH

**DEMO PLAN**

SCALE: 1/8"=1'-0"

1

REVISIONS
①
②
③
④
⑤
⑥
⑦
⑧
⑨
⑩
⑪
⑫
⑬
⑭
⑮
⑯
⑰
⑱
⑲
⑳
㉑
㉒
㉓
㉔
㉕
㉖
㉗
㉘
㉙
㉚
㉛
㉜
㉝
㉞
㉟
㊱
㊲
㊳
㊴
㊵
㊶
㊷
㊸
㊹
㊺
㊻
㊼
㊽
㊾
㊿
①
②
③
④
⑤
⑥
⑦
⑧
⑨
⑩
⑪
⑫
⑬
⑭
⑮
⑯
⑰
⑱
⑲
⑳
㉑
㉒
㉓
㉔
㉕
㉖
㉗
㉘
㉙
㉚
㉛
㉜
㉝
㉞
㉟
㊱
㊲
㊳
㊴
㊵
㊶
㊷
㊸
㊹
㊺
㊻
㊼
㊽
㊾
㊿
①
②
③
④
⑤
⑥
⑦
⑧
⑨
⑩
⑪
⑫
⑬
⑭
⑮
⑯
⑰
⑱
⑲
⑳
㉑
㉒
㉓
㉔
㉕
㉖
㉗
㉘
㉙
㉚
㉛
㉜
㉝
㉞
㉟
㊱
㊲
㊳
㊴
㊵
㊶
㊷
㊸
㊹
㊺
㊻
㊼
㊽
㊾
㊿
①
②
③
④
⑤
⑥
⑦
⑧
⑨
⑩
⑪
⑫
⑬
⑭
⑮
⑯
⑰
⑱
⑲
⑳
㉑
㉒
㉓
㉔
㉕
㉖
㉗
㉘
㉙
㉚
㉛
㉜
㉝
㉞
㉟
㊱
㊲
㊳
㊴
㊵
㊶
㊷
㊸
㊹
㊺
㊻
㊼
㊽
㊾
㊿
①
②
③
④
⑤
⑥
⑦
⑧
⑨
⑩
⑪
⑫
⑬
⑭
⑮
⑯
⑰
⑱
⑲
⑳
㉑
㉒
㉓
㉔
㉕
㉖
㉗
㉘
㉙
㉚
㉛
㉜
㉝
㉞
㉟
㊱
㊲
㊳
㊴
㊵
㊶
㊷
㊸
㊹
㊺
㊻
㊼
㊽
㊾
㊿
①
②
③
④
⑤
⑥
⑦
⑧
⑨
⑩
⑪
⑫
⑬
⑭
⑮
⑯
⑰
⑱
⑲
⑳
㉑
㉒
㉓
㉔
㉕
㉖
㉗
㉘
㉙
㉚
㉛
㉜
㉝
㉞
㉟
㊱
㊲
㊳
㊴
㊵
㊶
㊷
㊸
㊹
㊺
㊻
㊼
㊽
㊾
㊿
①
②
③
④
⑤
⑥
⑦
⑧
⑨
⑩
⑪
⑫
⑬
⑭
⑮
⑯
⑰
⑱
⑲
⑳
㉑
㉒
㉓
㉔
㉕
㉖
㉗
㉘
㉙
㉚
㉛
㉜
㉝
㉞
㉟
㊱
㊲
㊳
㊴
㊵
㊶
㊷
㊸
㊹
㊺
㊻
㊼
㊽
㊾
㊿
①
②
③
④
⑤
⑥
⑦
⑧
⑨
⑩
⑪
⑫
⑬
⑭
⑮
⑯
⑰
⑱
⑲
⑳
㉑
㉒
㉓
㉔
㉕
㉖
㉗
㉘
㉙
㉚
㉛
㉜
㉝
㉞
㉟
㊱
㊲
㊳
㊴
㊵
㊶
㊷
㊸
㊹
㊺
㊻
㊼
㊽
㊾
㊿
①
②
③
④
⑤
⑥
⑦
⑧
⑨
⑩
⑪
⑫
⑬
⑭
⑮
⑯
⑰
⑱
⑲
⑳
㉑
㉒
㉓
㉔
㉕
㉖
㉗
㉘
㉙

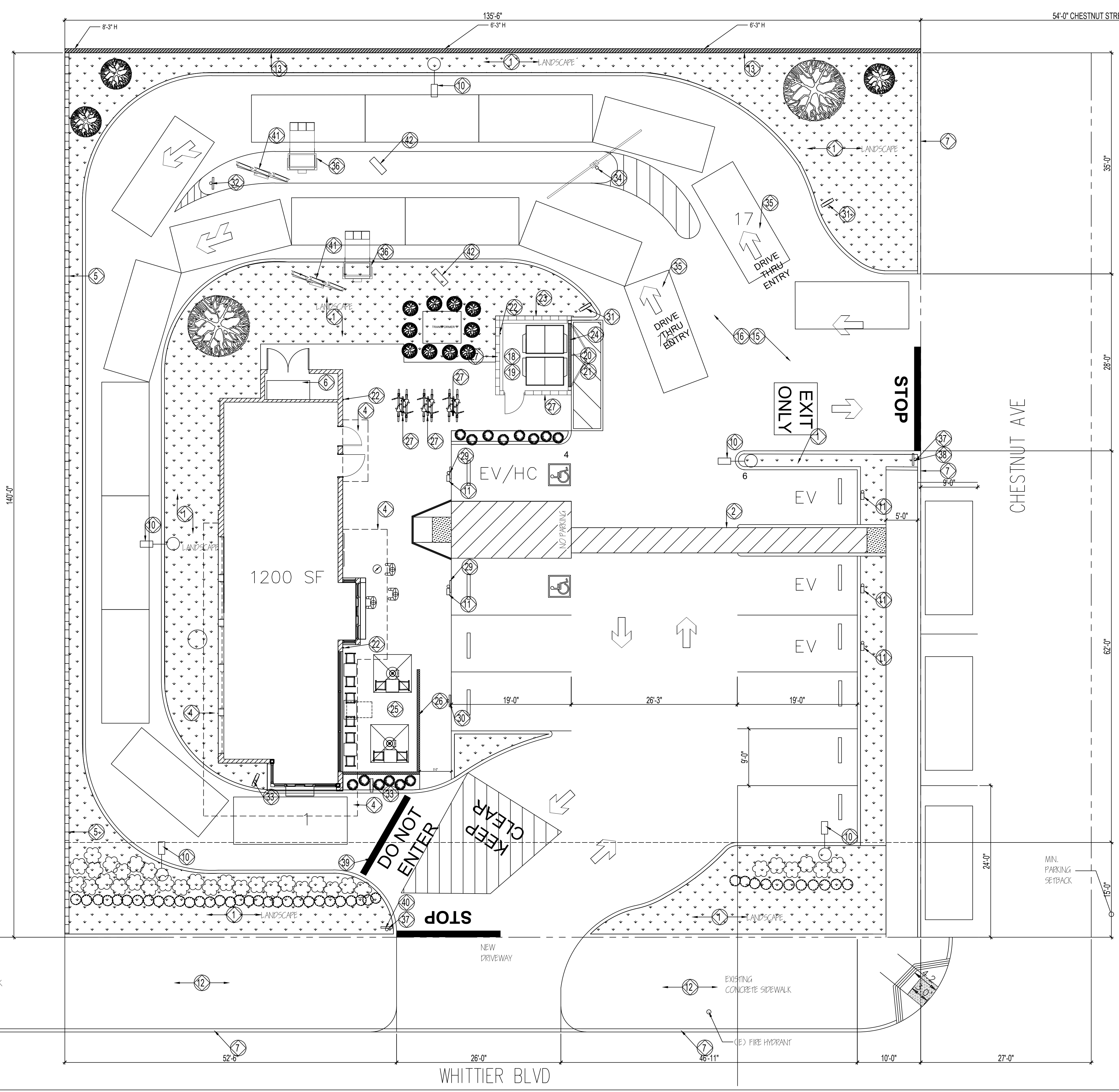

### LEGEND

- PROPERTY LINE
- INTERIOR NON BEARING WALL
- EXTERIOR WALL
- LANDSCAPE
- EXISTING CMU WALL TO REMAIN

### KEYED NOTES

1. LANDSCAPE AREA
  2. ACCESSIBLE PATH OF TRAVEL
  3. 6" CONCRETE CURB, TYPICAL
  4. CANOPY (ABOVE)
  5. EXISTING 4" H WALL TO BE REMAIN, ADD NEW BLOCKS TO 6"
  6. ELECTRICAL CABINET AND METER LOCATION
  7. 6" CONCRETE CURB
  8. LOCATION FOR SITE TRANSFORMER
  9. HANDRAIL
  10. SITE LIGHT POLE
  11. EV CHARGER
  12. CONTINUATION TO PUBLIC TRANSIT
  13. EXISTING CMU WALL TO BE REMAIN
- PARKING AND DRIVE-THRU**
14. BOLLARDS - NON-ILLUMINATED: PROVIDE NON-ILLUMINATED, PROTECTIVE BOLLARDS IN FRONT OF THE PRE-MENU BOARD, ORDER POINT AND PICK-UP WINDOW BUMP-OUT
  15. BOLLARDS - ILLUMINATED: THESE BOLLARDS ARE TO BE USED FOR SAFETY AND WAY FINDING AWAY FROM THE BUILDING
  16. DRIVE THRU LANE: ENSURE EASY INGRESS AND EGRESS FROM MAIN CUSTOMER TRAFFIC. DO NOT BLOCK PARKING MINIMUM (1) CAR LENGTH PRIOR TO ENTERING TRAFFIC AFTER PAY/PICKUP. AVOID LOCATING UNSIGHTLY ITEMS, SUCH AS GREASE TRAPS OR TRASH ENCLOSURES, IN OR NEAR THE DRIVE THRU LANE
  17. QUEUE LENGTH: RECOMMEND (1) CAR QUEUE FOR DRIVE THRU LANE (SUBJECT TO JURISDICTIONAL REQUIREMENTS)
    - A. CAR STACK: PREFERRED (7) CARS FROM ORDER POINT TO PICK-UP WINDOW. ALLOWS PARTNERS TIME NEEDED TO PREPARE CUSTOMER ORDER AND MAINTAIN SPEED OF SERVICE
    - B. ORDER TAIL: PREFERRED (4) CARS, MIN. (3) CARS, FROM LEASE LINE TO ORDER POINT. ALLOWS POTENTIAL VIEWING OF PRE-MENU BOARD AND MINIMIZES TRAFFIC BACK-UP INTO STREET, DRIVEWAY, OR PARKING AREA
- TRASH ENCLOSURE**
18. LOCATION: TRASH AND RECYCLING AREA TO BE LOCATED NO MORE THAN 300 FEET FROM THE SERVICE DOOR. ENCLOSURE SHALL NOT BE UNDER OBSTRUCTIONS WHICH LIMIT ACCESS
  19. PATHWAY: PATHWAY FROM THE PREMISES TO THE ENCLOSURE SHALL BE WELL LIT. ACCESS PATHWAY FROM REAR SERVICE DOOR TO TRASH ENCLOSURE SHALL BE RAMPED (MAX. 1:20) TO ALLOW ROLLING ACCESS
  20. HAULER ACCESS: TRASH ENCLOSURE POSITIONED SO THAT HAULER CAN ACCESS CONTAINERS BY EITHER FRONT LOAD OR REAR LOAD REMOVAL. TYPICALLY LEAVE 40-45 FEET UNOBSTRUCTED AREA FOR 90-DEGREE TURN CHECK REQUIREMENTS WITH LOCAL TRASH REMOVAL SERVICES
  21. SITE PAVING: PROVIDE 6" THICK SEALED CONCRETE PAVING AT TRASH ENCLOSURE. TO EXTEND 12'-0" FROM FRONT EDGE OF ENCLOSURE TOWARDS HAULER ACCESS POINT
  22. HOSE BIB: INCLUDE DRAIN AND HOSE BIB IF ENCLOSURE LOCATED MORE THAN 50 FEET FROM REAR SERVICE DOOR. PATIO, SEATING AND SITE AMENITIES
  23. TO PROVIDE CREEPING FIG VINES ON TRASH ENCLOSURE WALLS TO DEFER GRAFFITI
  24. TRENCH DRAIN CONNECT TO SEWER LINE
- PATIO, SEATING AND SITE AMENITIES**
25. OPTIONAL PATIO AND SEATING: PROVIDE OPTIONAL OUTDOOR SEATING AREA, WITH EASY ACCESS FROM TO CAFE SPACE. PROVIDE EXTERIOR RATED SEATING, TABLES, AND ACCESSORIES AS SPECIFIED IN THE STARBUCKS DESIGN CATALOG. PROVIDE ACCESSIBLE SEATING, MIN. 5% OR PER LOCAL REQUIREMENTS
  26. RAILING AND SCREENING: PROVIDE RAILING, VEGETATED BUFFER, AND/OR SCREENING ELEMENT BETWEEN PATIO AND VEHICULAR LANE. INCLUDE ADDITIONAL SCREENING AS NEEDED TO REDUCE NOISE AND LIGHT TRANSFER TO ADJACENT SITES
  27. BIKE RACKS: INSTALL BIKE RACK(S) NEAR MAIN ENTRANCE TO ACCOMMODATE ALTERNATIVE TRANSIT TO THE SITE. LOCATE BIKE RACK AS TO LIMIT PEDESTRIAN DISRUPTION AND MAINTAIN ACCESSIBLE PROVISIONS OF THE SITE
  28. ACCESSIBLE PUBLIC RESTROOM TO SUPPORT EXTERIOR SEATING AS REQUIRED BY JURISDICTION. PROVIDE A SECURITY CODE OR OTHER LOCKING MECHANISM TO SECURE THE DOOR TO DETER VANDALISM
- SITE AND DRIVE-THRU (DT) SIGNAGE**
29. ACCESSIBLE PARKING SIGNAGE: PROVIDE SIGNAGE AS REQUIRED BY JURISDICTION
  30. PROVIDE SIGNAGE "ORDER PICK UP SHORT TERM PARKING"
  31. DRIVE THRU DIRECTIONAL SIGNAGE: SHOULD BE CLEARLY VISIBLE TO PROVIDE AN EXPERIENCE THAT IS SAFE, CONVENIENT, EFFICIENT, AND EASY TO NAVIGATE. ENSURE LANDSCAPING DOES NOT HINDER SIGNAGE VISIBILITY
  32. LANES MERGING
  33. DT DIRECTIONAL EXIT/THANK YOU SIGN: LOCATE AT EXIT OF DT LANE, ON PASSENGER SIDE, WITH "EXIT ONLY" SIDE FACING PARKING LOT. (DIMENSION LOCATION FROM CURB)
  34. CLEARANCE BAR: LOCATE AT ENTRANCE TO DT LANE. SET CLEARANCE HEIGHT BASED ON MINIMUM OBSTRUCTION HEIGHT ALONG PATH OF VEHICLE TRAVEL, INCLUDING BUILDING AWNINGS AND/OR ORDER POINT CANOPY. (DIMENSION 12" FROM CURB)
  35. WAY FINDING PAVEMENT GRAPHICS: HIGH VISIBILITY DIRECTIONAL GRAPHICS, HEAT-APPLIED OR PAINTED ON PAVEMENT. (DIMENSION LOCATION)
    - A. DOUBLE ARROWS: SPACE EVENLY WITHIN VEHICULAR CIRCULATION. DO NOT BLOCK PEDESTRIAN PATHS
    - B. ENTRY/EXIT ARROWS: CENTER WITHIN TYPICAL DT LANE. ALIGN EDGE OF GRAPHIC WITH CURB AND ENTRY/EXIT
  36. DIGITAL ORDER SCREEN WITH CANOPY: LOCATE ORDER POINT CENTERED ON THE 7'-CAR IN THE QUEUE. SITUATE ORDER POINT SO THAT THE MICROPHONE AND SPEAKER FACE AWAY FROM TRAFFIC, AND CARS CAN PULL UP CLOSE, AVOIDING TIGHT TURNS.
    - A. ALTERNATE: SPEAKER POST IS AVAILABLE IF NEEDED DUE TO SPACE CONSTRAINTS, LANDLORD REQUIREMENTS, SITE RESTRICTIONS, OR BUDGET.
  37. INSTALL SIGNAGE "STOP"
  38. INSTALL SIGNAGE "NO LEFT TURN"
  39. PAVEMENT GRAPHIC: DO NOT ENTER
  40. INSTALL SIGNAGE "RIGHT TURN ONLY"
- DIGITAL ORDER SCREEN (DOS) AND MENU**
41. MENU BOARD: THE 5-PANEL MENU BOARD IS THE PREFERRED STANDARD. LOCATE ADJACENT TO THE DOS. DO NOT LOCATE ON TURNING RADIUS. DO NOT OBSTRUCT VIEW OF MENU BOARD WITH DOS/CANOPY. CONSIDER SCREENING BEHIND MENU BOARD IF ADJACENT TO EXTERIOR SEATING, SIDEWALK, OR PEDESTRIAN WAY.
    - A. ALTERNATE: 3-PANEL BOARD IS AVAILABLE IF SITE RESTRICTIONS LIMIT USE OF 5-PANEL
  42. DT PRE-MENU: THE PREVIEW BOARD IS AVAILABLE IN WALL-MOUNTED AND FREE-STANDING OPTIONS. LOCATE 1-2 CAR LENGTHS BEFORE ORDER POINT TO MAXIMIZE INFLUENCE ON CUSTOMER PURCHASING BEHAVIOR.
    - A. ALTERNATE: IF NO SPACE IS AVAILABLE IN THE DT LANE, THIS ITEM CAN BE REMOVED.

REVISIONS
<b>L J CONSTRUCTION</b> Space Planning, Interior Design, Construction 15902 A. HALLIBURTON RD., #182 HACIENDA HEIGHTS, CA 91745 (626) 967-7738 LIC. #93642 @ljconstr.com DESIGNER/CONTRACTOR
<b>SITE PLAN</b>
<b>STARBUCKS</b> 541 E. WHITTIER BLVD., LA HABRA 90631
Date: 07/15/2023 Scale: AS SHOWN Drawn: JC Job: Sheet <b>A-4.0</b>

## SITE PLAN

SCALE: 1/8"=1'-0"

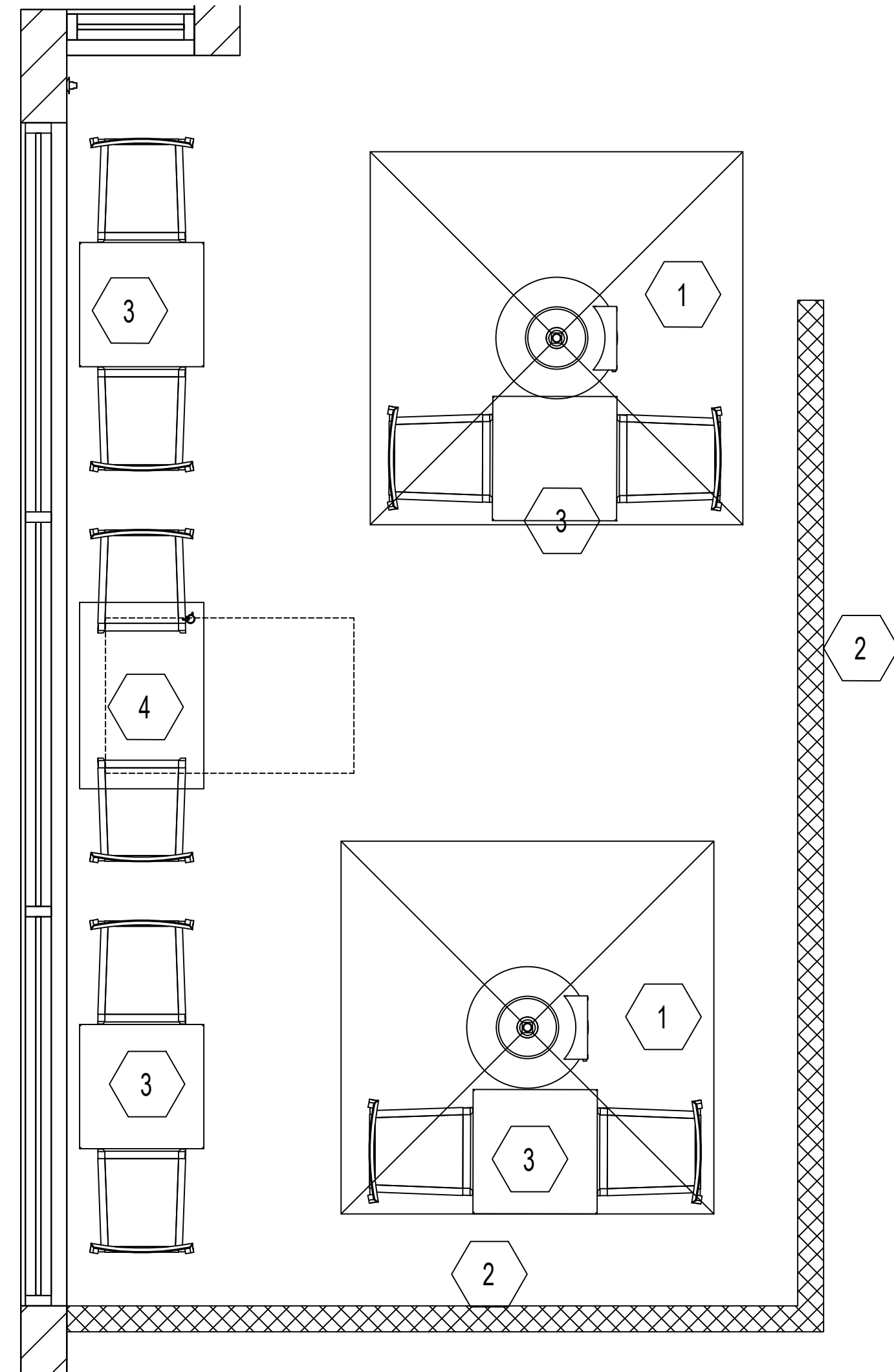

**LEGEND**

- 1 OUTDOOR UMBRELLA
- 2 RAILING
- 3 OUTDOOR FURNITURE
- 4 ADA OUTDOOR TABLE

**PATIO PLAN**

SCALE: 1/2"=1'-0"

2

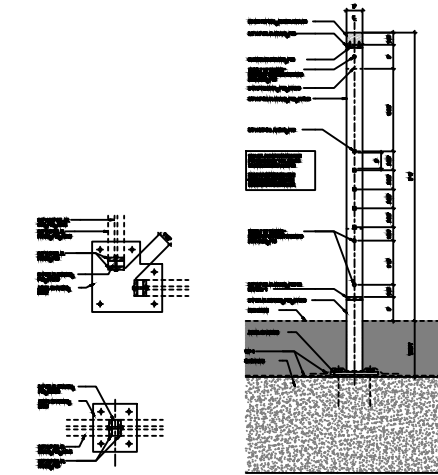

**RAILING SECTION & BASE PLATE**

SCALE: 1/2"=1'-0"

3

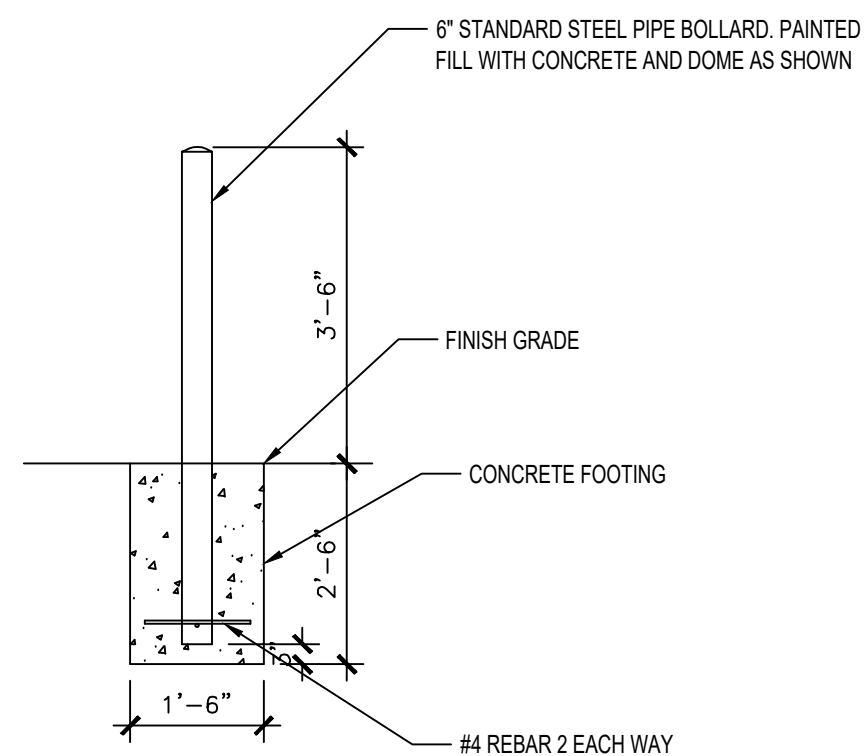

**BOLLARD DETAIL**

SCALE: N.T.S.

4

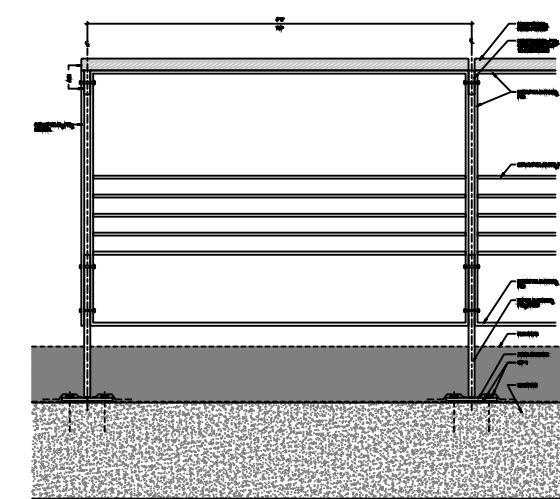

**RAILING ELEVATION**

SCALE: 1/2"=1'-0"

4

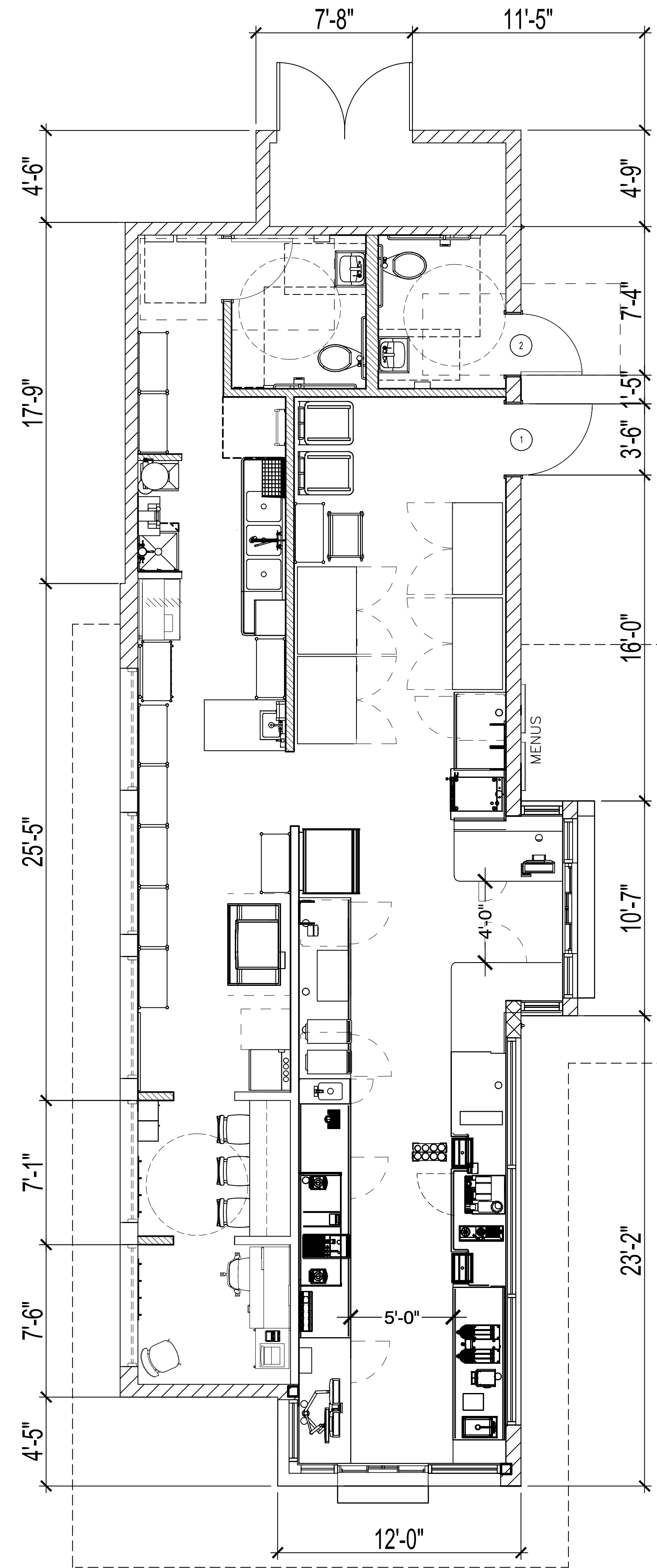

**LEGEND**

- EXTERIOR FULL HEIGHT WALL WITH INSULATION
- INTERIOR PARTITION WALL
- STOREFRONT
- DOOR NUMBER

**FLOOR PLAN (REFERENCE ONLY)**

SCALE: 1/4"=1'-0"

1



**REVISIONS**

1	
2	
3	
4	
5	
6	

**L.J. CONSTRUCTION**  
 Space Planning, Interior Design, Construction  
 15802 A. HALLIBURTON RD., #182  
 HACIENDA HEIGHTS, CA 91745  
 (626) 967-7738 LIC. #798642  
 info@ljconstruction.com  
 DESIGNER/CONTRACTOR

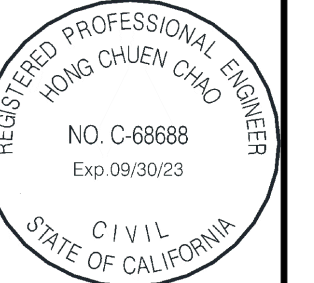

*Hong Chuen Chao*

**FLOOR PLAN**

**STARBUCKS**  
 541 E. WHITTIER BLVD., LA HABRA 90631

Date: 07/15/2023  
 Scale: AS SHOWN  
 Drawn: JC  
 Job:

Sheet  
**A-4.1**

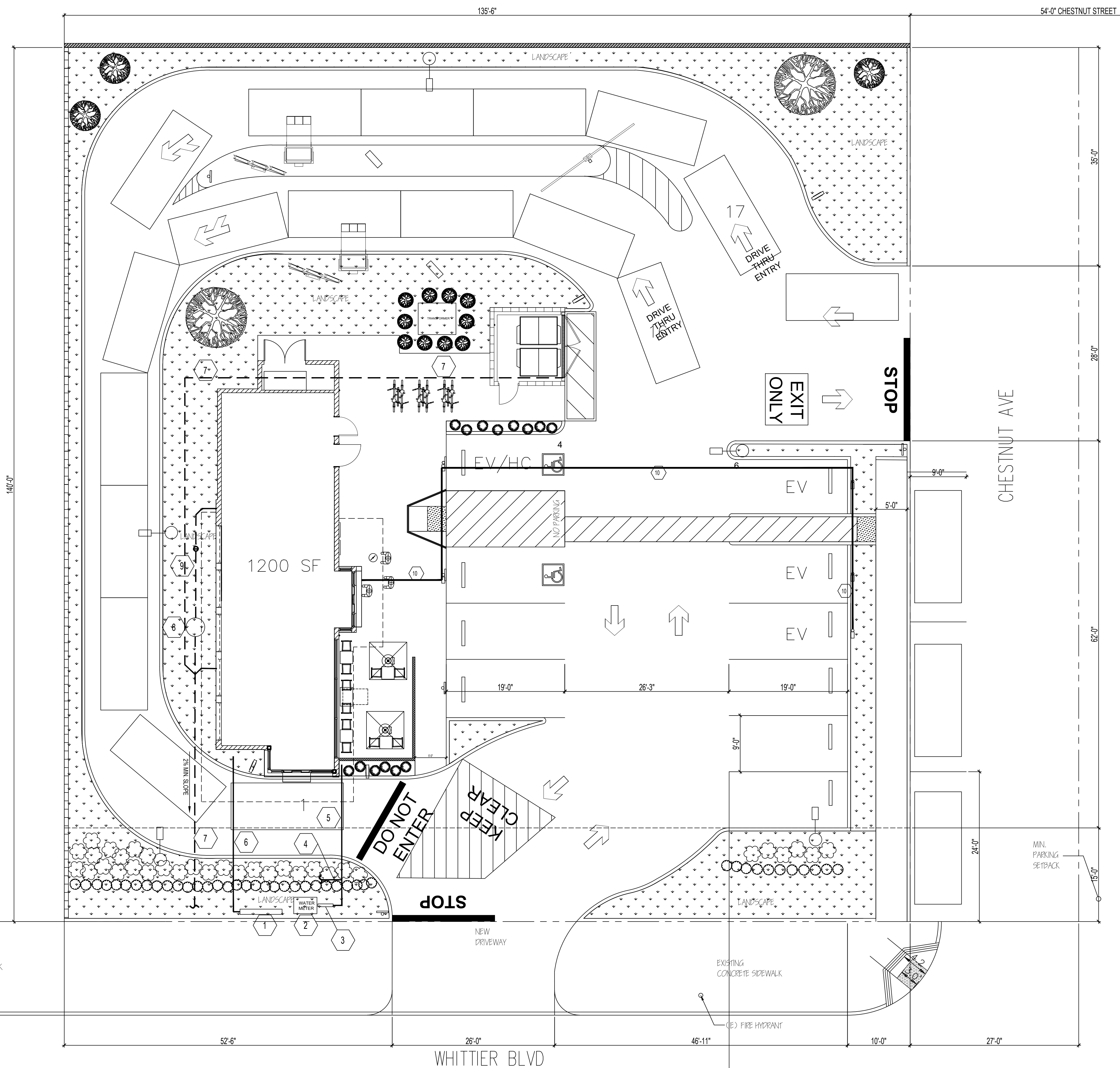

### LEGEND

- 1 CONST. 4" DCDA (DOUBLE DETECTOR ASSEMBLY) DETAIL ON FIRE FIRE SPRINKLER PLAN
- 2 INSTALL NEW 2" WATER METER WITH MAIN GATE VALVE IN CONC. VAULT, PER COUNTY STANDARD
- 3 CONST. 2" BACKFLOW PREVENTION ASSEMBLY
- 4 CONST. 1.5" WATER LATERAL FOR IRRIGATION USE
- 5 CONST. 2" WATER SUPPLY
- 6 CONST. 4" FIRE WATER SUPPLY
- 7 CONST. 4" SEWER LINE TO EXISTING SEWER MAIN
- 8 CONST. 75 GAL. GREASE INTERCEPTOR SEE DETAIL T-4.1
- 9 CONST. 4" GREASE SEWER
- 10 CONST. 1" CONDUIT FROM HOUSE PANEL WITH 40 AMP BREAKER TO EV CHARGER

REVISIONS
1
2
3
4
5
6

**L.J. CONSTRUCTION**  
 Space Planning, Interior Design, Construction  
 15802 A. HALLIBURTON RD., #182  
 HACIENDA HEIGHTS, CA 91745  
 (626) 987-7738 LIC. #798642  
 info@ljconstruction.com  
 DESIGNER/CONTRACTOR

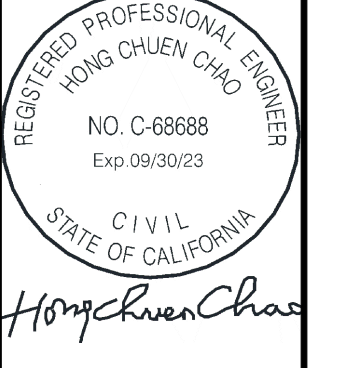

### UTILITY PLAN

**STARBUCKS**  
 541 E. WHITTIER BLVD., LA HABRA 90631

Date: 07/15/2023  
 Scale: AS SHOWN  
 Drawn: JC  
 Job:

Sheet  
**A-4.2**

### SITE PLAN



1

SCALE: 1/8"=1'-0"

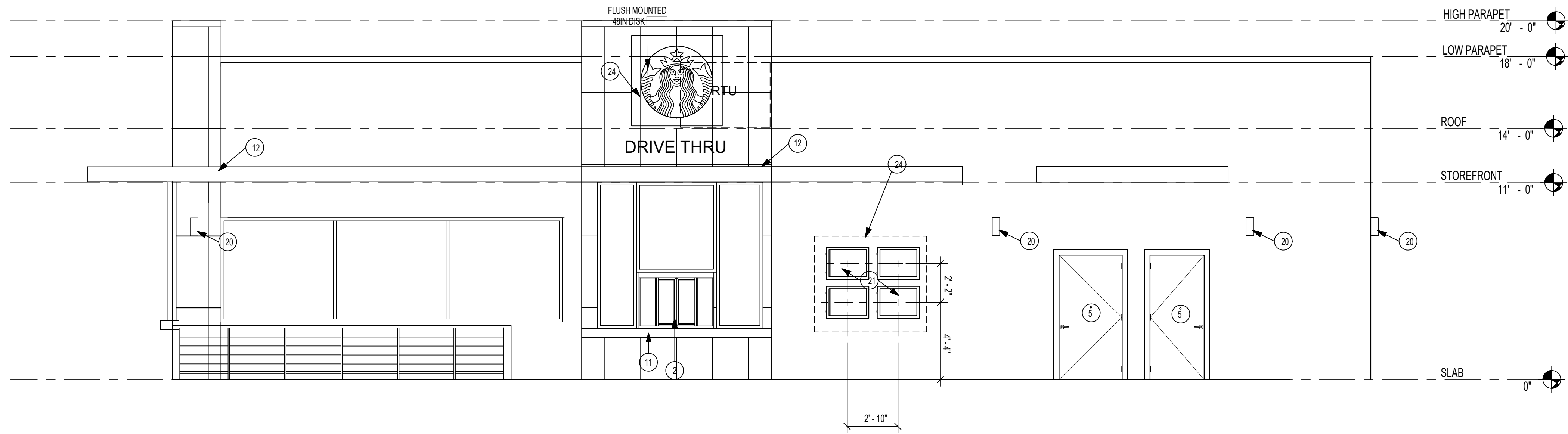

**EAST ELEVATION**

SCALE: 1/4"=1'-0"

1

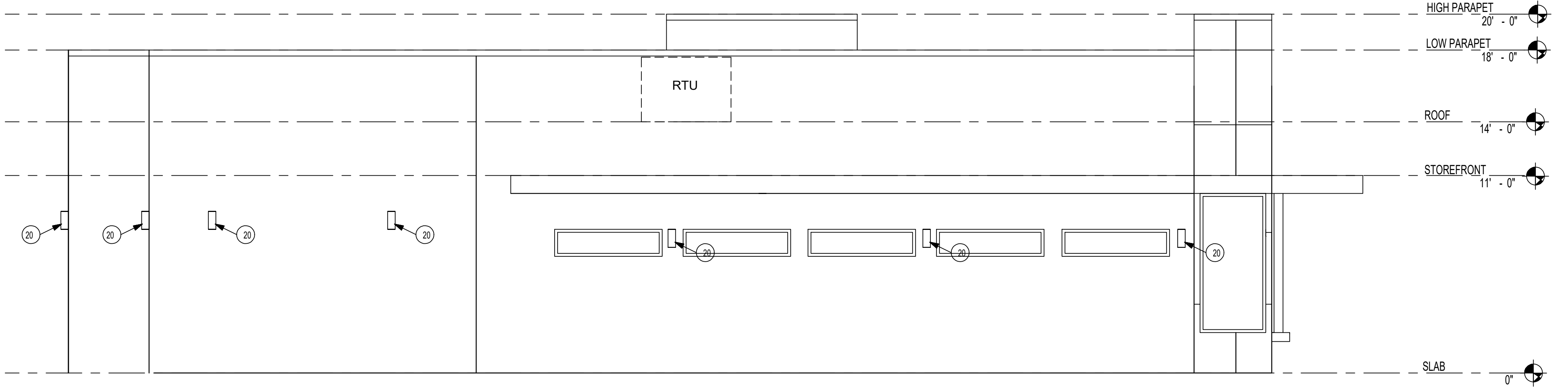

**WEST ELEVATION**

SCALE: 1/4"=1'-0"

2

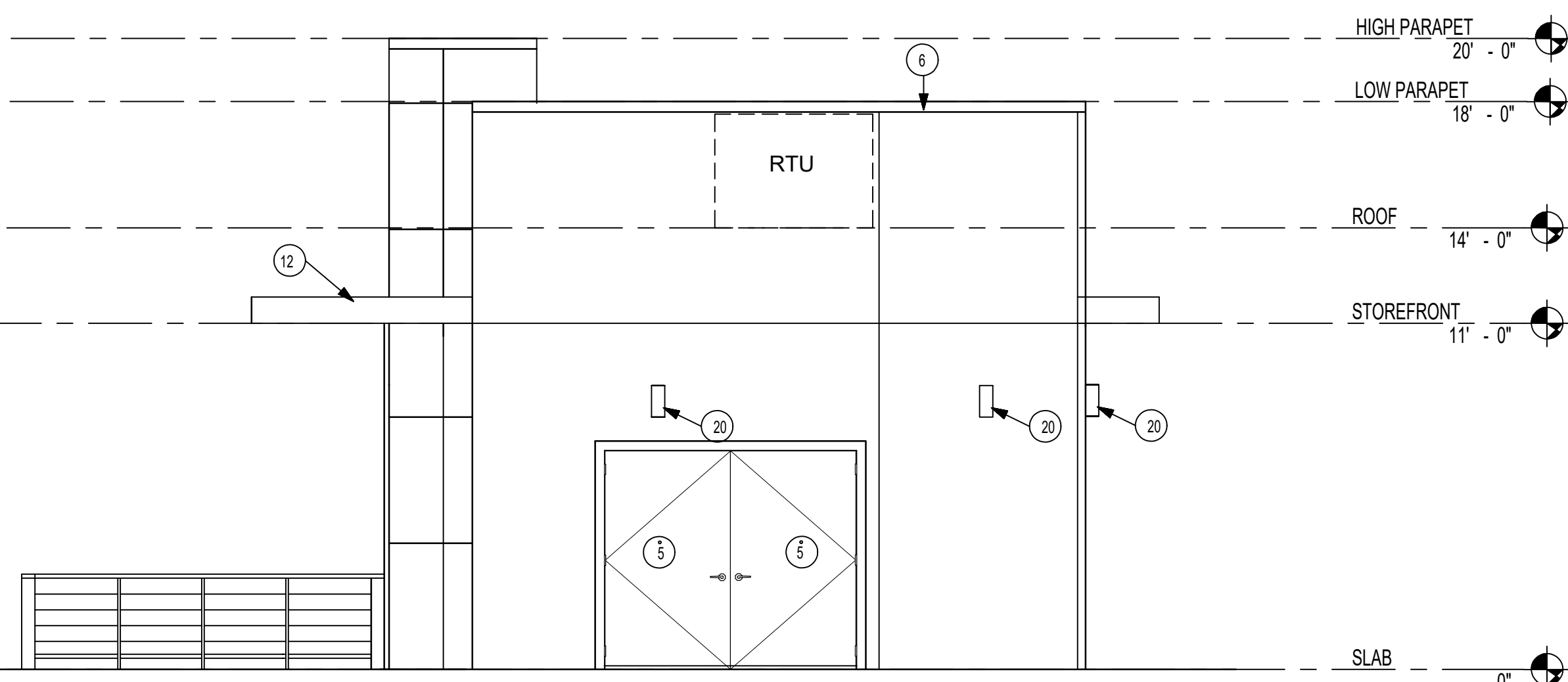

**NORTH ELEVATION**

SCALE: 1/4"=1'-0"

4

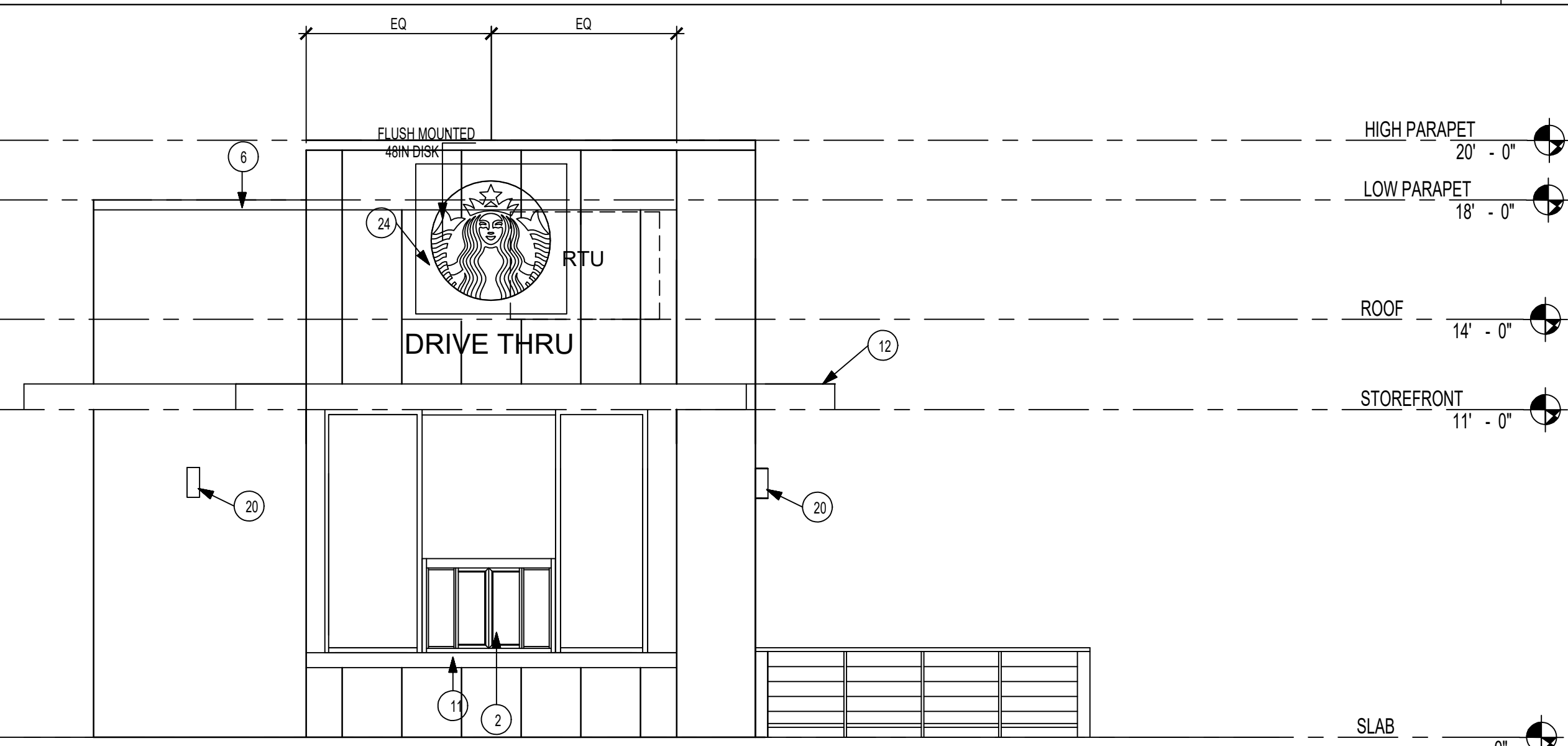

**SOUTH ELEVATION**

SCALE: 1/4"=1'-0"

3

**KEYED NOTES**

1. NON-ILLUMINATED PROTECTIVE BOLLARD
2. PRIMARY DRIVE THRU SERVICE WINDOW
3. SECONDARY WALK-UP SERVICE WINDOW
4. ELECTRICAL METER
5. SERVICE DOOR
6. PRE-FINISHED METAL COPING, TYPICAL
7. OUTLINE OF ROOF BEYOND
- STOREFRONT SYSTEM AND DOOR**
8. STOREFRONT: EXTEND GLAZING TO 9'-0" AFF. WITH TEMPERED GLAZING PER CODE.
9. STORE ADDRESS: PROVIDE 3" HIGH BLACK ACRYLIC STORE ADDRESS ON GLAZING ABOVE WALK-UP WINDOW.
10. DT WINDOW: PROVIDE READY ACCESS DT SERVICE WINDOW PER REGIONAL SPECIFICATION WINDOW AND AIR CURTAIN FINISH TO MATCH ADJACENT STOREFRONT. SPECIFIC WINDOW SELECTION BASED ON REGIONAL AND CLIMATE VARIATIONS.
11. DT WINDOW SHELF: INSTALL SERVICE WINDOW SHELF AT 36" AFF INSIDE AND 42" AFF OUTSIDE, AS MEASURED ABOVE THE DT SURFACE, OR AS PER REGIONAL OR SITE REQUIREMENTS.
- CANOPIES AND AWNINGS**
12. DT CANOPY: CANOPY AT DT WINDOW SHALL BE MIN 9'-6" AFF CLEAR ABOVE THE DT LANE, PREFERRED 10'-0" AFF TO ALIGN WITH VISUAL HEIGHT OF STOREFRONT CANOPY.
13. STOREFRONT: INCLUDE EXTERIOR CANOPY, AWNINGS, OR VERTICAL FAÇADE ARTICULATION AT WINDOWS TO REDUCE SOLAR HEAT GAIN AND GLARE, PREFERRED BOTTOM HEIGHT OF 9'-0" AFF TO ALIGN WITH TOP OF STOREFRONT HEADER.
14. GAS METER
15. CANOPY DOWNSPOUTS: CONNECT TO UNDERGROUND STORM DRAIN
16. ROOF SCUPPER AND OVERFLOW: CONNECT TO UNDERGROUND STORM DRAIN.
- BUILDING SIGNAGE**
17. SIREN DISK: PRIMARY SIGNAGE OPTION, CENTER SIREN ABOVE ENTRY DOORS, TYPICAL.
18. WORDMARK: SECONDARY SIGNAGE OPTION, PREFERRED USAGE OF "STARBUCKS" RATHER THAN "STARBUCKS COFFEE".
19. DRIVE THRU SIGN: LOCATE SIGN ON BUILDING TO INFORM DRIVERS WHICH DIRECTION TO TRAVEL TO DT LANE ENTRY.
20. EXTERIOR LIGHTING: PROVIDE EXTERIOR SCENES AS INDICATED, LOCATE SECURITY LIGHT AT EXTERIOR ENTRANCES, MOUNT AT 10'-0" AFF OR AS CANOPY HEIGHT PERMITS.
21. FOUR (4) WALK-UP MENU BOARDS, SECURE TO BUILDING FAÇADE.
22. ROOF ACCESS LADDER: LOCATE RETRACTABLE ROOF ACCESS LADDER IN INCONSPICUOUS LOCATION, AWAY FROM CUSTOMER VIEW, REAR OF BUILDING ADJACENT TO SERVICE DOOR PREFERRED.
23. LOCKABLE HOSE BIB
24. PROVIDE 3/4" MARINE GRADE PLYWOOD FOR FIXTURE ATTACHMENTS, TYPICAL.

**REVISIONS**

1	
2	
3	
4	
5	
6	

**LJ CONSTRUCTION**  
 Space Planning, Interior Design, Construction  
 15802 A. HALLIBURTON RD., #182  
 HACIENDA HEIGHTS, CA 91745  
 (626) 9877738 LIC. #793642  
 info@ljcon.com  
 DESIGNER/CONTRACTOR



*Hong Chuen Chao*

**ELEVATION PLAN**

**STARBUCKS**  
 541 E. WHITTIER BLVD., LA HABRA 90631

Date: 07/15/2023  
 Scale: AS SHOWN  
 Drawn: JC  
 Job:  
 Sheet

**A-5.0**

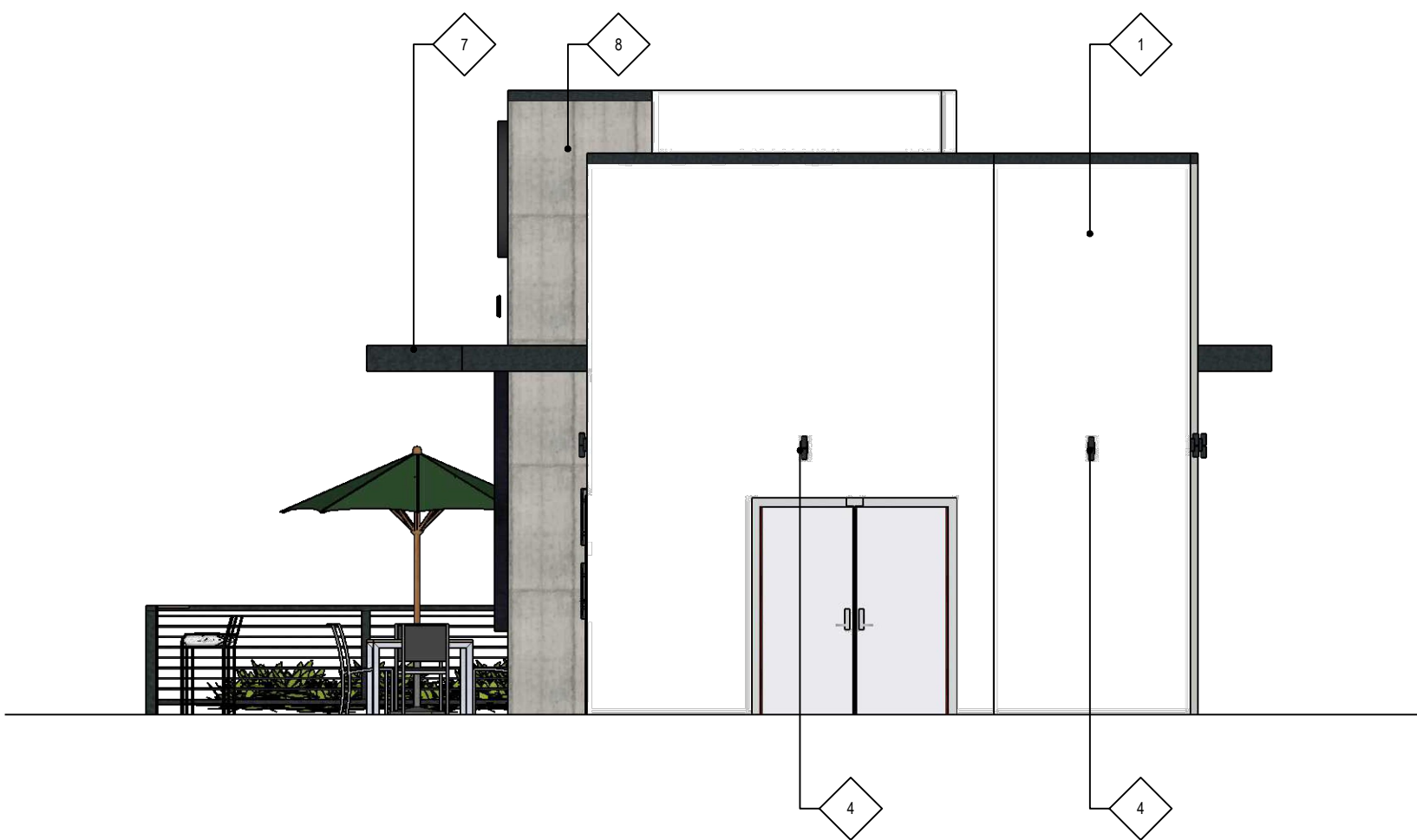

NORTH ELEVATION

SCALE: 3/16=1'-0"

3



EAST ELEVATION

SCALE: 3/16=1'-0"

1



SOUTH ELEVATION

SCALE: 3/16=1'-0"

4

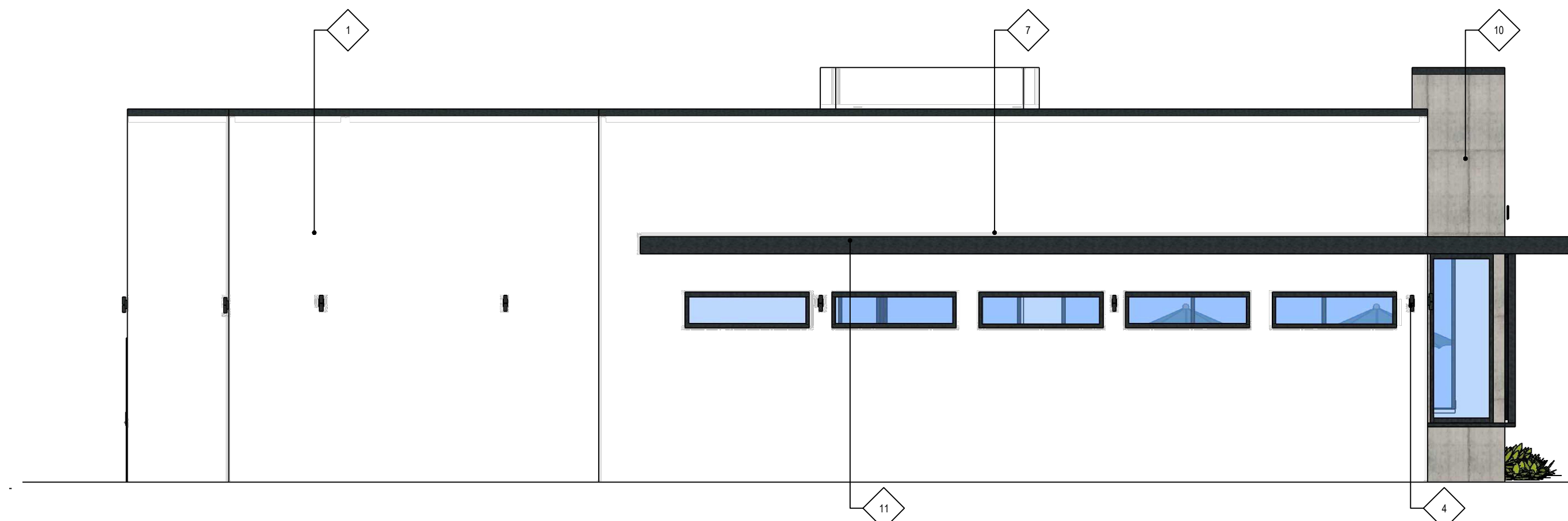

WEST ELEVATION

SCALE: 3/16=1'-0"

2



WALL TILE/CLADDING  
SANT AGOSTINO- FORM TILE  
24"x48" CEMENT



OMEGA SMOOTH STUCCO  
SANTA BARBARA  
9205 ICEBERG



NICHIHA  
COMPOSITE WOOD  
VINTAGEWOOD CEDAR



METAL COLOR  
MT 0028

FINISH SCHEDULE	
1	OMEGA COLORTEK INTEGRAL COLOR NO. 9563 SANTA BARBARA SMOOTH FINISH
2	DRIVE-THRU WINDOW
3	STOREFRONT SYSTEM
4	EXTERIOR WALL SCONCE
5	WALK-UP WINDOW
6	SOLID METAL DOOR
7	METAL CANOPY
8	OMEGA COLORTEK INTEGRAL COLOR NO. 9252 ICE CUBE SMOOTH FINISH
9	SIGNAGE UNDER SEPARATE PERMIT
10	WALL TILE SANTAGOTINO
11	COMPOSITION WOOD @UNDER SIDE OF THE CANOPY

REVISIONS
1
2
3
4
5
6

LJ CONSTRUCTION  
Space Planning, Interior Design, Construction  
15802 A HALLIBURTON RD., #182  
HACIENDA HEIGHTS, CA 91745  
TEL: 951-948-1188 LIC. #793642  
E-MAIL: info@ljconstruction.com  
DESIGNER/CONTRACTOR

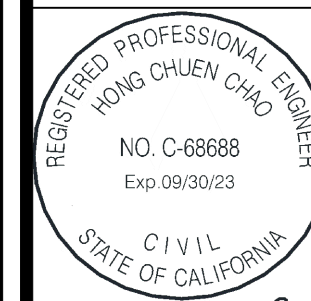

Hong Chuen Chao

COLOR ELEVATION

STARBUCKS  
541 E. WHITTIER BLVD., LA HABRA 90631

Date: 07/15/2023  
Scale: AS SHOWN  
Drawn: JC  
Job:  
Sheet  
A-6.0

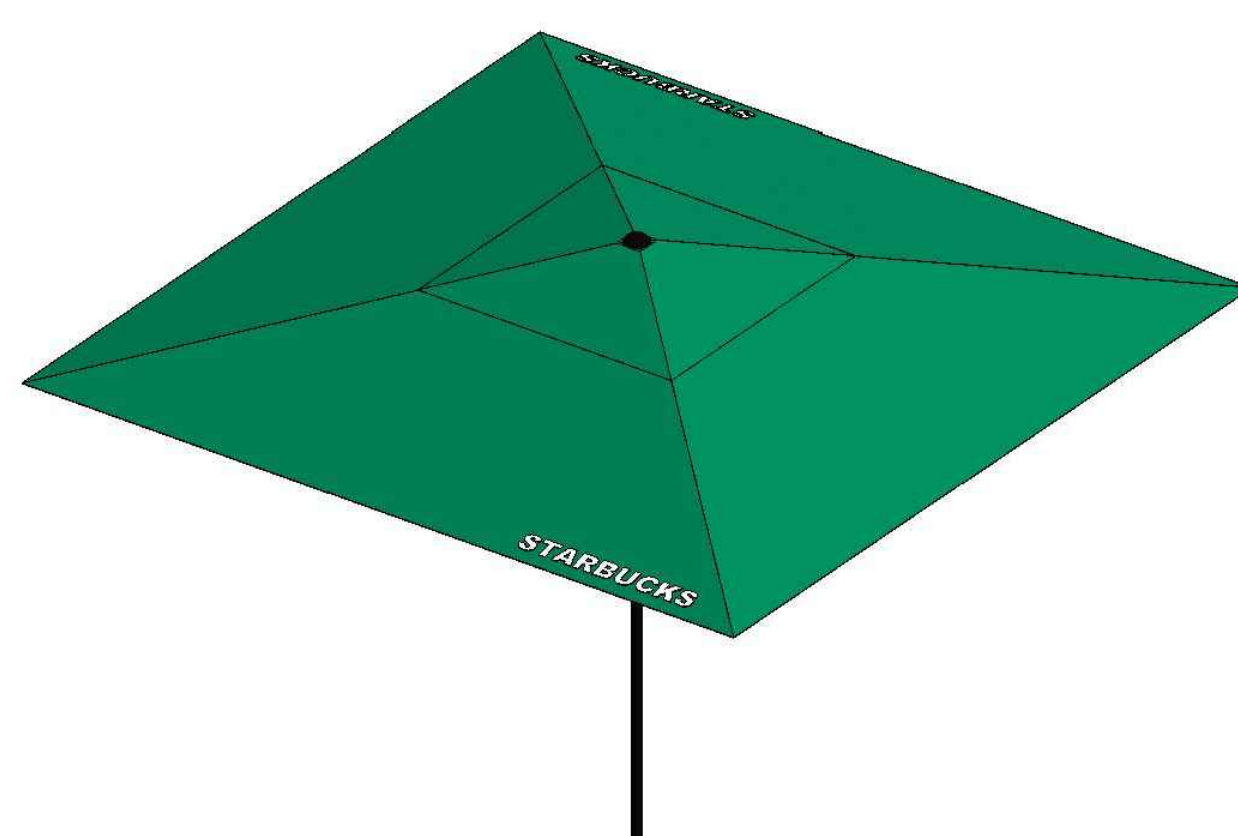

Specification 10' (3m) UMBRELLA BASE 200LBS (91Kg) (BLACK)



NO.	Description	Material
1	Cap Lock	Stainless steel 304
2	Spacer	Space 303 Stainless Steel
3	Driving Bolt/ Nut	A307 F304
4	Lock Nut/ Washer	Stainless steel 18-8
5	Spacer 1/2" x 1/2"	Stainless steel 18-8
6	Spacer 1/2" x 1/2"	Stainless steel 18-8
7	Spacer 1/2" x 1/2"	Stainless steel 18-8
8	Aluminum Plate	Aluminum 3004 (3003plus) 28 GA
9	Scratch Plate	Sheet with Black Powder Coat
10	Anti-rattle Stop 21kg	Concrete Block
11	Rubber Gasket	Rubber

global headquarters  
2000 Ave of the Americas  
New York, NY 10013 USA  
Tel: 212 512 2000  
Fax: 212 512 2001  
www.starbucks.com

18714

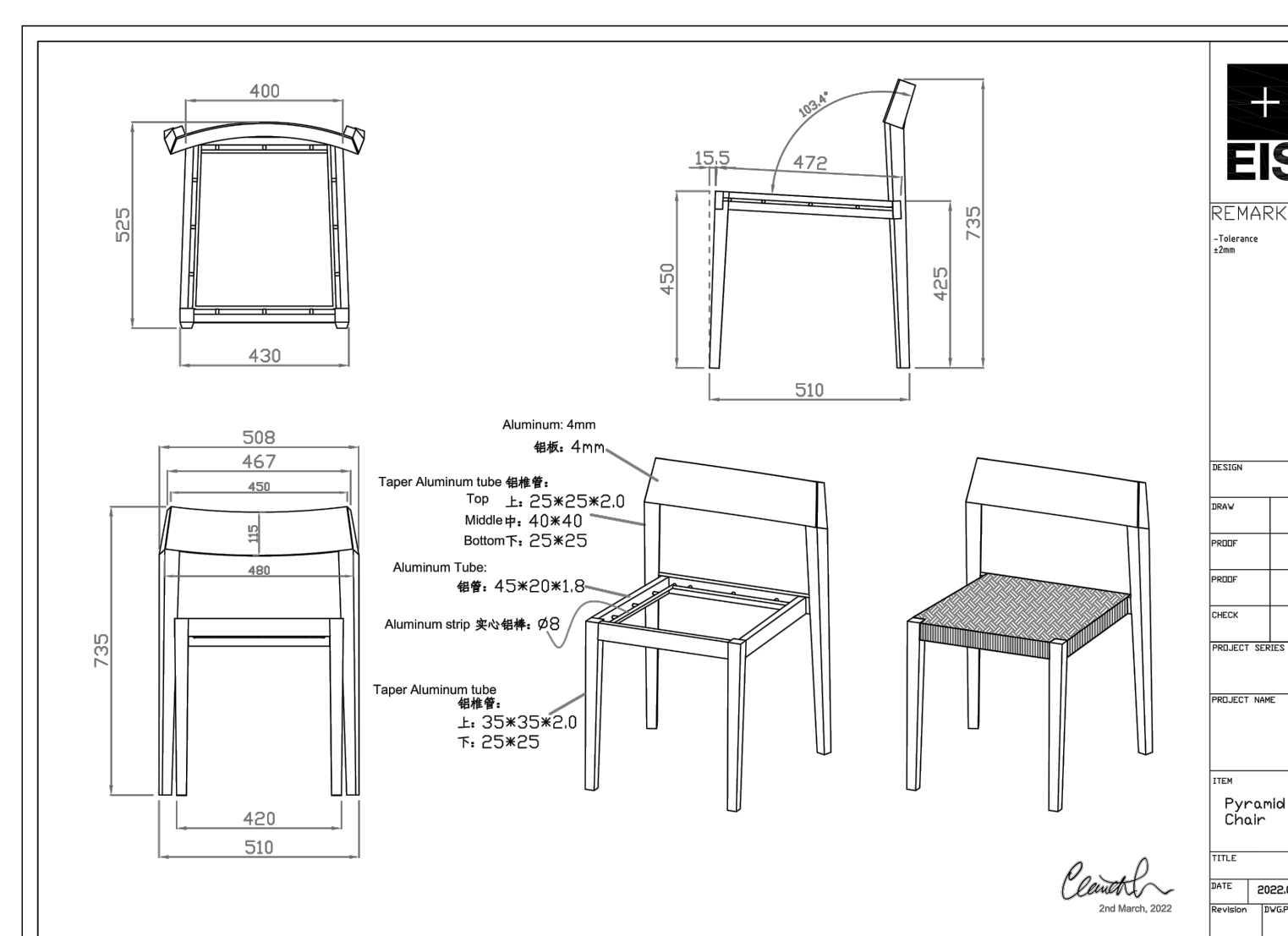
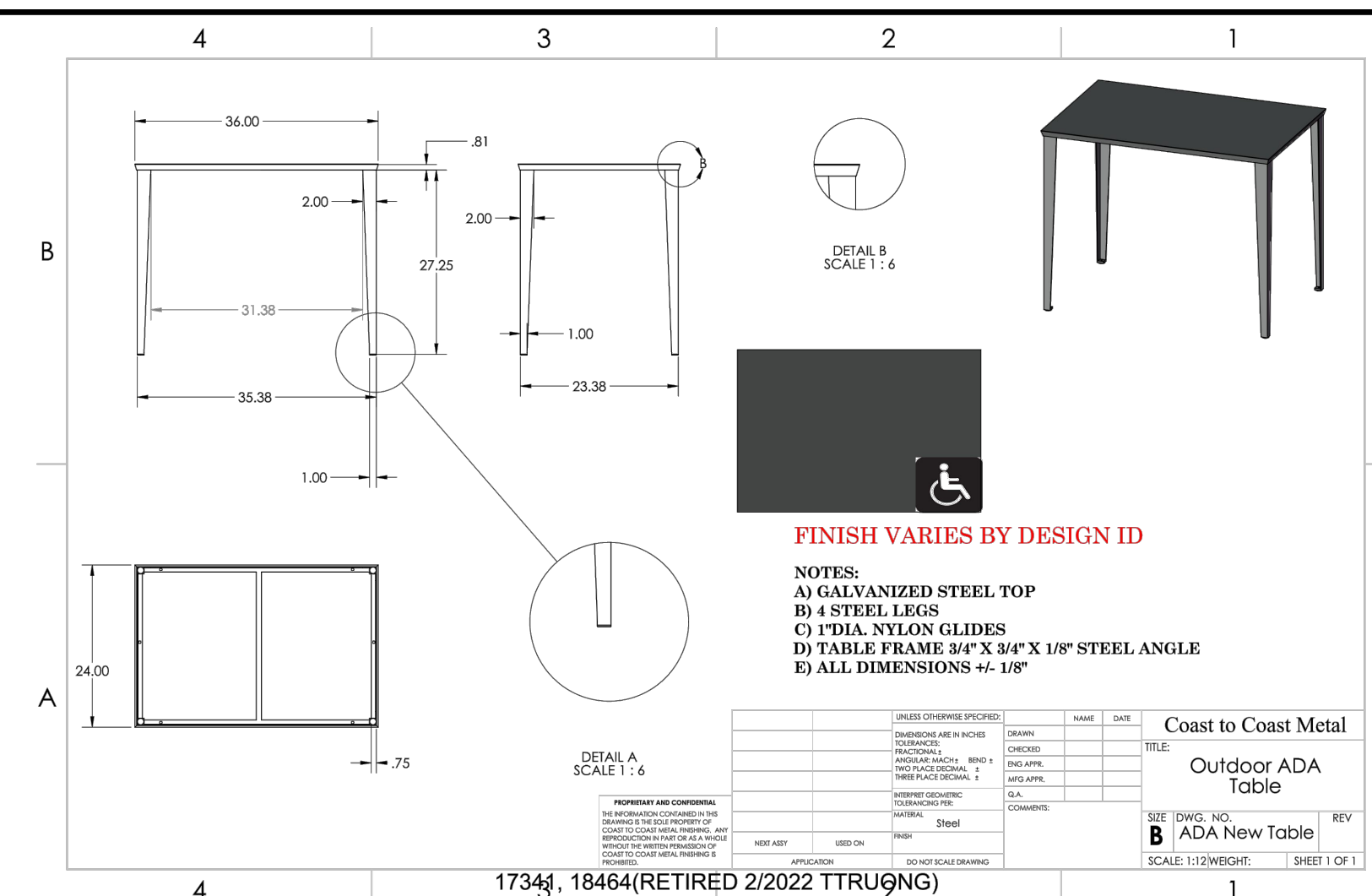

Starbucks 10' square with logo

The Starbucks 10' square parasol is engineered with a marine satin anodized finish and includes a auto lock lift auto-stop with stainless steel security pin. Built to withstand winds up to 20mph. This parasol features 100% recyclable parts.

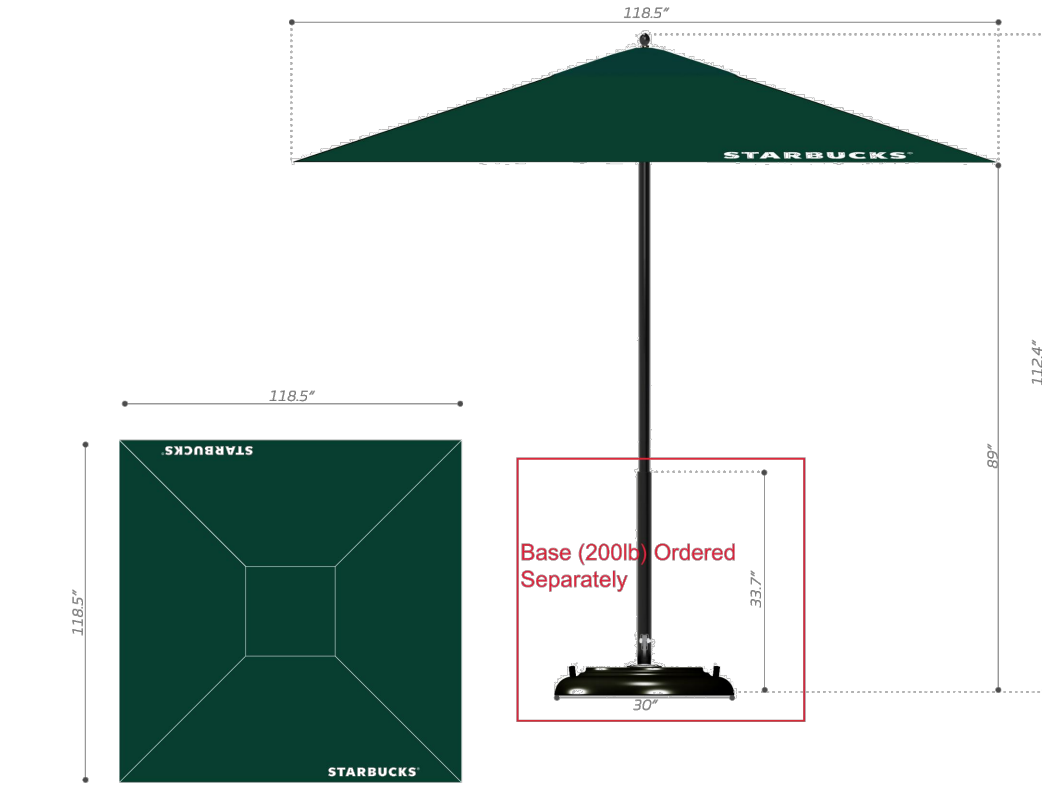

COLOR	SIZE	CANOPY
Hemlock Tweed	10'	WITH LOGO
charcoal grey	10'	WITH LOGO
Black	10'	WITH LOGO

FINISH VARIES BY DESIGN ID:  
20076 GREEN  
20078 BLACK  
20077 GREY

1 TUUCI 1000000 200519

RATANA CONTRACT

Pyramid Café Chair – Final Drawings

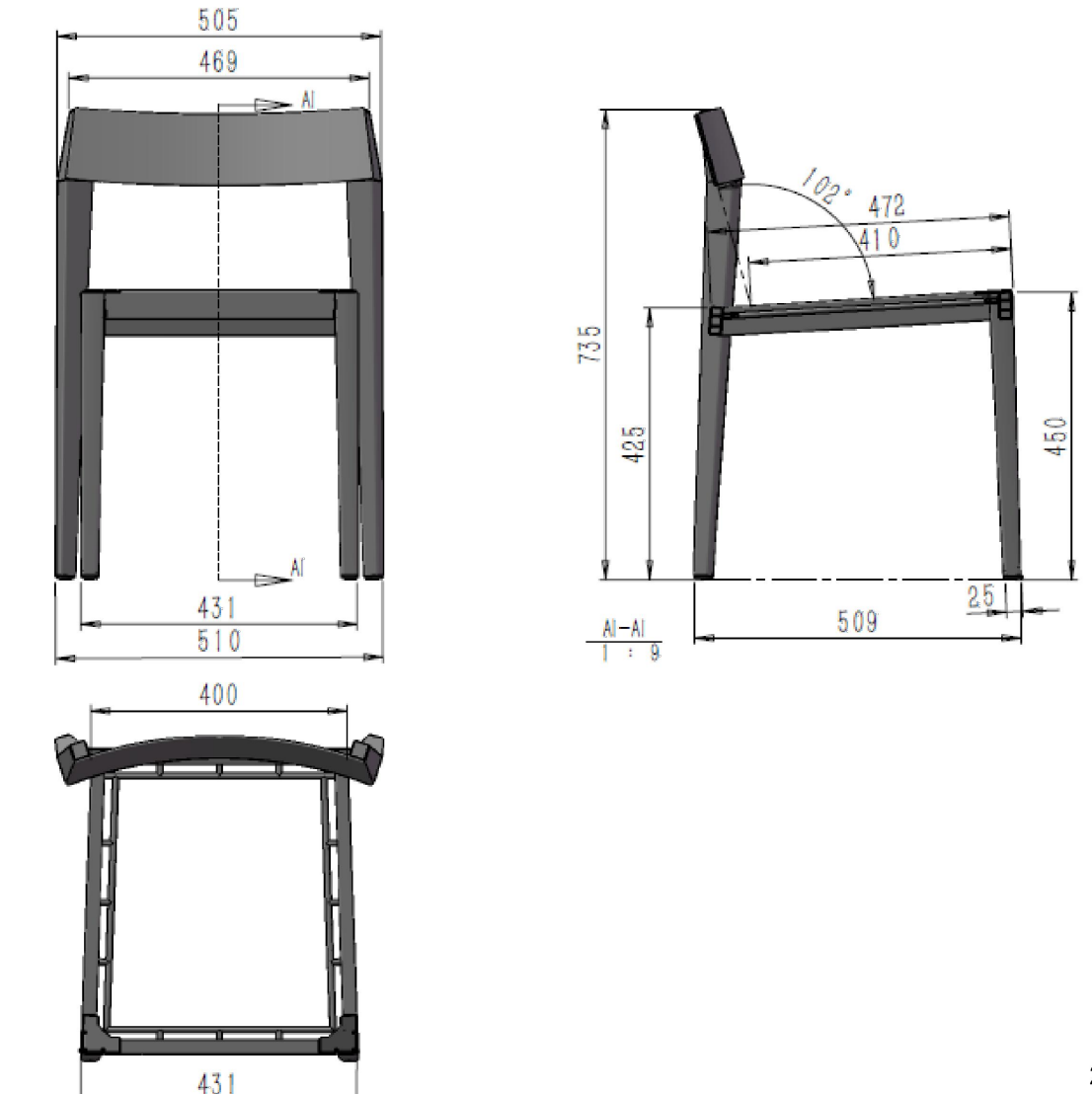

FINISH VARIES BY DESIGN ID  
17852, 17853

Page 1 of 2

2016 November 10th

REVISIONS

1	
2	
3	
4	
5	
6	

LJ CONSTRUCTION  
Space Planning, Interior Design, Construction  
15802 A HALLIBURTON RD., #182  
HACIENDA HEIGHTS, CA 91745  
(626) 967 7738 LIC. #798942  
lucy@ljconstruction.com  
DESIGNER/CONTRACTOR



Hong Chuen Chao

PATIO FURNITURE

STARBUCKS  
541 E. WHITTIER BLVD., LA HABRA 90631

Date: 07/15/2023  
Scale: AS SHOWN  
Drawn: JC  
Job:

Sheet  
A-6.1

PATIO FURNITURE DETAIL

SCALE: N.T.S.

1



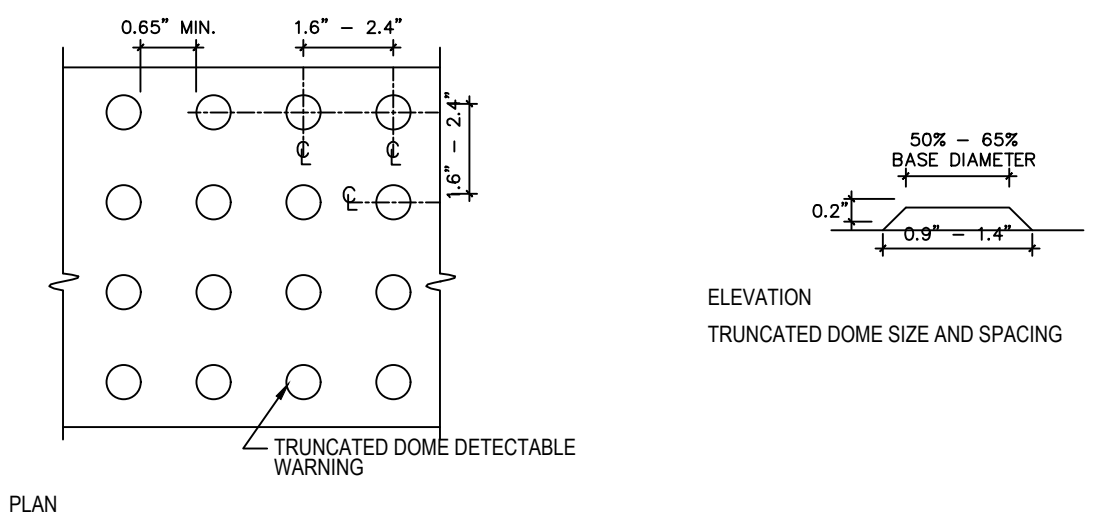
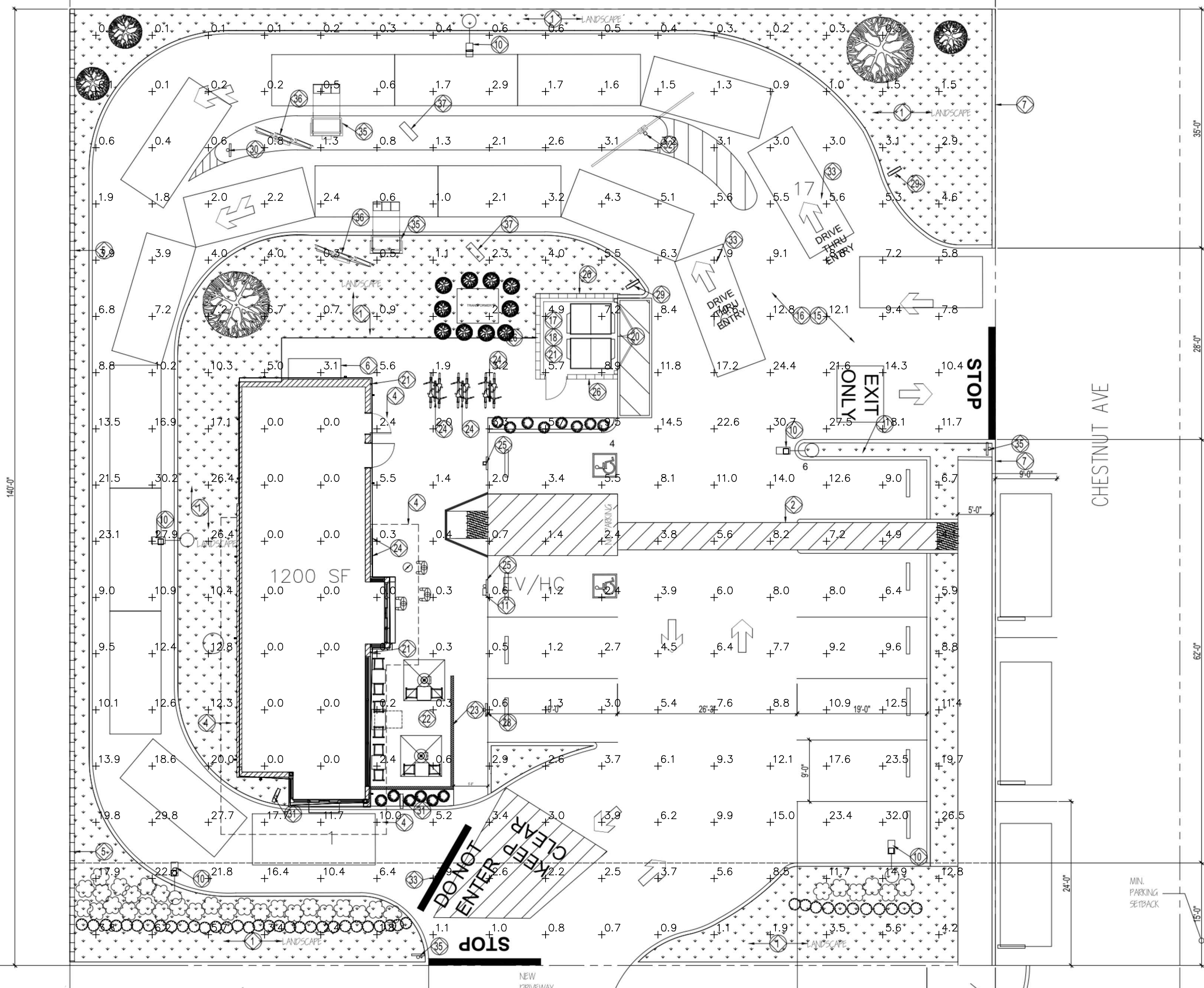

**NOTES:**  
 PROVIDE DETECTABLE WARNING DETAILS SHOWING COMPLIANCE WITH THE FOLLOWING:  
 a. TURNATED DOMES IN A DETECTABLE WARNING SURFACE SHALL HAVE A BASE DIAMETER OF 0.9 TO 0.92 INCHES, A TOP DIAMETER OF 0.45 TO 0.47 INCHES, AND A HEIGHT OF 0.18 TO 0.22 INCHES. §11B-705.1.1, FIGURE 11B-705.1.  
 b. TURNATED DOMES PLACED IN A GRID PATTERN IN A DETECTABLE WARNING SURFACE SHALL HAVE A CENTER-TO-CENTER SPACING OF 2.3 TO 2.4 INCHES, AND A MINIMUM BASE-TO-BASE SPACING OF 0.65 INCHES, MEASURED BETWEEN THE MOST ADJACENT DOMES ON A SQUARE GRID. §11B-705.1.1.2, FIGURE 11B-705.1.  
 c. TURNATED DOMES PLACED IN A RADIAL PATTERN IN A DETECTABLE WARNING SURFACE SHALL HAVE A CENTER-TO-CENTER SPACING OF 1.6 TO 2.4 INCHES, AND MINIMUM BASE-TO-BASE SPACING OF 0.65 INCHES, MEASURED BETWEEN THE MOST ADJACENT DOMES ON A SQUARE GRID. §11B-705.1.1.2, FIGURE 11B-705.1.  
 d. DETECTABLE WARNING SURFACES SHALL VISUALLY CONTRAST LIGHT-ON-DARK OR DARK-ON-LIGHT WITH ADJACENT WALKING SURFACES OR BE SEPARATED FROM ADJACENT SURFACE BY A 1 INCH WIDE BLACK STRIP. MATERIAL USED TO PROVIDE CONTRAST SHALL BE AN INTEGRAL PART OF THE SURFACE. §11B-705.1.1.3  
 e. DETECTABLE WARNING SURFACES SHALL DIFFER FROM ADJOINING SURFACES IN RESILIENCY OR SOUND-ON-CANE CONTRACT EXCEPT AT CURB RAMPS, ISLANDS OR CUT-THROUGH MEDIANS. §11B-705.1.1.4

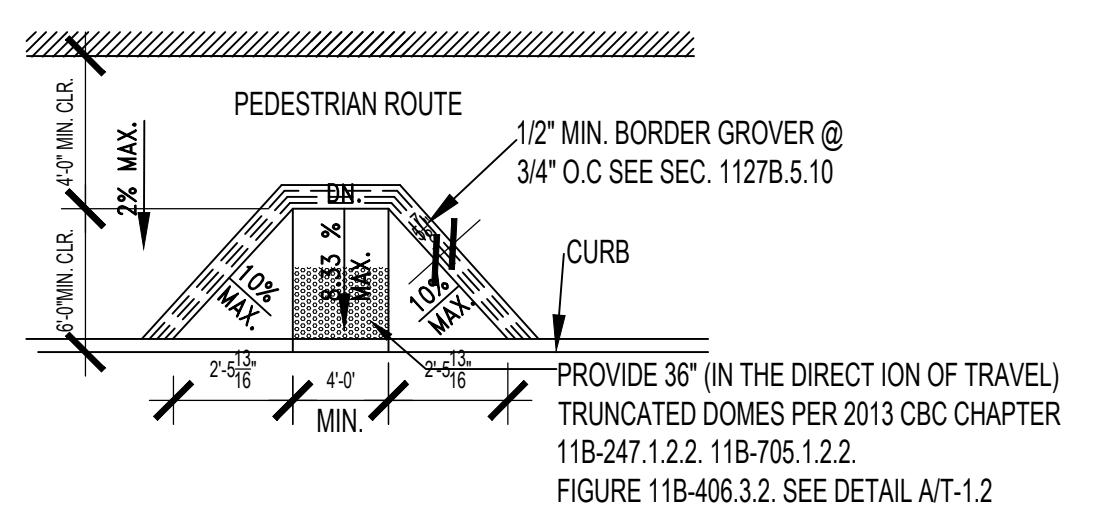

**CURB RAMP** N.T.S. 1

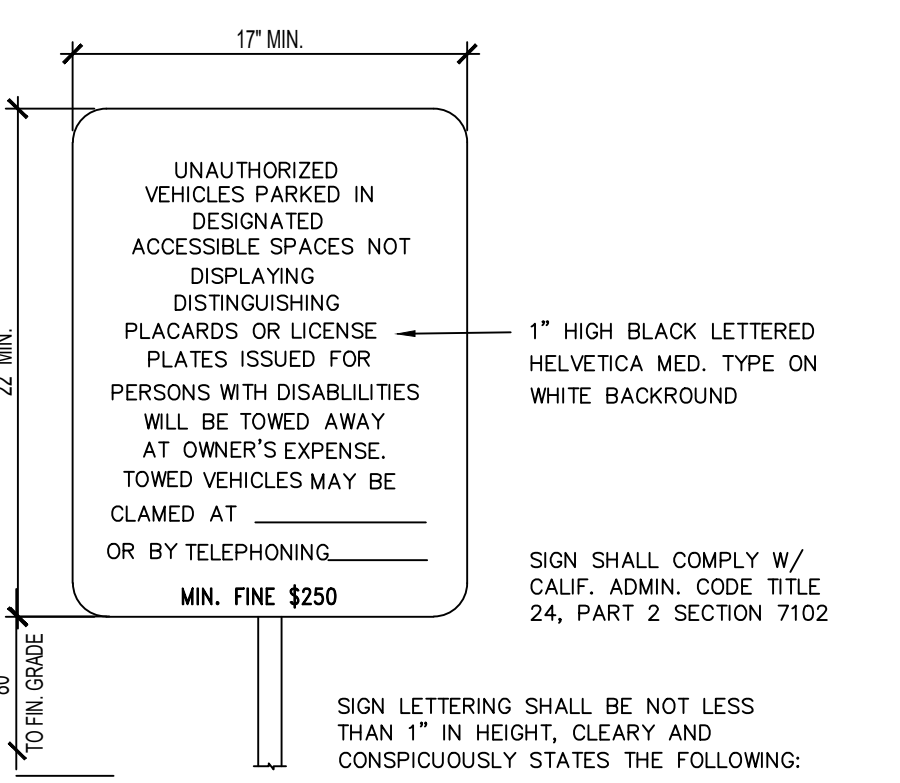

**ACCESSIBLE PARKING NOTICE** N.T.S. 2

**TRUNCATED DOME DETAIL** N.T.S. 5

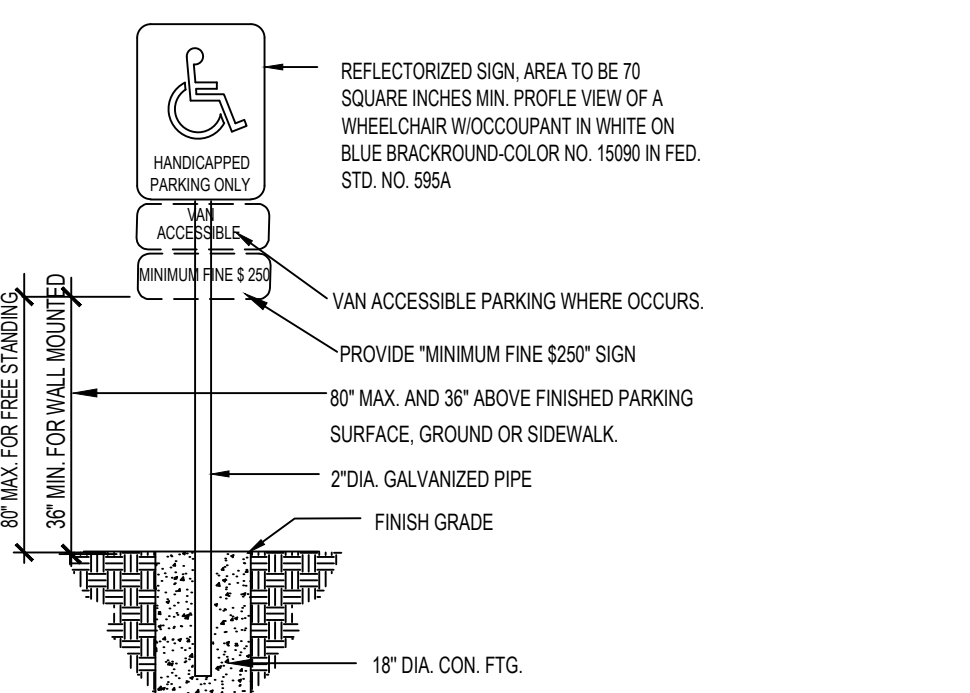
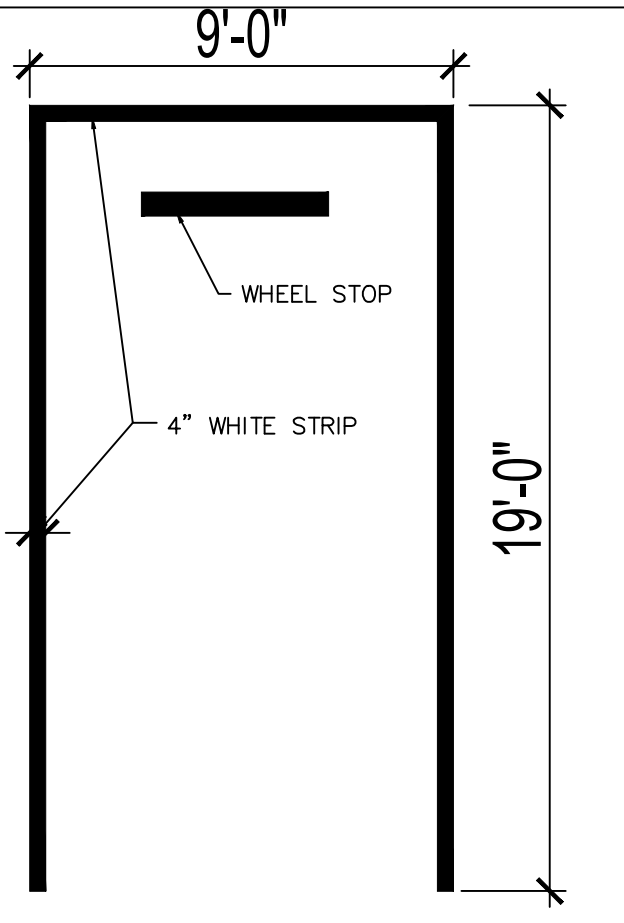

**STRIPING STANDARD** N.T.S. 6

**ACCESSIBLE PARKING SIGN** N.T.S. 3

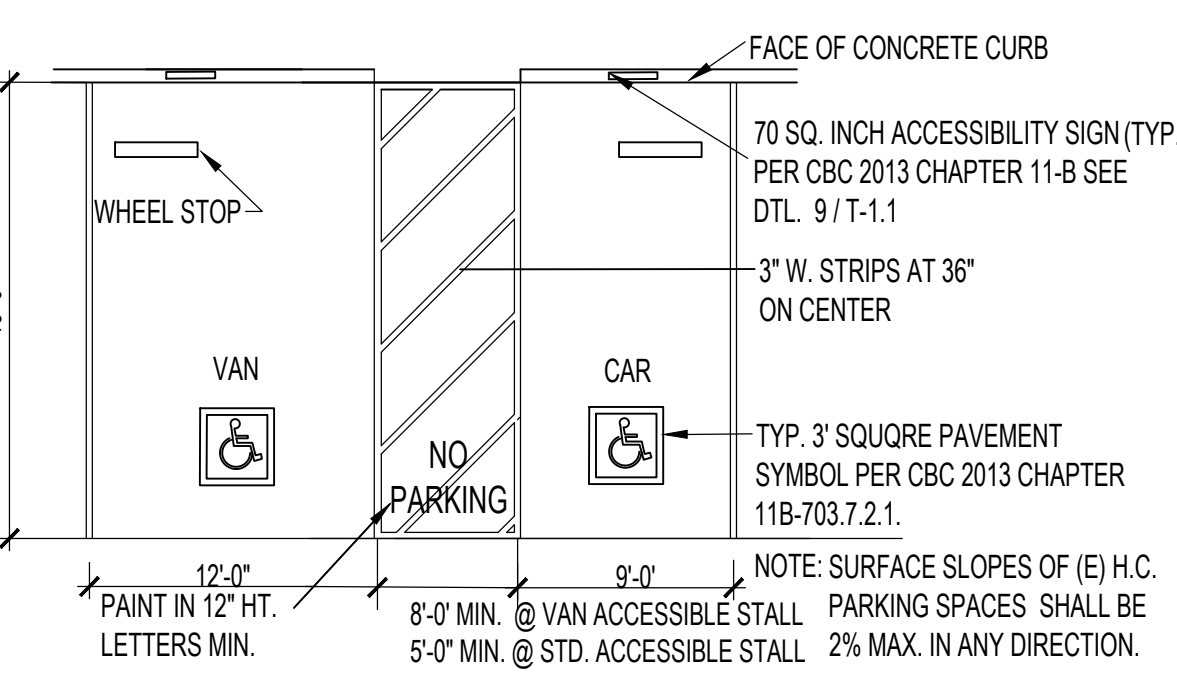
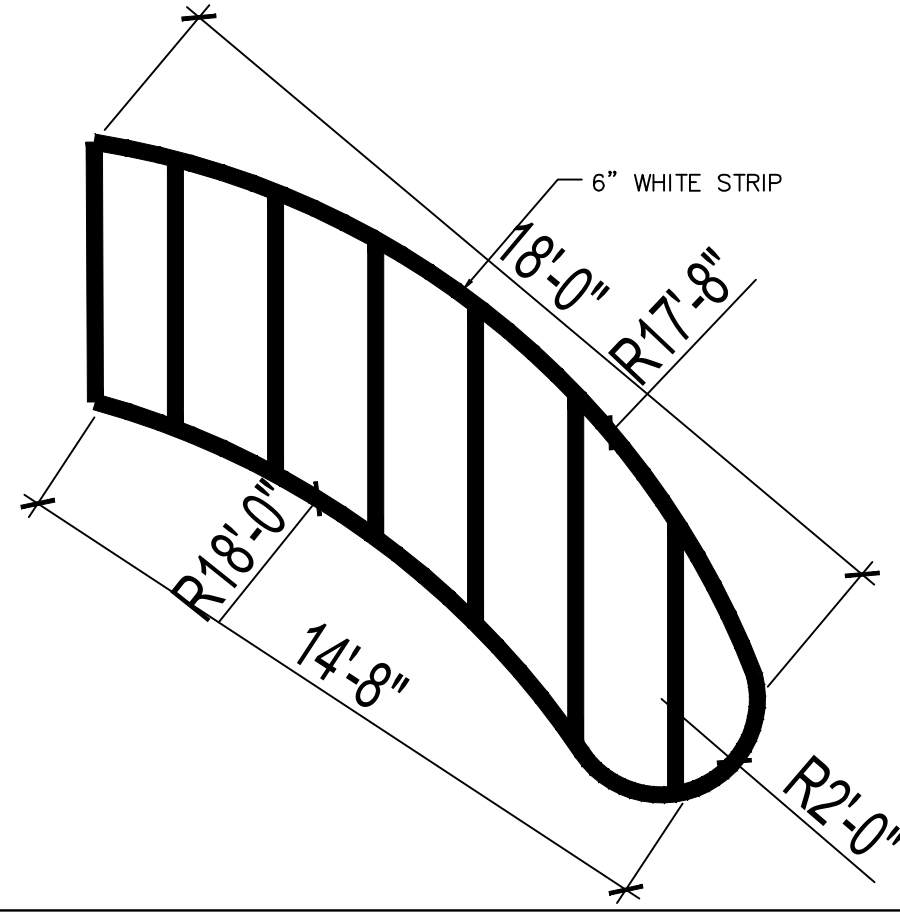

**STRIPING STANDARD** N.T.S. 7

**ACCESSIBLE PARKING** N.T.S. 4

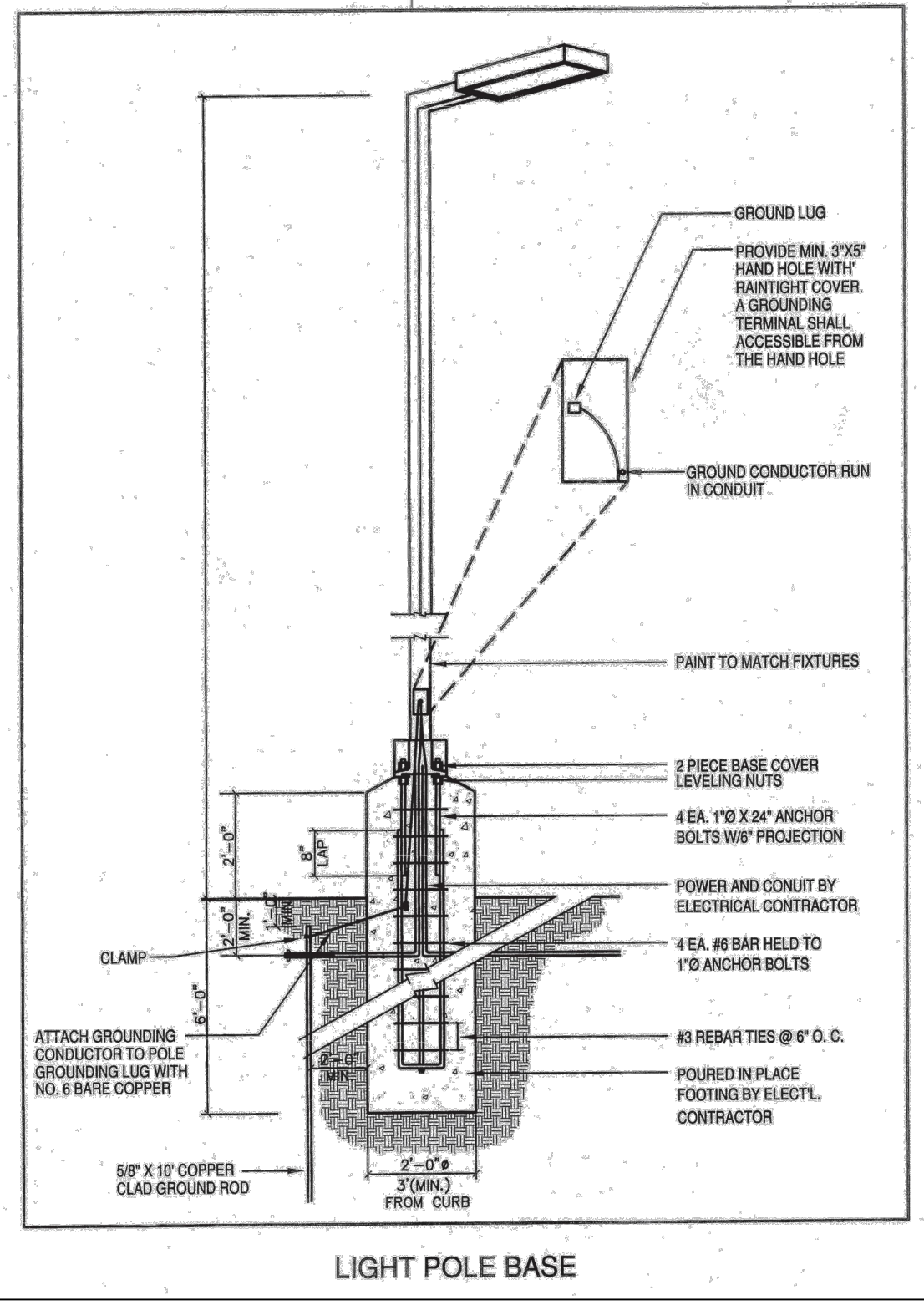

**Ordering Information**

**Accessories**

**External Shields**

**House Side Shield**    **External Glass Shield**    **External 360 Full Visor**

**Pole/Mounting Information**

**ROUND TENSION POLE - POLE TOP SLIPSTIFFERS**

**Drill/Slot Location by Configuration Type**

**RSX1 - Luminaire EPA**

**RSX STANDARD ARM & ADJUSTABLE ARM**

**LITHONIA LIGHTING**

**RSX1 LED Area Luminaire**

**Specifications**

**Introduction**

**Ordering Information**

**EXAMPLE: RSX1 LED P4 40x R3 MVOLT SPA DDBXD**

**Shipping Standard**

**LITHONIA LIGHTING**

**LIGHTING DETAIL**

**SCALE: NTS** 8

**REVISIONS**

**DETAIL**

**STARBUCKS**

541 E. WHITTIER BLVD., LA HABRA 90631

Date: 07/15/2023  
 Scale: AS SHOWN  
 Drawn: JC  
 Job:  
 Sheet: A-8.0

**L.J. CONSTRUCTION**  
 Space Planning, Interior Design, Construction  
 15802 A HALLIBURTON RD., #182  
 HACIENDA HEIGHTS, CA 91745  
 (626) 967-7738 LIC. #93642  
 @ljcon.com  
 DESIGNER/CONTRACTOR

**REGISTERED PROFESSIONAL ENGINEER**  
 HONG CHUEN CHAO  
 NO. C-68888  
 Exp. 09/30/23  
 CIVIL  
 STATE OF CALIFORNIA  
 HongChuenChao

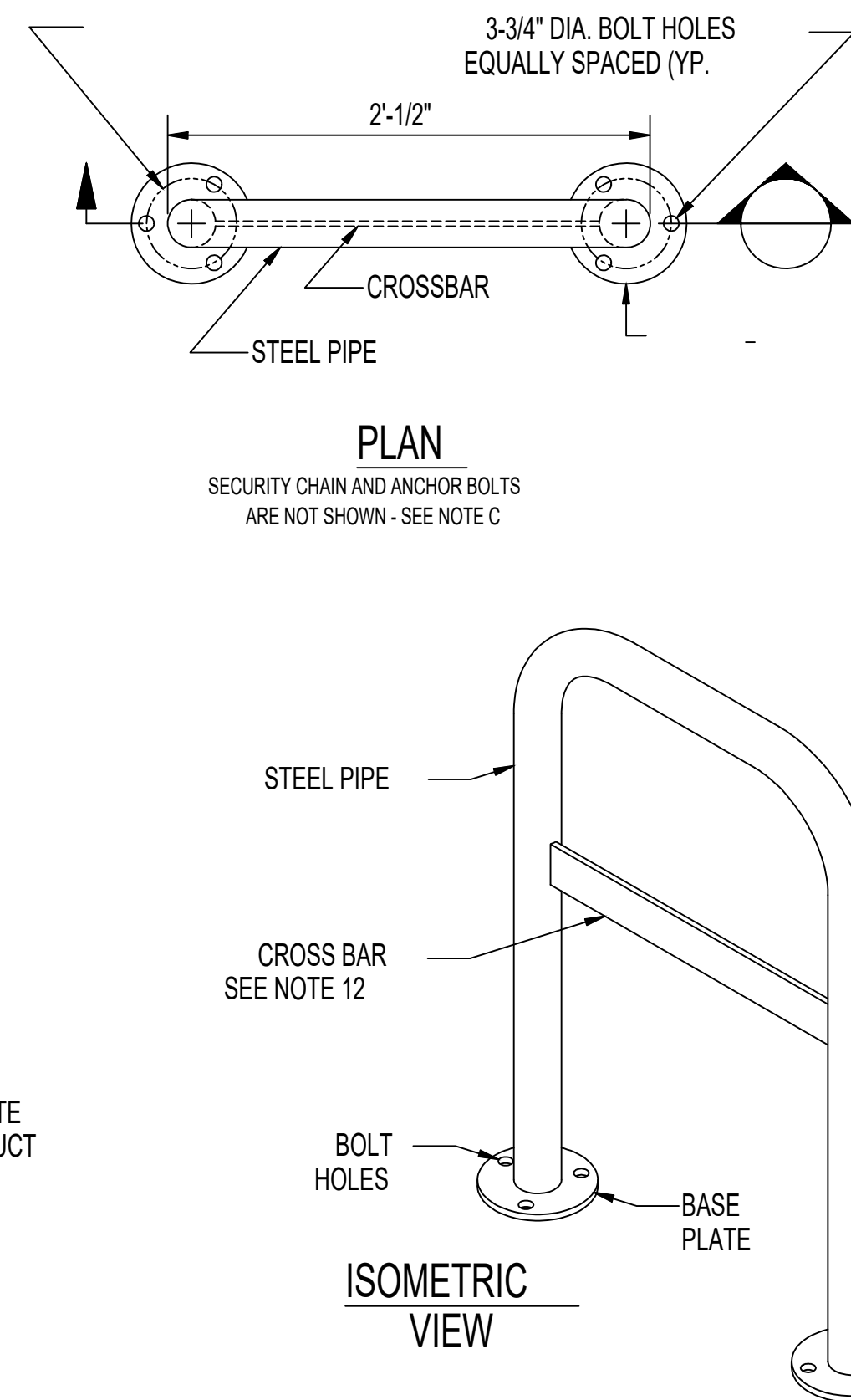
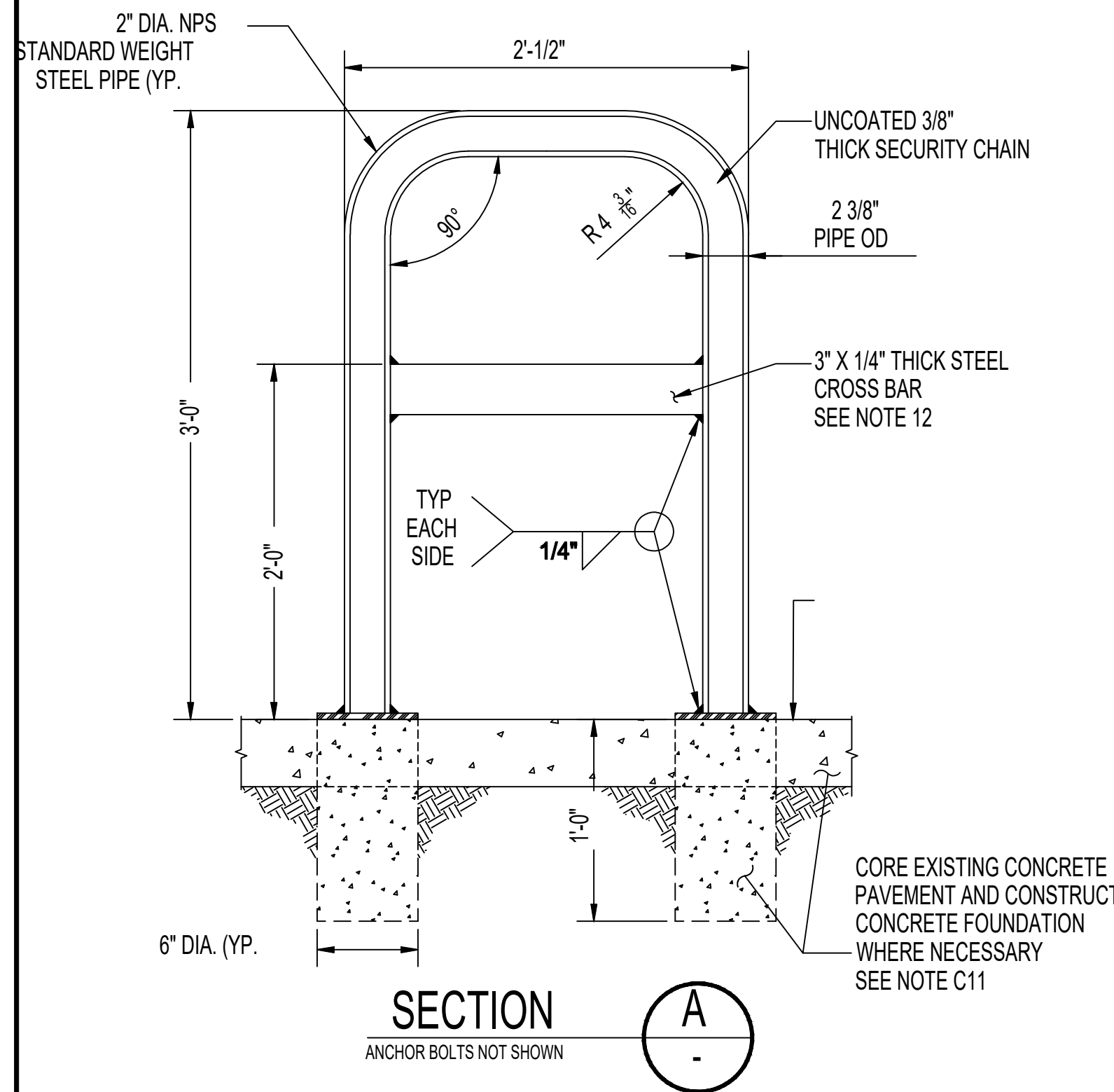

**SPECIFICATIONS**

- Notes:
- 4" FPT inlet/outlet with 4" plain end adapters, single inlet and triple outlet.
  - Unit weight - w/ cast iron covers: 190 lbs. (For wet weight add 1,043 lbs.)
  - Maximum operating temperature: 150° F continuous
  - Capacities - Liquid: 125 gal.  
Grease: 861 lbs. (118 gal.) @75 GPM  
Solids: 31 gal.
  - For gravity drainage applications only.
  - Do not use for pressure applications.
  - Cover placement allows full access to tank for proper maintenance.
  - Vent not required unless per local code.
  - Engineered inlet and outlet diffusers with inspection ports are removable to inspect / clean piping.
  - Integral air relief / Anti-siphon / Sampling access.
  - Adjustable cover adapter provides up to 4" of additional height.
  - Designed for below-grade, above-grade, indoor and outdoor installations.
  - Safety Star® access restrictor built into cover adapter, prevents accidental entry to tank (450 lb rating).

**ENGINEER SPECIFICATION GUIDE**

Schier Great Basin™ grease interceptor model # GB-75 shall be lifetime guaranteed and made in USA of seamless, rotationally-molded polyethylene with minimum 3/8" uniform wall thickness. Interceptor shall be furnished for above or below-grade installation with adjustable cover adapter, Safety Star® access restrictor built into each cover adapter, and three outlet options. Interceptor shall be certified to ASME A112.14.3 (Type D) and CSA B481.1. Interceptor flow rate shall be 75 GPM. Interceptor grease capacity shall be 861 lbs. Cover shall provide water/gas-tight seal and have minimum 16,000 lbs. load capacity.

**CERTIFIED PERFORMANCE**

Great Basin™ hydromechanical grease interceptors are third party performance-tested and listed by IAPMO to ASME #A112.14.3 and CSA B481.1 grease interceptor standards and greatly exceed requirements for grease separation and storage. They are compliant to the Uniform Plumbing Code and the International Plumbing Code.

Type D certification does not require a flow control

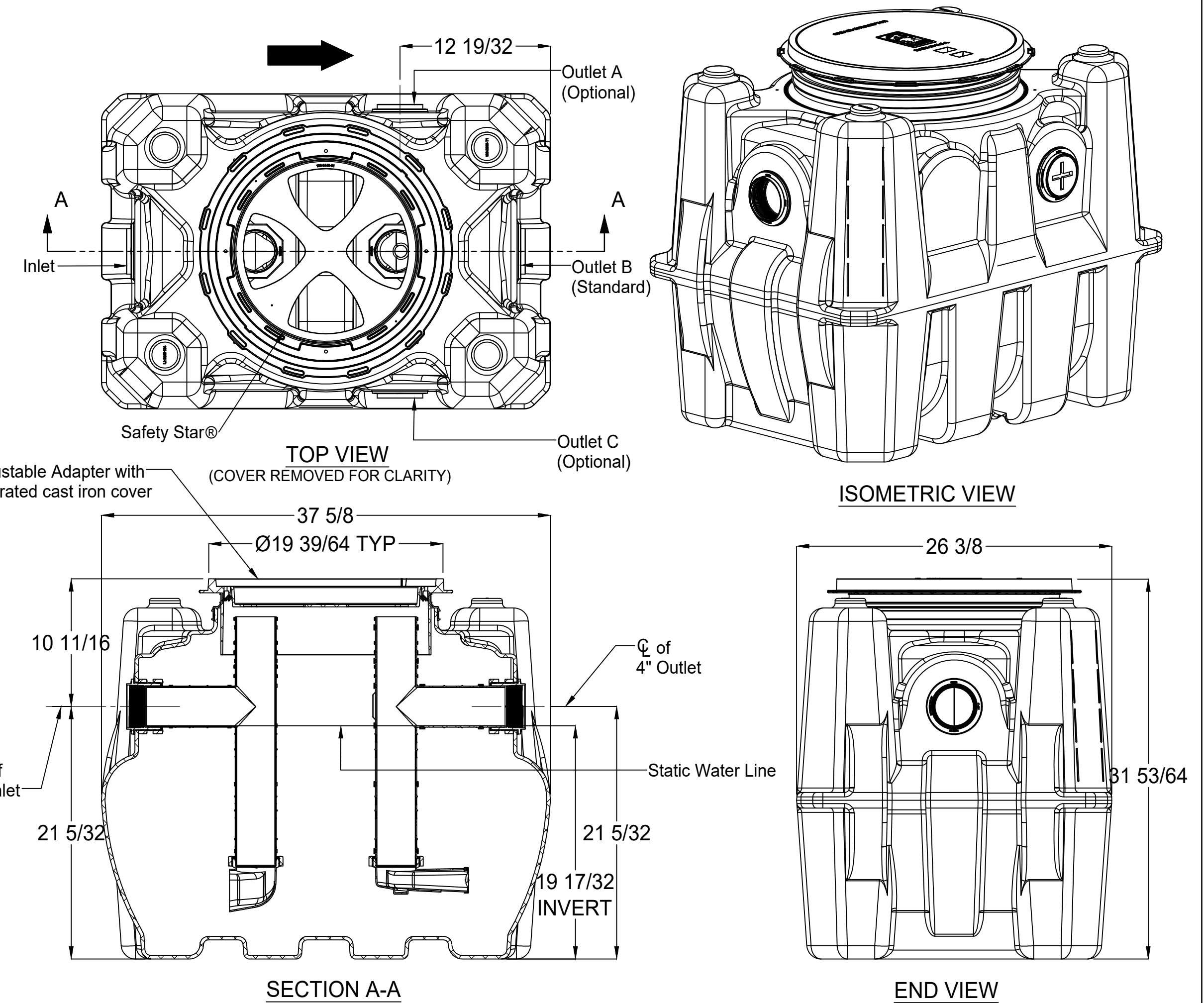

<b>MODEL NUMBER:</b> <b>GB-75</b>	<b>PART NUMBER:</b> 4045-007-02		<p>6455 Woodland Dr Shawnee, KS 66218 Tel: 913-951-3300 Fax: 913-951-3399 schierproducts.com</p>
<b>DESCRIPTION:</b> GB-75 GREASE INTERCEPTOR 75 GPM, 4" INLET/OUTLET, H-20 RATED CAST IRON COVER	<b>DWG BY:</b> C. BUSENITZ <b>DATE:</b> 4/14/2022 <b>REV:</b> - <b>ECO:</b> -		

REVISIONS

1	
2	
3	
4	
5	
6	

LJ CONSTRUCTION  
Space Planning, Interior Design, Construction  
15802 A HALLIBURTON RD., #182  
HACIENDA HEIGHTS, CA 91745  
(626) 9677738 LIC. #798942  
luciano@luciano.com  
DESIGNER/CONTRACTOR

REGISTERED PROFESSIONAL ENGINEER  
HONG CHUEN CHAO  
NO. C-68888  
Exp. 09/30/23  
CIVIL  
STATE OF CALIFORNIA  
HongChuenChao

GREASE INTERCEPTOR

STARBUCKS  
541 E. WHITTIER BLVD., LA HABRA 90631

Date: 07/15/2023  
Scale: AS SHOWN  
Drawn: JC  
Job:  
Sheet

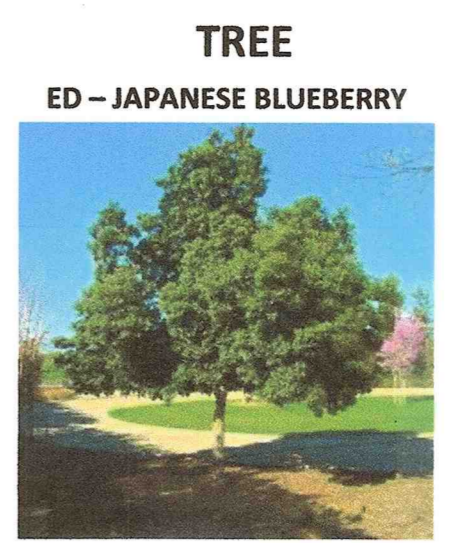
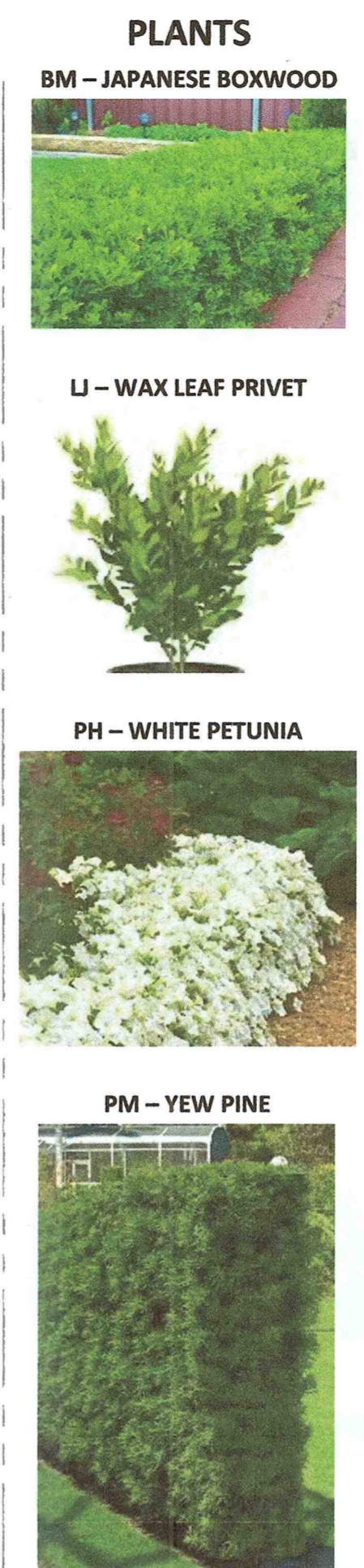
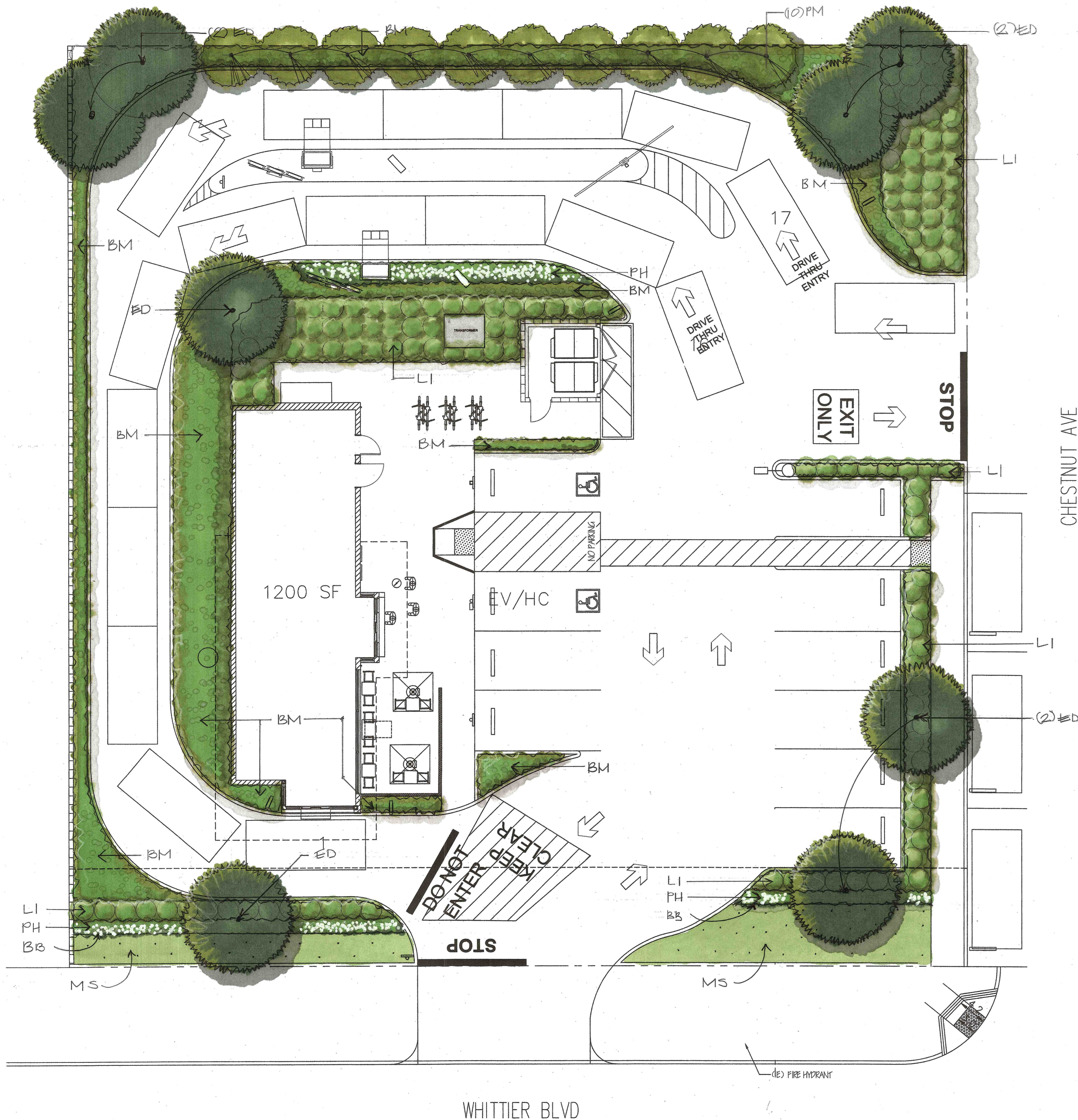

**Planting Notes**

The backfill mix for use around the root ball of all trees and shrubs shall consist of the following formula:  
 2/3 native rock free soil 1/3 organic amendment of wood mulch compost  
 1 lb/cu. yd. of backfill mix 12-12-12 commercial fertilizer Agriform or eq. time released fertilizing tablets.  
 Agriform, 21 gram fertilizer tablets (20-10-5) in quantities recommended by the manufacturer.  
 Place tablets at half the depth of the root ball.  
 Recommended thirty (30) days after installation all areas shall be fertilized with Best Fertilizer 16-16-8 or approved equal, applied at the rate of five pounds per 1000 square feet (by Owner's maintenance service)  
 Incorporate wood mulch compost at least four (4) cubic yards per 1,000 square feet to a depth of (6) inches into all landscape areas.  
 All exposed soil planter areas to be covered with 3" of shredded wood shavings or bark mulch

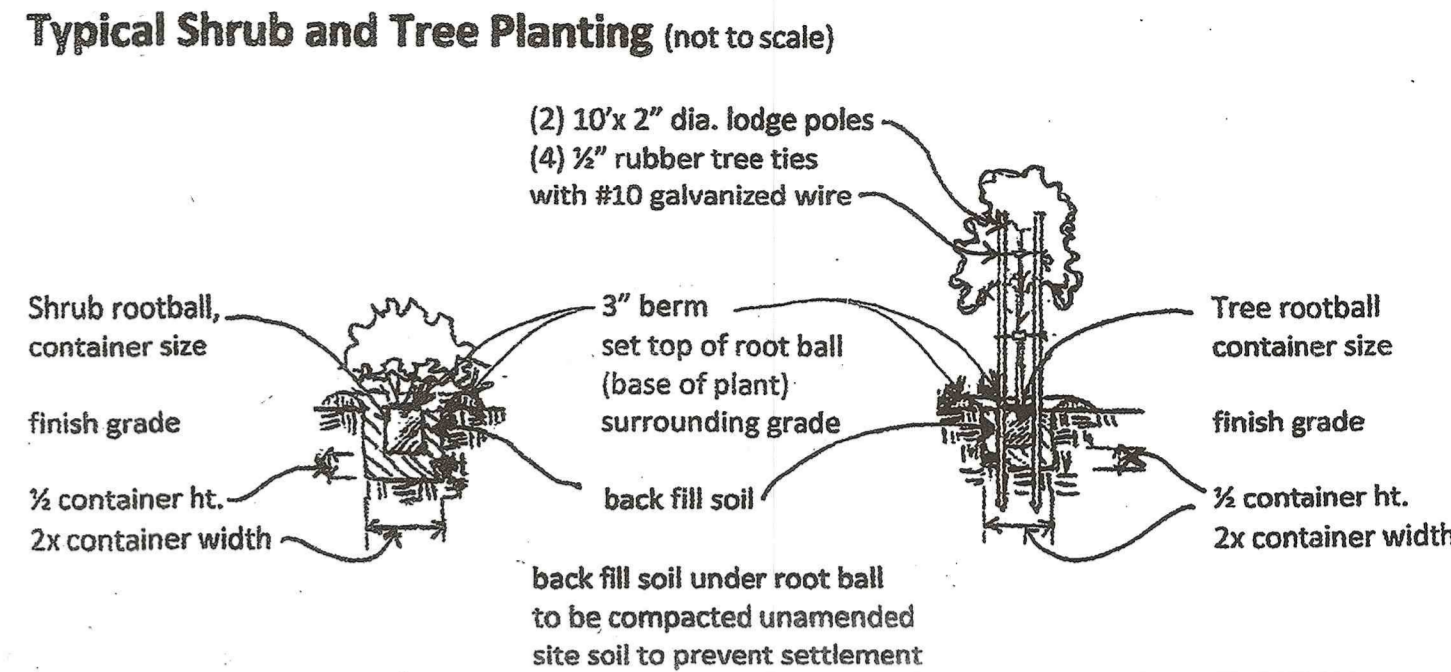

**Planting Legend**

**Shrubs**

Sym	Size	Qty	Botanical name	Common name	Variety/Remarks	Spacing
BM	1-gal	480	Buxus myriophylla	Japanese Boxwood	'Japonica'	24" o.c.
LI	5-gal	146	Ligustrum j.	wax leaf privet	'Texanum'	36" o.c.
PH	4"-pots	130	Petunia x hybrid	white petunia	'ColorRush'	18" o.c.
PM	15-gal	10	Podocarpus macrophyllus	Yew Pine	6-7 feet tall	9' o.c.

**Trees**

Sym	Size	Qty	Botanical name	Common name	Variety/Remarks
ED	15-gal	8	Elaeagnus decipens	Japanese Blueberry	tree form

**Miscellaneous**

Sym description  
 BB installed w/ plastic stakes and plated screws 3' o.c.  
 MS hybrid fescue sod lawn

**Irrigation Notes**

Automated irrigation system including multi-station, multi-program irrigation controller with weather sensing capabilities shall be installed for all proposed landscape areas.  
 All proposed landscaped planter areas shall be irrigated with surface drip irrigation lines covered mulch.  
 All turf areas shall be irrigated with 4" pop-up rotor-type irrigation heads.  
 Every 30 days irrigation contractor shall flush all drip lines and adjust all sprinkler heads and valves for optimum coverage with minimum over spray onto walks, streets, etc. After 90 days irrigation contractor should adjust irrigation system after planting material has established rooting system and seasonally adjusting run irrigation times as needed to minimize water waste. Irrigation system components shall be repaired and replaced all items damaged as needed.

**CONCEPTUAL LANDSCAPE PLAN**  
**STARBUCKS**  
 541 E WHITTIER BLVD  
 LA HABRA, CA 90631

**MANUEL GARCIA**  
 LANDSCAPE ARCHITECT  
 228 E. CAMDEN ST. GLENORA, CA. 91740  
 ST. LIC. #3929  
 CELL (626)665-5002  
 MG.LANDARCH@GMAIL.COM

December 5, 2023
Revisions performed by : DATE
MG : 2-16-24
:
:
:
:
Scale 1/8"=1'-0"
Sheet ___ of ___
L-1

NOTE: ALL GROUND SIGN ARROWS WILL BE ORIENTED TO MATCH THE FLOW OF TRAFFIC AND ILLUMINATED



2



4



8



6



7

## KEY NOTES

- 1 INSTALL DIRECTIONAL ARROWS TO BE PAINTED ON PAVEMENT, LEADING FROM WHITTIER BLVD.
- 2 INSTALL "DRIVE THRU" DIRECTIONAL GROUND SIGN WITH SIREN LOGO
- 3 INSTALL "EXIT ONLY" AND HATCH PATTERN TO BE PAINTED ON PAVEMENT, TO DISCOURAGE DRIVE-THRU CUSTOMERS ENTERING FROM CHESTNUT AVE.
- 4 INSTALL "EXIT ONLY" DIRECTIONAL GROUND SIGN WITH BLANK BACK
- 5 STAFF TO MONITOR QUEUE/UTILIZE CONES DISCOURAGING DT CUSTOMERS ENTERING FROM CHESTNUT AVE.. DURING HIGH PEAK CUSTOMER TRAFFIC
- 6 INSTALL "CAUTION VEHICLE CROSSING" SIGN AT CROSSWALK.
- 7 INSTALL "PEDESTRIAN CROSSING AHEAD" SIGN.
- 8 INSTALL "THANK YOU/EXIT ONLY" DIRECTIONAL GROUND SIGN AT DT EXIT

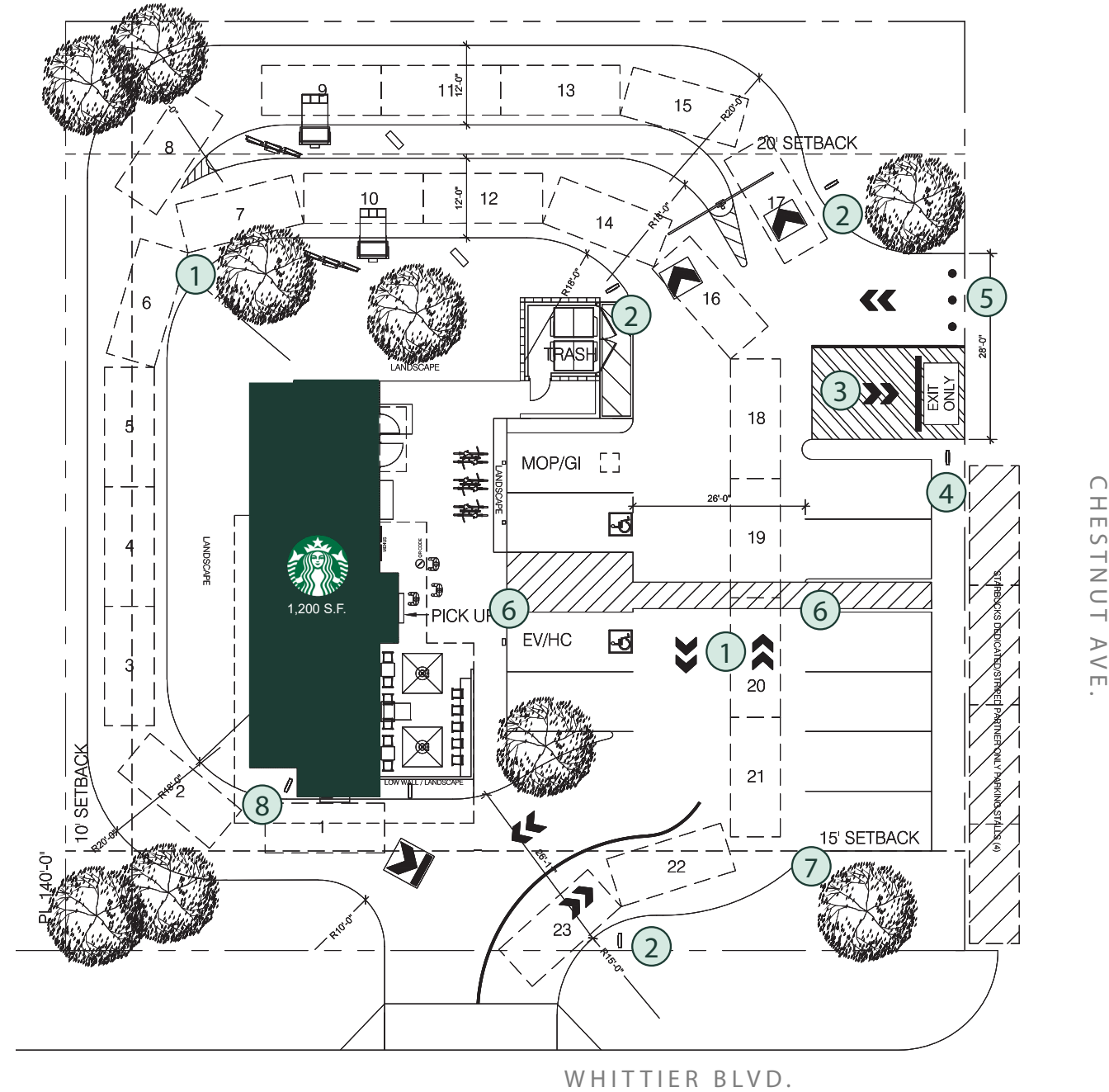

CHESTNUT AVE. AND WHITTIER BLVD. - DRIVE THRU MANAGEMENT PLAN

01/08/23 Starbucks Operations Approved



# DIRECTIONAL SIGN OPTIONS



**X** D/F DRIVE THRU ILLUMINATED DIRECTIONAL SIGNS~

Project:



Location:

Client Approval:

Date of Approval:

Sales Rep:

Paul L.

Date:

Drawn by:

L.S.

1		
2		
3		
4		
5		
6		

Electrical Requirement:

120 Volts

277 Volts



2101 Carrillo Privado, Ontario, CA 91761  
 (909) 930-0303 Fax: (909) 930-0308  
 E-mail: design@signindustries.tv  
 Web: www.signindustries.tv

All ideas, plans or arrangements indicated on this drawing are copyrighted and owned by Sign Industries Incorporated and shall not be reproduced, used by or disclosed to any persons, firm or corporation for any purpose whatsoever without written permission of Sign Industries Incorporated.

Drawing No

**22-256**



Page: **6.0**

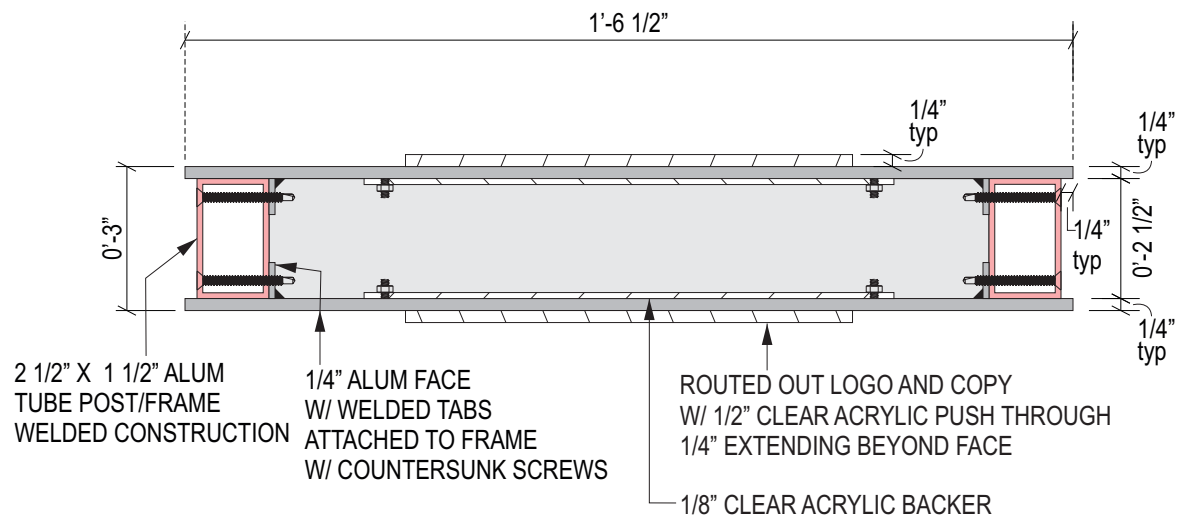

**1 CABINET SECTION DRAWING**

Scale: 3" = 1'

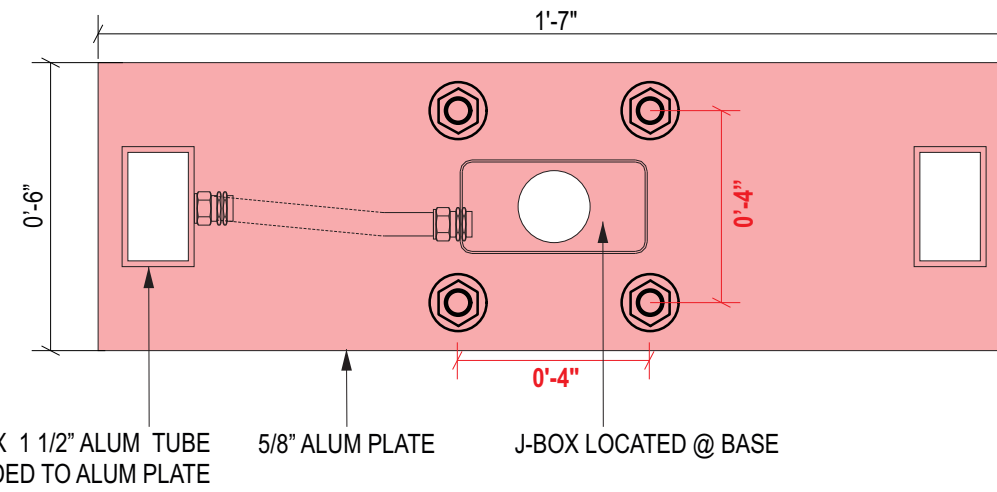

**2 PLATE DETAIL**

Scale: 3" = 1'



**BACK VIEW**

Project:



Location:

Client Approval:

Date of Approval:

Sales Rep:

Paul L.

Date:

Drawn by:

L.S.

1		
2		
3		
4		
5		
6		

Electrical Requirement:

120 Volts  277 Volts



2101 Carrillo Privado, Ontario, CA 91761  
 (909) 930-0303 Fax: (909) 930-0308  
 E-mail: design@signindustries.tv  
 Web: www.signindustries.tv

All ideas, plans or arrangements indicated on this drawing are copyrighted and owned by Sign Industries Incorporated and shall not be reproduced, used by or disclosed to any persons, firm or corporation for any purpose whatsoever without written permission of Sign Industries Incorporated.

Drawing No

**22-256**



Page: **3.0**



**FRONT VIEW**

COLOR LEGEND	
PMS/PAINT	VINYL
PMS 560 C	N/A
PMS 3425 C	3M 3630-126
RAL 7021M	NA

1/4" ALUM FACE REMOVABLE PAINTED TO MATCH PMS 560C

ROUTED OUT LOGO W/ 1/2" CLEAR ACRYLIC PUSH THROUGH SIREN LOGO WITH VINYL OVERLAY 3630-126 Dark Emerald Green

ROUTED OUT COPY W/ 1/2" CLEAR ACRYLIC PUSH THROUGH 3M WHITE TRANSLUCENT OVERLAY

2 1/2" X 1 1/2" ALUM TUBE POST/FRAME WELDED CONSTRUCTION PAINTED SATIN BLACK

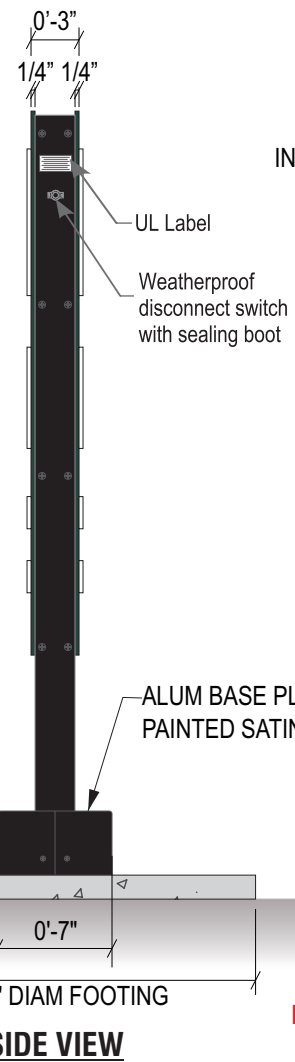

**SIDE VIEW**

SIGN CABINET TO BE INTERNALLY ILLUMINATED AROUND PERIMETER W/ SLOAN POSTERBOX MINI 6500K

UL Label

Weatherproof disconnect switch with sealing boot

ALUM BASE PLATE COVER PAINTED SATIN BLACK

1/2" DIAM ANCHOR RODS  
 DETAILS TBD BY ENGINEER

CONCRETE FOOTING 2500 PSI  
 DETAILS TBD BY ENGINEER

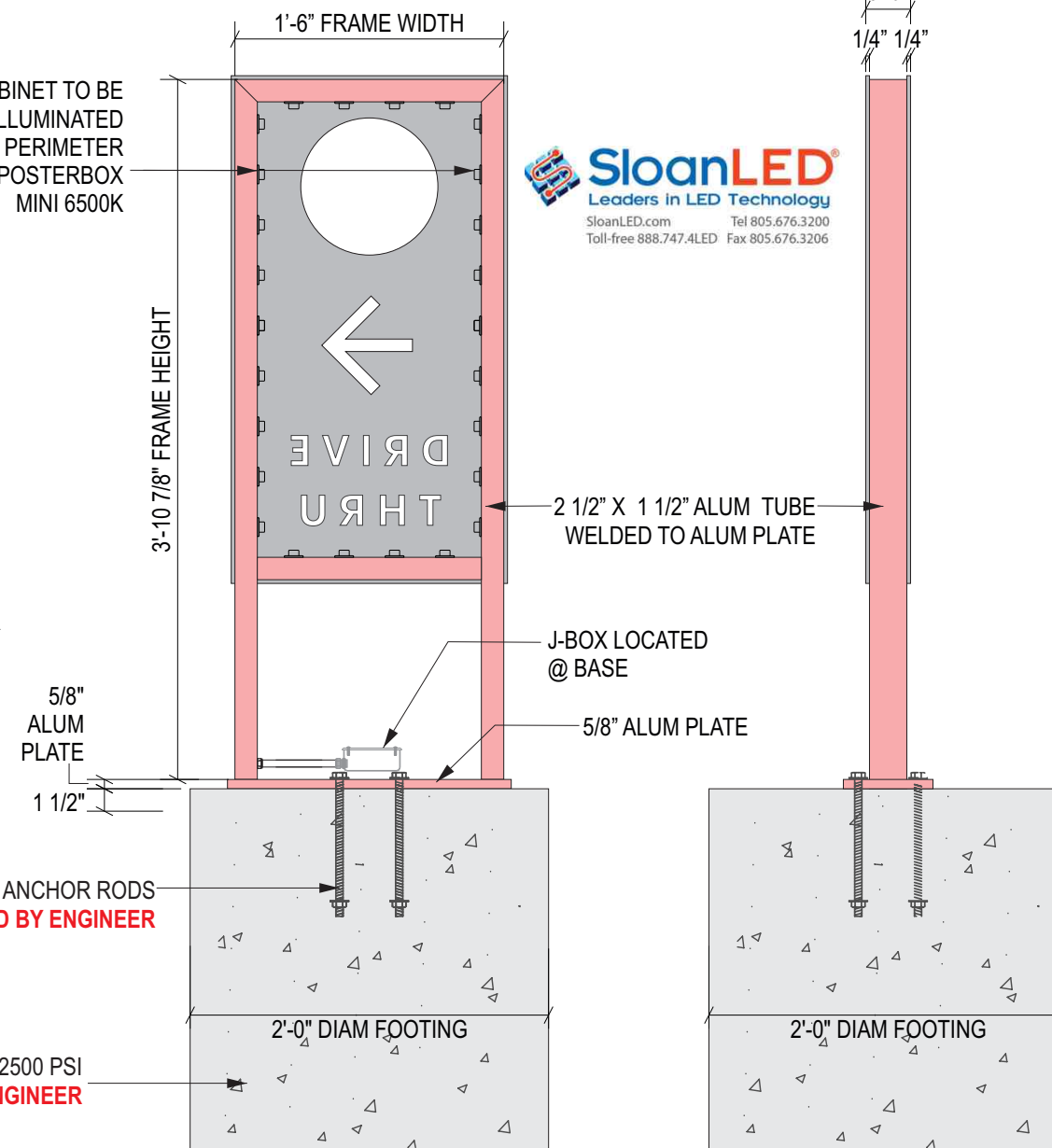

J-BOX LOCATED @ BASE

2 1/2" X 1 1/2" ALUM TUBE WELDED TO ALUM PLATE

5/8" ALUM PLATE

5/8" ALUM PLATE

1 1/2"

2'-0" DIAM FOOTING

2'-0" DIAM FOOTING

**C D/F DRIVE THRU ILLUMINATED DIRECTIONAL SIGNS~ Qty (1)**

Scale: 1" = 1'



1		
2		
3		
4		
5		
6		

Electrical Requirement:

120 Volts  277 Volts



2101 Carrillo Privado, Ontario, CA 91761  
 (909) 930-0303 Fax: (909) 930-0308  
 E-mail: design@signindustries.tv  
 Web: www.signindustries.tv

All ideas, plans or arrangements indicated on this drawing are copyrighted and owned by Sign Industries Incorporated and shall not be reproduced, used by or disclosed to any persons, firm or corporation for any purpose whatsoever without written permission of Sign Industries Incorporated.



WIND LOADS PER ASCE 7-16:

(29.3-1) $F=q_s \cdot G \cdot C_d \cdot A_s$	(26.10-1) $q_s = 0.00256 \cdot K_z \cdot K_{xt} \cdot K_d \cdot K_e \cdot V^2$
Risk Category: II	II
(26.5) Wind Speed (V): 150 mph per ATC Council	
(Table 26.6-1) Directional Fac. ( $K_d$ ): 0.85	(Table 26.6-1)
(26.7) Exposure Category: C	C
(26.8.2) Topo Fac. ( $K_{zt}$ ): 1	(unless unusual terrain)
(26.9) Ground Elev. Fac. ( $K_g$ ): 1	(for all elevation)
(26.11) Gust Effect Fac. ( $G$ ): 0.85	
s (height of affected area): 2.83 ft	
h (height): 4.10 ft	
B (width of affected area): 1.54 ft	
s/h= 0.69	
B/s= 0.54	
Force Coefficient (C): 1.698	(Table 29.3-1)
Velocity pressure exposure coefficient ( $K_z$ ):	(Table 29.3-1)
for s/h=1, add 10%	ASCE fig. 29.4-1 therefore: 1.0
If 2 poles, spacing between:	1.375 O.C.

Structure Component	Height at section c.g. ft	(Table 26.10-1) $K_z$ factor	$q_s$ psf	$q_s \cdot G \cdot C_d$ psf	$A_v$ ft <sup>2</sup>	Shear lb	Wind Moment lb-ft	
1	3.396	0.85	41.62	60.07	2.18	131	445	
2	1.979	0.85	41.62	60.07	2.18	131	259	
3	0.865	0.85	41.62	60.07	0.34	20	18	
4	0.292	0.85	41.62	60.07	0.56	34	10	
5	0.063	0.85	41.62	60.07	2.13	128	8	
Forces at finish grade							7	740
2 pole distribution factor							0.72	535

BASE PLATE DESIGN:

Base Plate Check		Size:		Nominal Yield Moment	
Mu= 0.74 k-ft	t: 0.625 in	Mnp=Fy*Z:	2.20 k-in		
Vu= 8.87 k-in	S: 4 in	$\phi_b$ :	0.9		
	Arm: 0.75 in	$\phi_b M_{np}$ :	1.98 k-in		
	b eff: 1.5 in	Demand/Capacity:	0.42 OKAY		
	n: 2 bolts				
Tgrp: 2.22 kip	Ftuw: 24 ksi	Nominal Yield Moment			
Tb= 1.11 kip/bolt	Ftyw: 15 ksi	Mnp=Fy*Z:	3.52 k-in		
Mu PL= 0.8 k-in	Fcyw: 15 ksi	$\phi_b$ :	0.9		
	Kt: 1	$\phi_b M_{np}$ :	3.16 k-in		
S (in <sup>3</sup> )= 0.098		Demand/Capacity:	0.26 OKAY		
Z (in <sup>3</sup> )= 0.146					

DIRECT BURIAL FOOTING:

Mu: 0.74 k-ft	(0.6Mu): 0.44 k-ft	$\omega$ : 1.3	IBC 1605.3.2
Vu: 8.87 kips	(0.6Vu): 0.27 kips		
P: 0.35 kips	S1: Sxd/3	244.44 psf	IBC 1806.1
Base: 2 ft dia.			IBC 1806.3.4
Depth: 2.75 ft deep	A: 2.34*P/(S1xb)	1.66 ft	IBC 1807.3.2.1
h: 1.67 ft			
S: 100 psf/ft	d: 0.5Av/(1+(4.36hA))	2.75 ft	
S': 266.667 psf/ft			IBC Table 1806.2

ALUMINUM COLUMN DESIGN:

Check Aluminum Rectangular Tube			
Mu= 0.535 k-ft	Mut= 6.424 k-in	Aluminum 6061-T6	
D= 2.5 in	S= 0.843 in <sup>3</sup>	Ftuw= 24 ksi	
B= 1.5 in	Z= 1.074 in <sup>3</sup>	Ftyw= 15 ksi	
T= 3/16 in	Req Z= 0.43	Fcyw= 15 ksi	
		Kt= 1	
Normal Yield Moment	Nominal Rupture Moment		
Mnp= 16.11 k-in	Mnp= 25.77 k-in		
$\phi_b$ = 0.9	$\phi_b$ = 0.9		
$\phi_b M_{np}$ = 14.50 k-in	$\phi_b M_{np}$ = 23.19 k-in		
D/C: 0.44	D/C: 0.28		

GENERAL NOTES:

- ALL WORK SHALL BE IN ACCORDANCE WITH THE LATEST EDITIONS OF THE STANDARD SPECIFICATIONS FOR PUBLIC WORKS CONSTRUCTION, THE 2019 CALIFORNIA BUILDING CODE (CBC), AND 2018 INTERNATIONAL BUILDING CODE (IBC). ANY CONFLICTS BETWEEN THESE DRAWINGS, STANDARDS NOTED HEREIN, PROJECT REQUIREMENTS, AND/OR OTHER REFERENCE DOCUMENTS SHALL BE BROUGHT TO THE ATTENTION OF THE CIVIL ENGINEER, WHERE CONFLICTS OCCUR, THE MOST STRINGENT REQUIREMENTS SHALL BE FOLLOWED.
- PROVIDE ISOLATION OF DISSIMILAR MATERIALS

DESIGN CRITERIA:

- STRUCTURE IS DESIGNED IN ACCORDANCE WITH ASCE 7-16 BASIC WIND SPEED: 150 MPH RISK CATEGORY: II EXPOSURE CATEGORY: C SITE CLASS: D OCCUPANCY CATEGORY: II SEISMIC DESIGN CATEGORY: D IMPORTANCE FACTOR: 1.0 RESPONSE MODIFICATION FACTOR: Rp=3.0 AMPLIFICATION FACTOR: Ap=2.5

CONCRETE:

- DESIGN AND CONSTRUCTION IN COMPLIANCE TO ACI 318-14.
- STEEL REINFORCEMENT IN CONCRETE ASTM A615 GRADE 60.
- COMPRESSIVE STRENGTH AT 28 DAYS: f'c=2,500 PSI MIN.
- PROVIDE A MINIMUM 3" CONCRETE COVER OVER ALL EMBEDDED STEEL.
- CONCRETE MUST BE POURED AGAINST UNDISTURBED EARTH SOIL.
- SOIL PASSIVE PRESSURE PER CBC CLASS 5 (100 PCF).

ALUMINUM

- FABRICATE AND ERECT ALUMINUM IN COMPLIANCE WITH THE MOST CURRENT ALUMINUM ASSOCIATION ALUMINUM DESIGN MANUAL 1.
- ALUMINUM ELEMENTS 6061-T6
- ALL SHOP AND FIELD WELDS SHALL BE PERFORMED BY AN AISC QUALITY CERTIFIED FABRICATOR.
- UNLESS A LARGER WELD SIZE IS INDICATED, PROVIDE MINIMUM SIZE OF WELD TO MATCH SMALLEST MEMBER/MATERIAL SIZE.
- ALL SHOP CONNECTIONS SHALL BE WELDED IN CONFORMANCE WITH STANDARDS BASED UPON THE CURRENT EDITION OF ANSI/AWS D1.2. WELDERS AND WELDING OPERATORS SHALL BE QUALIFIED AS PROVIDED IN THE CODE.

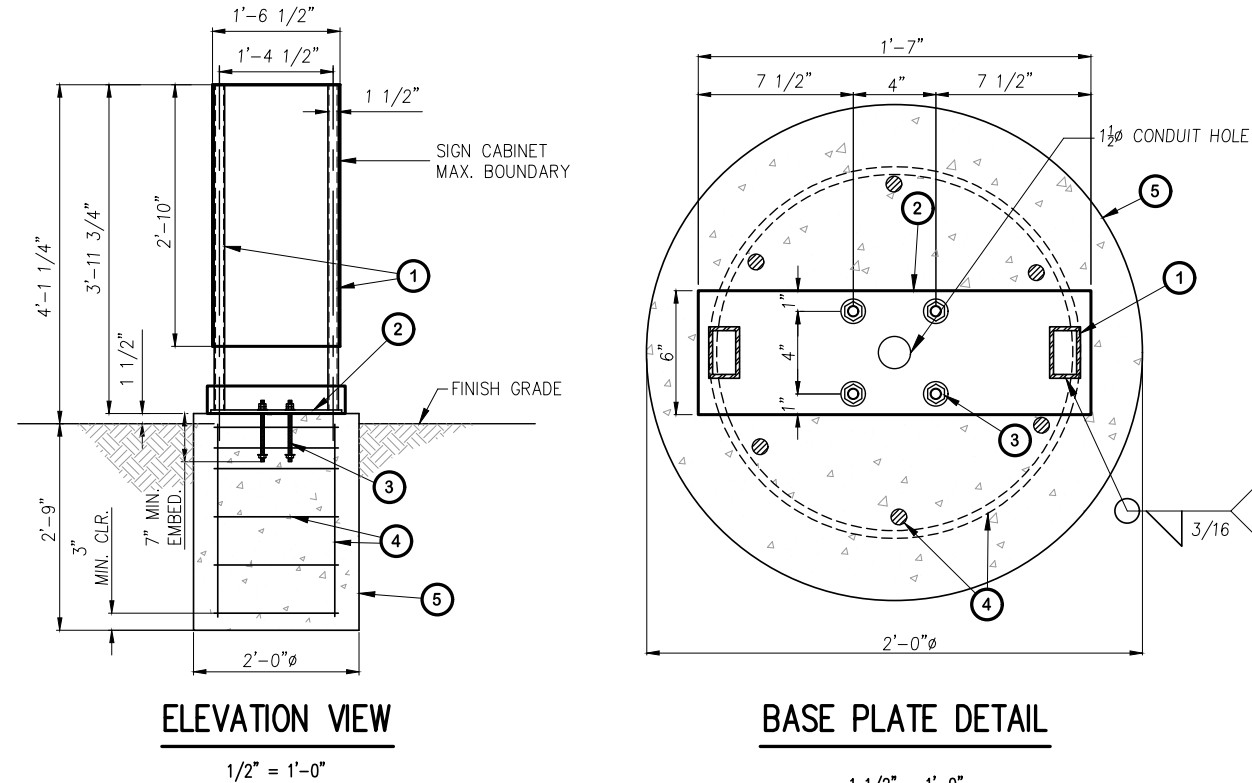

- (2)-2 1/2" x 1 1/2" x 3/16" ALUMINUM SQUARE PER ELEVATION AND BASE PLATE DETAIL HEREON.
- 5/8" THK. ALUMINUM BASE PLATE (19"x6") PER BASE PLATE DETAIL HEREON.
- (4) 1/2" THK. THREADED HOT DIPPED GALVANIZED ANCHOR RODS (ASTM F1554 GRADE 55) WITH GALVANIZED HARDWARE PER ELEVATION AND BASE PLATE DETAIL HEREON.
- HORIZ: (3) #3 TIES AT 3" O.C. AND THEN (3) #3 TIES AT 7" O.C. VERT: (6) #4 BAR SPACES EVENLY AROUND PERIMETER CLEARANCE 3" MIN. TO EDGE OF CONC.
- CONCRETE FOOTING PER PLAN AND SPECIFICATIONS HEREON.

REGISTERED PROFESSIONAL ENGINEER  
 YOSIMAR RAMOS  
 No. 89832  
 Exp. 6/30/23  
 CIVIL  
 STATE OF CALIFORNIA

*Yosimar Ramos*  
 YOSIMAR RAMOS  
 R.C.E. 89832  
 LIC. EXP 06/30/23

PREPARED BY:

**YR**  
 ENGINEERING LP

YR ENGINEERING LP  
 424 E. MAITLAND ST. STE. A  
 ONTARIO, CA 91761  
 PHONE: (626) 374-5881  
 EMAIL: YRAMOS@YRENGINEERING.COM

STARBUCKS DRIVE THRU SIGNAGE  
 DIRECTIONAL SIGNAGE  
 VARIOUS LOCATIONS, CALIFORNIA

PREPARED FOR: SIGN INDUSTRIES, INC.

CHECKED BY: YR      JOB NO: 2202-00      SHEET: 1 OF 1

DISREGARD PRINTS BEARING EARLIER REVISION DATES      02-03-22

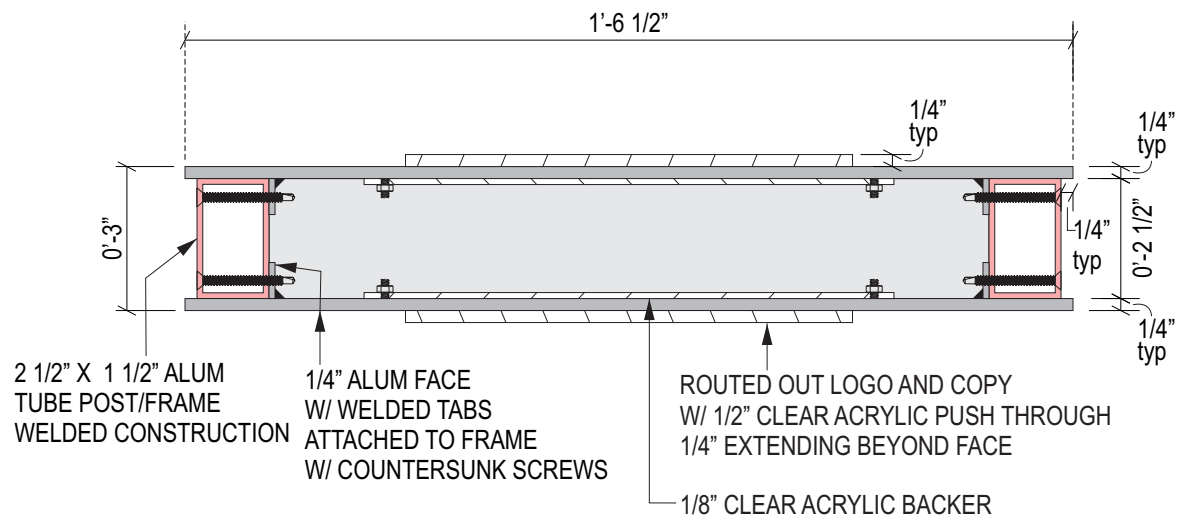

**1 CABINET SECTION DRAWING**

Scale: 3"= 1'

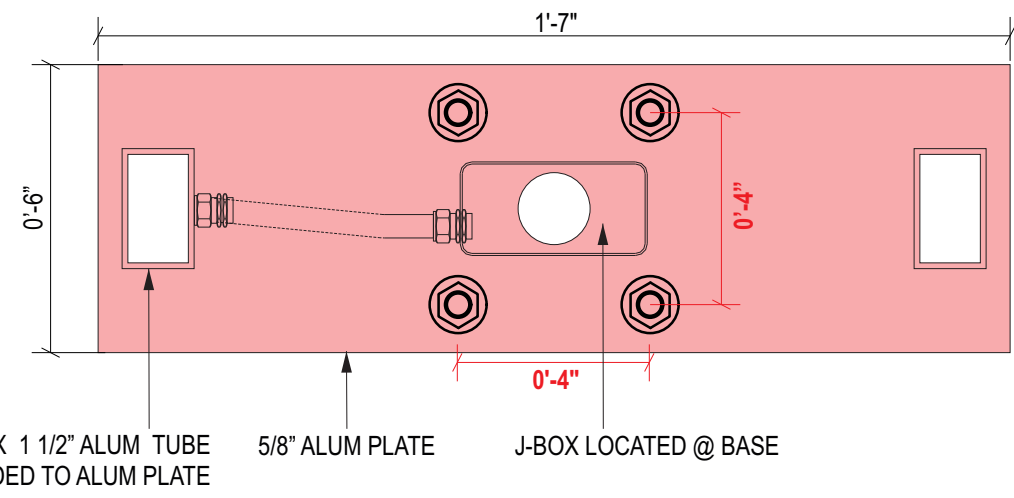

**2 PLATE DETAIL**

Scale: 3"= 1'



**BACK VIEW**

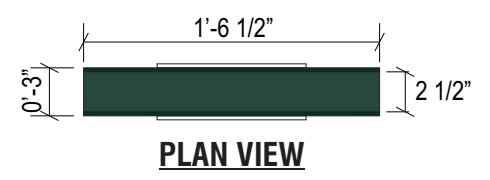

COLOR LEGEND	
PMS/PAINT	VINYL
PMS 560 C	N/A
PMS 3425 C	3M 3630-126
RAL 7021M	NA
TBV	TBV

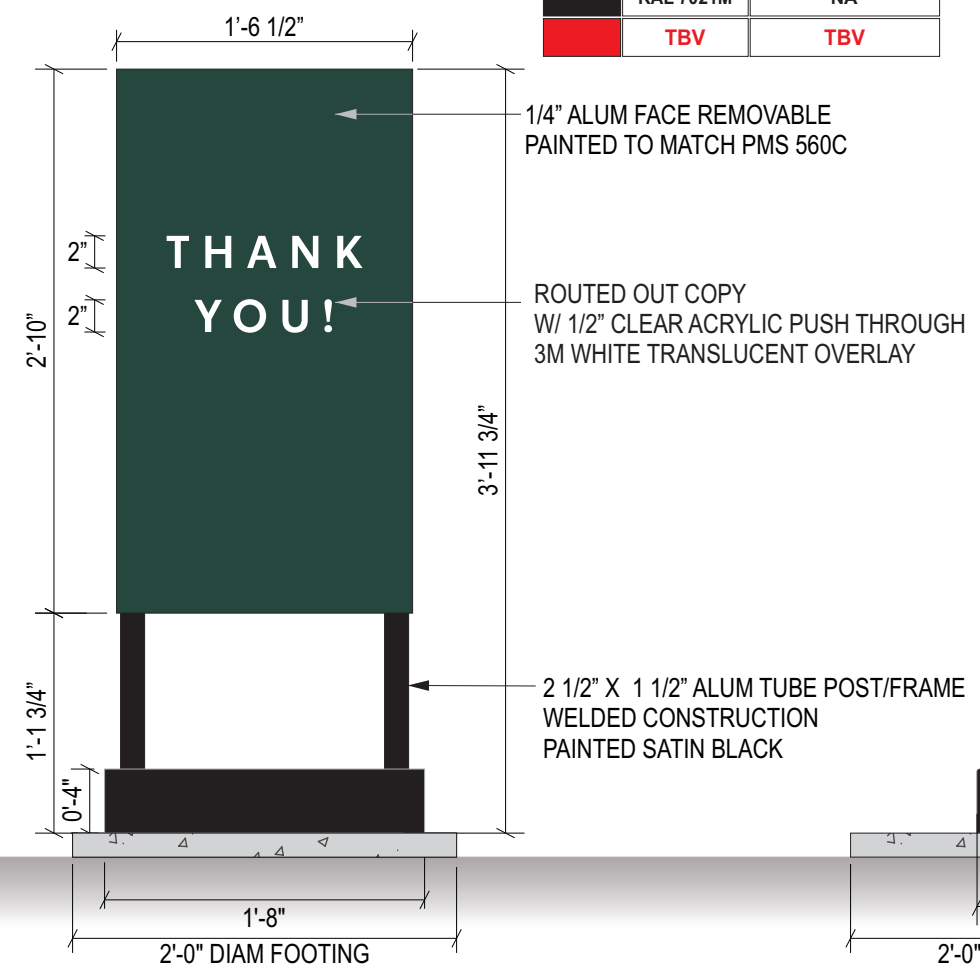

**FRONT VIEW**



**SIDE VIEW**

SIGN CABINET TO BE INTERNALLY ILLUMINATED AROUND PERIMETER W/ SLOAN POSTERBOX MINI 6500K

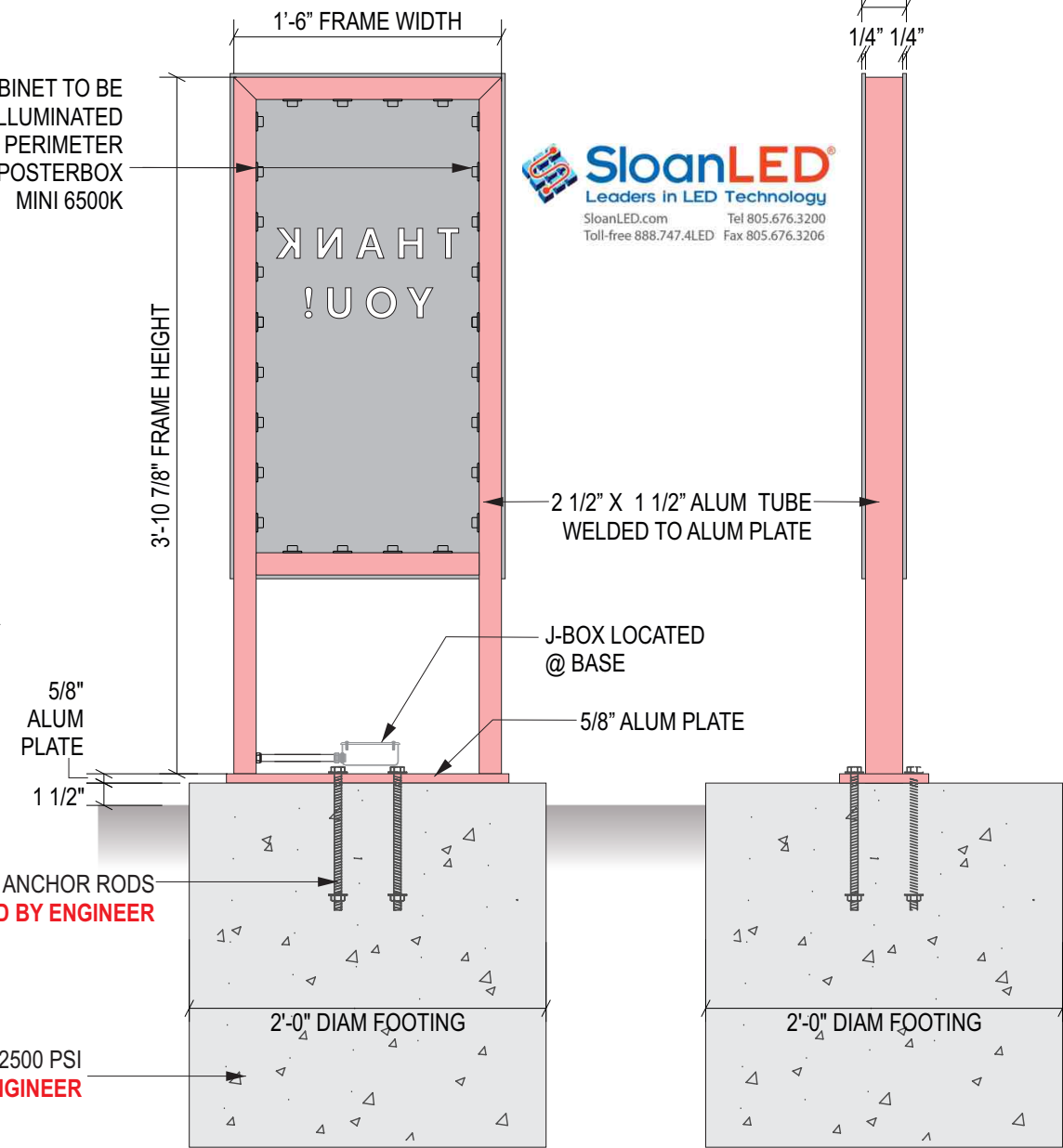

**D D/F DRIVE THRU ILLUMINATED DIRECTIONAL SIGNS~ Qty (1)**  
Scale: 1"= 1'



Project: Starbucks

Location:

Client Approval:

Date of Approval:

Sales Rep: Paul L.

Date: Drawn by: L.S.

1		
2		
3		
4		
5		
6		

Electrical Requirement:  
 120 Volts  277 Volts



2101 Carrillo Privado, Ontario, CA 91761  
(909) 930-0303 Fax: (909) 930-0308  
E-mail: design@signindustries.tv  
Web: www.signindustries.tv

All ideas, plans or arrangements indicated on this drawing are copyrighted and owned by Sign Industries Incorporated and shall not be reproduced, used by or disclosed to any persons, firm or corporation for any purpose whatsoever without written permission of Sign Industries Incorporated.

Drawing No  
**22-256**

Page: **4.0**



1		
2		
3		
4		
5		
6		

Electrical Requirement:

120 Volts  277 Volts



2101 Carrillo Privado, Ontario, CA 91761  
 (909) 930-0303 Fax: (909) 930-0308  
 E-mail: design@signindustries.tv  
 Web: www.signindustries.tv

All ideas, plans or arrangements indicated on this drawing are copyrighted and owned by Sign Industries Incorporated and shall not be reproduced, used by or disclosed to any persons, firm or corporation for any purpose whatsoever without written permission of Sign Industries Incorporated.

Drawing No

22-256



Page: 4.1

WIND LOADS PER ASCE 7-16:

(29.3-1) $F = q_s \cdot G \cdot C \cdot A_s$	(26.10-1) $q_s = 0.00256 \cdot K_z \cdot K_{xt} \cdot K_d \cdot K_e \cdot V^2$
Risk Category: II	II
(26.5) Wind Speed (V): 150 mph per ATC Council	
(Table 26.6-1) Directional Fac. ( $K_d$ ): 0.85	(Table 26.6-1)
(26.7) Exposure Category: C	C
(26.8.2) Topo Fac. ( $K_{zt}$ ): 1	(unless unusual terrain)
(26.9) Ground Elev. Fac. ( $K_g$ ): 1	(for all elevation)
(26.11) Gust Effect Fac. (G): 0.85	
s (height of affected area): 2.83 ft	
h (height): 4.10 ft	
B (width of affected area): 1.54 ft	
s/h = 0.69	
B/s = 0.54	
Force Coefficient (C): 1.698	(Table 29.3-1)
Velocity pressure exposure coefficient ( $K_z$ ):	(Table 29.3-1)
for s/h=1, add 10%	ASCE fig. 29.4-1 therefore: 1.0
If 2 poles, spacing between:	1.375 O.C.

Structure Component	Height at section c.g. ft	(Table 26.10-1) $K_z$ factor	$q_s$ psf	$q_s \cdot G \cdot C$ psf	$A_v$ ft <sup>2</sup>	Shear lb	Wind Moment lb-ft
1	3.396	0.85	41.62	60.07	2.18	131	445
2	1.979	0.85	41.62	60.07	2.18	131	259
3	0.865	0.85	41.62	60.07	0.34	20	18
4	0.292	0.85	41.62	60.07	0.56	34	10
5	0.063	0.85	41.62	60.07	2.13	128	8
Forces at finish grade						7	740
2 pole distribution factor						0.72	535

BASE PLATE DESIGN:

Base Plate Check		Size:		Nominal Yield Moment	
Mu = 0.74 k-ft	t = 0.625 in	Mnp = Fy * Z:	2.20 k-in		
Vu = 8.87 k-in	S = 4 in	$\phi_b$ :	0.9		
	Arm = 0.75 in	$\phi_b M_{np}$ :	1.98 k-in		
	b eff = 1.5 in	Demand/Capacity:	0.42 OKAY		
	n = 2 bolts				
Tgrp = 2.22 kip	Ftuw = 24 ksi	Nominal Yield Moment			
Tb = 1.11 kip/bolt	Ftyw = 15 ksi	Mnp = Fy * Z:	3.52 k-in		
Mu PL = 0.8 k-in	Fcyw = 15 ksi	$\phi_b$ :	0.9		
	Kt = 1	$\phi_b M_{np}$ :	3.16 k-in		
S (in <sup>3</sup> ) = 0.098		Demand/Capacity:	0.26 OKAY		
Z (in <sup>3</sup> ) = 0.146					

DIRECT BURIAL FOOTING:

Mu: 0.74 k-ft	(0.6Mu): 0.44 k-ft	w: 1.3	IBC 1605.3.2
Vu: 8.87 kips	(0.6Vu): 0.27 kips		
P: 0.35 kips	S1: Sxd/3	244.44 psf	IBC 1806.1
Base: 2 ft dia.			IBC 1806.3.4
Depth: 2.75 ft deep	A: 2.34 * P / (S1 * b)	1.66 ft	IBC 1807.3.2.1
h: 1.67 ft			
S: 100 psf/ft	d: 0.5Av(1+(4.36h/A))	2.75 ft	
S': 266.667 psf/ft			IBC Table 1806.2

ALUMINUM COLUMN DESIGN:

Check Aluminum Rectangular Tube			
Mu = 0.535 k-ft	Mut = 6.424 k-in	Aluminum 6061-T6	
D = 2.5 in	S = 0.843 in <sup>3</sup>	Ftuw = 24 ksi	
B = 1.5 in	Z = 1.074 in <sup>3</sup>	Ftyw = 15 ksi	
T = 3/16 in	Req Z = 0.43	Fcyw = 15 ksi	
		Kt = 1	
Normal Yield Moment	Nominal Rupture Moment		
Mnp = 16.11 k-in	Mnp = 25.77 k-in		
$\phi_b$ = 0.9	$\phi_b$ = 0.9		
$\phi_b M_{np}$ = 14.50 k-in	$\phi_b M_{np}$ = 23.19 k-in		
D/C: 0.44	D/C: 0.28		

GENERAL NOTES:

- ALL WORK SHALL BE IN ACCORDANCE WITH THE LATEST EDITIONS OF THE STANDARD SPECIFICATIONS FOR PUBLIC WORKS CONSTRUCTION, THE 2019 CALIFORNIA BUILDING CODE (CBC), AND 2018 INTERNATIONAL BUILDING CODE (IBC). ANY CONFLICTS BETWEEN THESE DRAWINGS, STANDARDS NOTED HEREIN, PROJECT REQUIREMENTS, AND/OR OTHER REFERENCE DOCUMENTS SHALL BE BROUGHT TO THE ATTENTION OF THE CIVIL ENGINEER, WHERE CONFLICTS OCCUR, THE MOST STRINGENT REQUIREMENTS SHALL BE FOLLOWED.
- PROVIDE ISOLATION OF DISSIMILAR MATERIALS

DESIGN CRITERIA:

- STRUCTURE IS DESIGNED IN ACCORDANCE WITH ASCE 7-16
- BASIC WIND SPEED: 150 MPH
- RISK CATEGORY: II
- EXPOSURE CATEGORY: C
- SITE CLASS: D
- OCCUPANCY CATEGORY: II
- SEISMIC DESIGN CATEGORY: D
- IMPORTANCE FACTOR: 1.0
- RESPONSE MODIFICATION FACTOR: Rp=3.0
- AMPLIFICATION FACTOR: Ap=2.5

CONCRETE:

- DESIGN AND CONSTRUCTION IN COMPLIANCE TO ACI 318-14.
- STEEL REINFORCEMENT IN CONCRETE ASTM A615 GRADE 60.
- COMPRESSIVE STRENGTH AT 28 DAYS: f'c=2,500 PSI MIN.
- PROVIDE A MINIMUM 3" CONCRETE COVER OVER ALL EMBEDDED STEEL.
- CONCRETE MUST BE POURED AGAINST UNDISTURBED EARTH SOIL.
- SOIL PASSIVE PRESSURE PER CBC CLASS 5 (100 PCF).

ALUMINUM

- FABRICATE AND ERECT ALUMINUM IN COMPLIANCE WITH THE MOST CURRENT ALUMINUM ASSOCIATION ALUMINUM DESIGN MANUAL 1.
- ALUMINUM ELEMENTS 6061-T6
- ALL SHOP AND FIELD WELDS SHALL BE PERFORMED BY AN AISC QUALITY CERTIFIED FABRICATOR.
- UNLESS A LARGER WELD SIZE IS INDICATED, PROVIDE MINIMUM SIZE OF WELD TO MATCH SMALLEST MEMBER/MATERIAL SIZE.
- ALL SHOP CONNECTIONS SHALL BE WELDED IN CONFORMANCE WITH STANDARDS BASED UPON THE CURRENT EDITION OF ANSI/AWS D1.2. WELDERS AND WELDING OPERATORS SHALL BE QUALIFIED AS PROVIDED IN THE CODE.

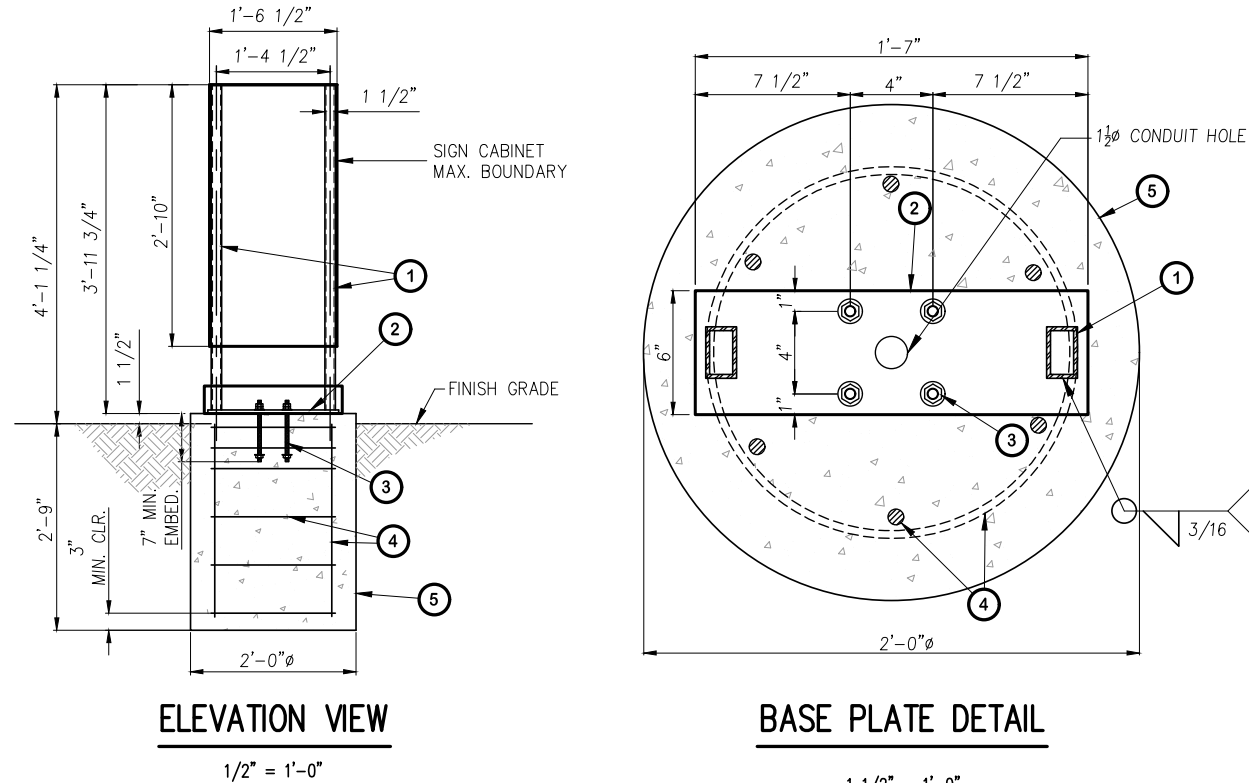

- (2)-2 1/2" x 1 1/2" x 3/16" ALUMINUM SQUARE PER ELEVATION AND BASE PLATE DETAIL HEREON.
- 5/8" THK. ALUMINUM BASE PLATE (19"x6") PER BASE PLATE DETAIL HEREON.
- (4) 1/2" THREADED HOT DIPPED GALVANIZED ANCHOR RODS (ASTM F1554 GRADE 55) WITH GALVANIZED HARDWARE PER ELEVATION AND BASE PLATE DETAIL HEREON.
- HORIZ: (3) #3 TIES AT 3" O.C. AND THEN (3) #3 TIES AT 7" O.C. VERT: (6) #4 BAR SPACES EVENLY AROUND PERIMETER CLEARANCE 3" MIN. TO EDGE OF CONC.
- CONCRETE FOOTING PER PLAN AND SPECIFICATIONS HEREON.

REGISTERED PROFESSIONAL ENGINEER  
 YOSIMAR RAMOS  
 No. 89832  
 Exp. 6/30/23  
 CIVIL  
 STATE OF CALIFORNIA

*Yosimar Ramos*  
 YOSIMAR RAMOS  
 R.C.E. 89832  
 LIC. EXP 06/30/23

PREPARED BY:

YR ENGINEERING LP  
 424 E. MAITLAND ST. STE. A  
 ONTARIO, CA 91761  
 PHONE: (626) 374-5881  
 EMAIL: YRAMOS@YRENGINEERING.COM

STARBUCKS DRIVE THRU SIGNAGE  
 DIRECTIONAL SIGNAGE  
 VARIOUS LOCATIONS, CALIFORNIA

PREPARED FOR: SIGN INDUSTRIES, INC.

CHECKED BY: YR      JOB NO: 2202-00      SHEET: 1 OF 1

DISREGARD PRINTS BEARING EARLIER REVISION DATES      02-03-22

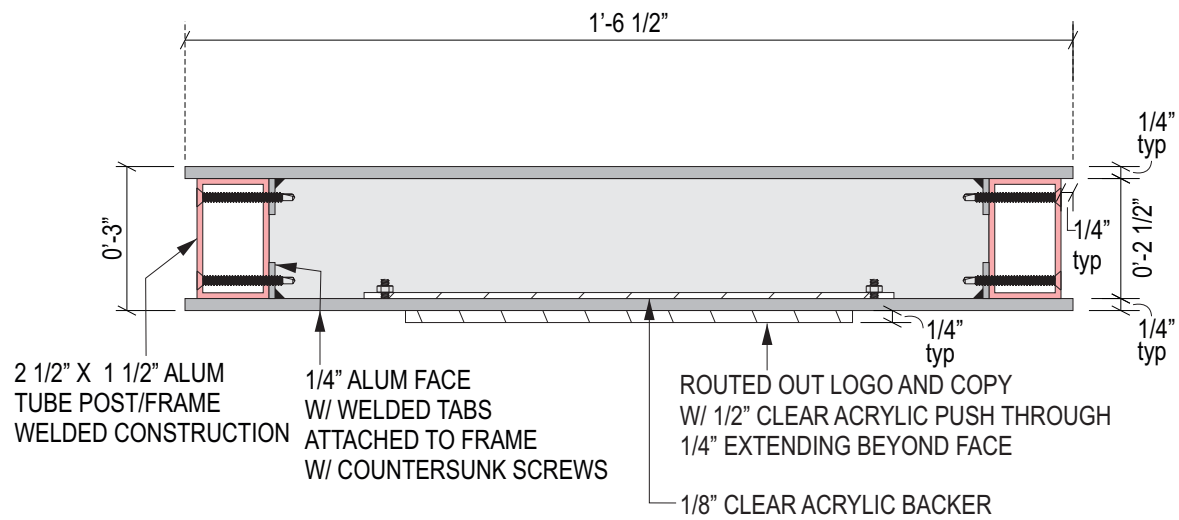

**1 CABINET SECTION DRAWING**

Scale: 3" = 1'

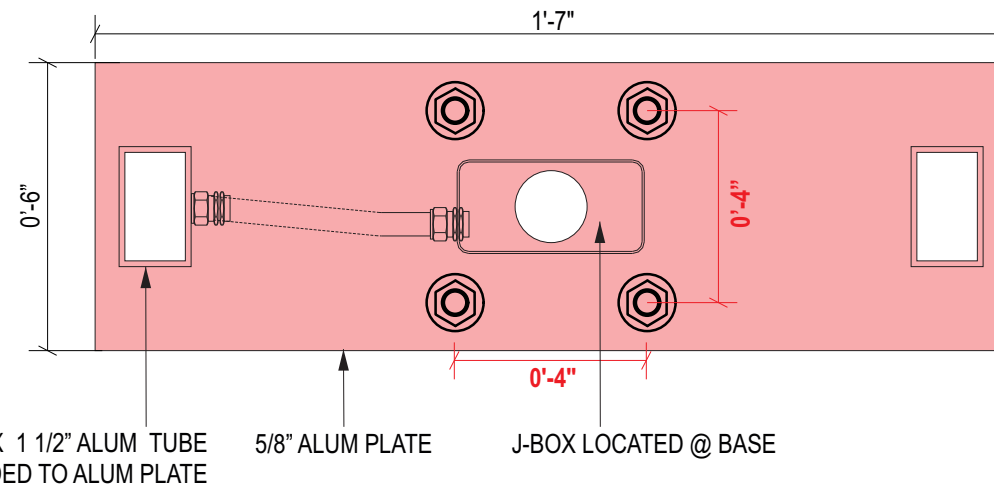

**2 PLATE DETAIL**

Scale: 3" = 1'

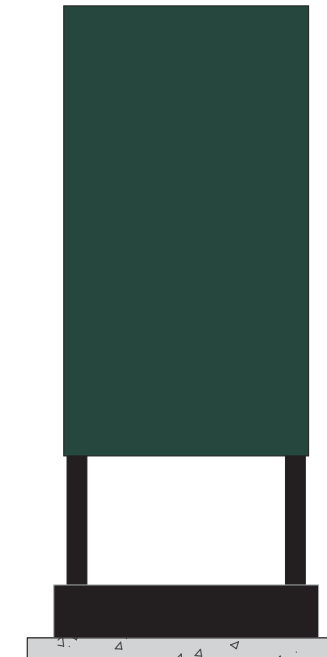

**BACK VIEW**

Project:



Location:

Client Approval:

Date of Approval:

Sales Rep:

Paul L.

Date:

Drawn by:

L.S.

1		
2		
3		
4		
5		
6		

Electrical Requirement:

120 Volts  277 Volts



2101 Carrillo Privado, Ontario, CA 91761  
 (909) 930-0303 Fax: (909) 930-0308  
 E-mail: design@signindustries.tv  
 Web: www.signindustries.tv

All ideas, plans or arrangements indicated on this drawing are copyrighted and owned by Sign Industries Incorporated and shall not be reproduced, used by or disclosed to any persons, firm or corporation for any purpose whatsoever without written permission of Sign Industries Incorporated.

Drawing No

**22-256**



Page: **5.0**

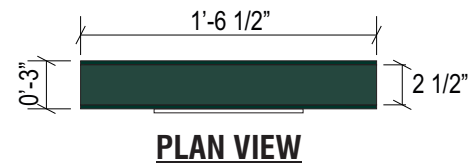

**PLAN VIEW**

COLOR LEGEND	
PMS/PAINT	VINYL
PMS 560 C	N/A
PMS 3425 C	3M 3630-126
RAL 7021M	NA

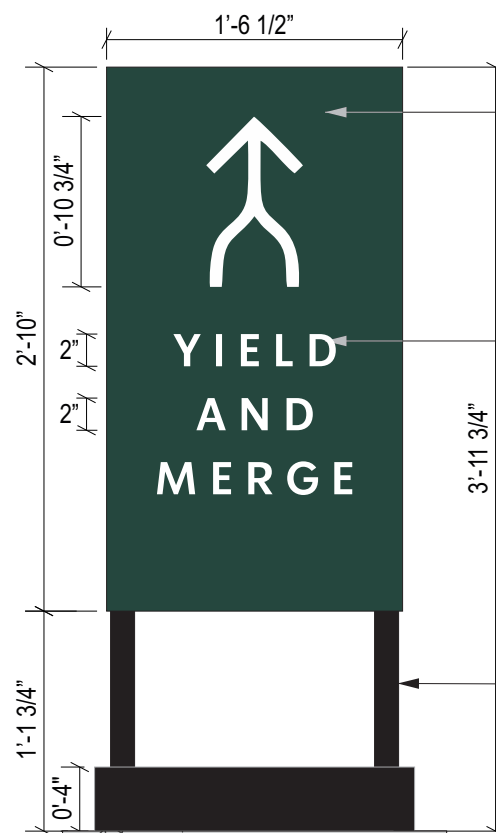

**FRONT VIEW**

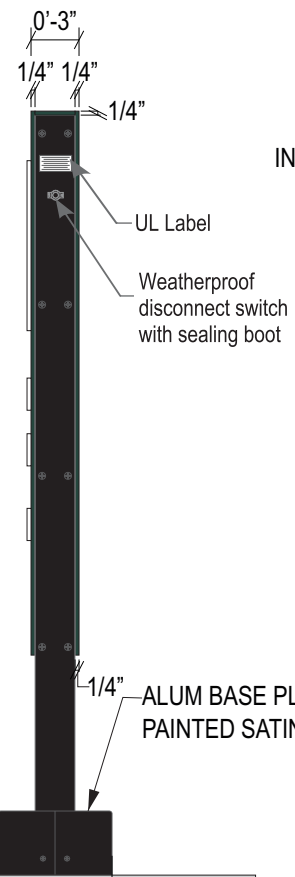

**SIDE VIEW**

SIGN CABINET TO BE INTERNALLY ILLUMINATED AROUND PERIMETER W/ SLOAN POSTERBOX MINI 6500K

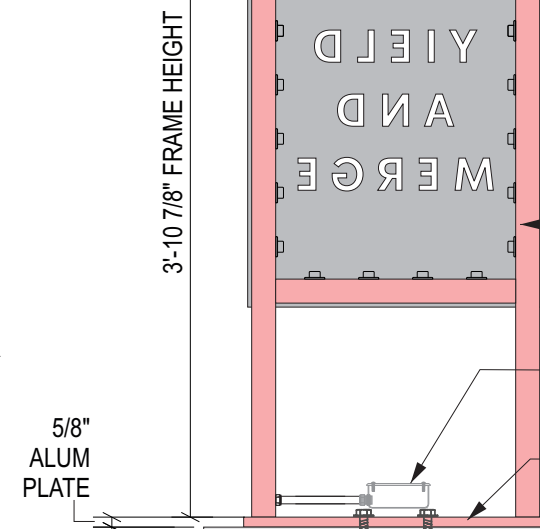

1/2" DIAM ANCHOR RODS  
 DETAILS TBD BY ENGINEER

CONCRETE FOOTING 2500 PSI  
 DETAILS TBD BY ENGINEER

**E D/F DRIVE THRU ILLUMINATED DIRECTIONAL SIGNS~ Qty (1)**

Scale: 1" = 1'



1		
2		
3		
4		
5		
6		

Electrical Requirement:

120 Volts  277 Volts



2101 Carrillo Privado, Ontario, CA 91761  
 (909) 930-0303 Fax: (909) 930-0308  
 E-mail: design@signindustries.tv  
 Web: www.signindustries.tv

All ideas, plans or arrangements indicated on this drawing are copyrighted and owned by Sign Industries Incorporated and shall not be reproduced, used by or disclosed to any persons, firm or corporation for any purpose whatsoever without written permission of Sign Industries Incorporated.

Drawing No

22-256



Page: 5.1

WIND LOADS PER ASCE 7-16:

(29.3-1) $F=q_s \cdot G \cdot C_d \cdot A_s$	(26.10-1) $q_s = 0.00256 \cdot K_z \cdot K_{xt} \cdot K_d \cdot K_e \cdot V^2$
Risk Category: II	II
(26.5) Wind Speed (V): 150 mph per ATC Council	
(Table 26.6-1) Directional Fac. ( $K_d$ ): 0.85	(Table 26.6-1)
(26.7) Exposure Category: C	C
(26.8.2) Topo Fac. ( $K_{zt}$ ): 1	(unless unusual terrain)
(26.9) Ground Elev. Fac. ( $K_z$ ): 1	(for all elevation)
(26.11) Gust Effect Fac. (G): 0.85	
s (height of affected area): 2.83 ft	
h (height): 4.10 ft	
B (width of affected area): 1.54 ft	
s/h= 0.69	
B/s= 0.54	
Force Coefficient (C): 1.698	(Table 29.3-1)
Velocity pressure exposure coefficient ( $K_z$ ):	(Table 29.3-1)
for s/h=1, add 10%	ASCE fig. 29.4-1 therefore: 1.0
If 2 poles, spacing between:	1.375 O.C.

Structure Component	Height at section c.g. ft	(Table 26.10-1) $K_z$ factor	$q_s$ psf	$q_s \cdot G \cdot C_d$ ft <sup>2</sup>	Shear lb	Wind Moment lb-ft	
1	3.396	0.85	41.62	60.07	131	445	
2	1.979	0.85	41.62	60.07	131	259	
3	0.865	0.85	41.62	60.07	20	18	
4	0.292	0.85	41.62	60.07	34	10	
5	0.063	0.85	41.62	60.07	128	8	
Forces at finish grade						7	740
2 pole distribution factor						0.72	321
						535	

BASE PLATE DESIGN:

Base Plate Check		Size:		Nominal Yield Moment	
Mu= 0.74 k-ft	t: 0.625 in	Mnp=Fy*Z:	2.20 k-in		
Vu= 8.87 k-in	S: 4 in	$\phi_b$ :	0.9		
	Arm: 0.75 in	$\phi_b M_{np}$ :	1.98 k-in		
	b eff: 1.5 in	Demand/Capacity:	0.42	OKAY	
Tgrp: 2.22 kip	n: 2 bolts				
Tb= 1.11 kip/bolt	Ftuw: 24 ksi	Nominal Yield Moment	3.52 k-in		
Mu PL= 0.8 k-in	Ftyw: 15 ksi	Mnp=Fy*Z:	3.52 k-in		
	Fcyw: 15 ksi	$\phi_b$ :	0.9		
S (in <sup>3</sup> )= 0.098	Kt: 1	$\phi_b M_{np}$ :	3.16 k-in		
Z (in <sup>3</sup> )= 0.146		Demand/Capacity:	0.26	OKAY	

DIRECT BURIAL FOOTING:

Mu: 0.74 k-ft	(0.6Mu): 0.44 k-ft	w: 1.3	IBC 1605.3.2
Vu: 8.87 kips	(0.6Vu): 0.27 kips		
P: 0.35 kips	S1: Svd/3	244.44 psf	IBC 1806.1
Base: 2 ft dia.			IBC 1806.3.4
Depth: 2.75 ft deep	A: 2.34*P/(S1xb)	1.66 ft	IBC 1807.3.2.1
h: 1.67 ft			
S: 100 psf/ft	d: 0.5Av/(1+(4.36hA))	2.75 ft	
S': 266.667 psf/ft			IBC Table 1806.2

ALUMINUM COLUMN DESIGN:

Check Aluminum Rectangular Tube			
Mu= 0.535 k-ft	Mut= 6.424 k-in	Aluminum 6061-T6	
D= 2.5 in	S= 0.843 in <sup>3</sup>	Ftuw= 24 ksi	
B= 1.5 in	Z= 1.074 in <sup>3</sup>	Ftyw= 15 ksi	
T= 3/16 in	Req Z= 0.43	Fcyw= 15 ksi	
		Kt= 1	
Normal Yield Moment		Nominal Rupture Moment	
Mnp= 16.11 k-in	$\phi_b$ = 0.9	Mnp= 25.77 k-in	
$\phi_b M_{np}$ = 14.50 k-in		$\phi_b M_{np}$ = 23.19 k-in	
D/C: 0.44		D/C: 0.28	

GENERAL NOTES:

- ALL WORK SHALL BE IN ACCORDANCE WITH THE LATEST EDITIONS OF THE STANDARD SPECIFICATIONS FOR PUBLIC WORKS CONSTRUCTION, THE 2019 CALIFORNIA BUILDING CODE (CBC), AND 2018 INTERNATIONAL BUILDING CODE (IBC). ANY CONFLICTS BETWEEN THESE DRAWINGS, STANDARDS NOTED HEREIN, PROJECT REQUIREMENTS, AND/OR OTHER REFERENCE DOCUMENTS SHALL BE BROUGHT TO THE ATTENTION OF THE CIVIL ENGINEER, WHERE CONFLICTS OCCUR, THE MOST STRINGENT REQUIREMENTS SHALL BE FOLLOWED.
- PROVIDE ISOLATION OF DISSIMILAR MATERIALS

DESIGN CRITERIA:

- STRUCTURE IS DESIGNED IN ACCORDANCE WITH ASCE 7-16
- BASIC WIND SPEED: 150 MPH
- RISK CATEGORY: II
- EXPOSURE CATEGORY: C
- SITE CLASS: D
- OCCUPANCY CATEGORY: II
- SEISMIC DESIGN CATEGORY: D
- IMPORTANCE FACTOR: 1.0
- RESPONSE MODIFICATION FACTOR: Rp=3.0
- AMPLIFICATION FACTOR: Ap=2.5

CONCRETE:

- DESIGN AND CONSTRUCTION IN COMPLIANCE TO ACI 318-14.
- STEEL REINFORCEMENT IN CONCRETE ASTM A615 GRADE 60.
- COMPRESSIVE STRENGTH AT 28 DAYS: f'c=2,500 PSI MIN.
- PROVIDE A MINIMUM 3" CONCRETE COVER OVER ALL EMBEDDED STEEL.
- CONCRETE MUST BE POURED AGAINST UNDISTURBED EARTH SOIL.
- SOIL PASSIVE PRESSURE PER CBC CLASS 5 (100 PCF).

ALUMINUM

- FABRICATE AND ERECT ALUMINUM IN COMPLIANCE WITH THE MOST CURRENT ALUMINUM ASSOCIATION ALUMINUM DESIGN MANUAL 1.
- ALUMINUM ELEMENTS 6061-T6
- ALL SHOP AND FIELD WELDS SHALL BE PERFORMED BY AN AISC QUALITY CERTIFIED FABRICATOR.
- UNLESS A LARGER WELD SIZE IS INDICATED, PROVIDE MINIMUM SIZE OF WELD TO MATCH SMALLEST MEMBER/MATERIAL SIZE.
- ALL SHOP CONNECTIONS SHALL BE WELDED IN CONFORMANCE WITH STANDARDS BASED UPON THE CURRENT EDITION OF ANSI/AWS D1.2. WELDERS AND WELDING OPERATORS SHALL BE QUALIFIED AS PROVIDED IN THE CODE.

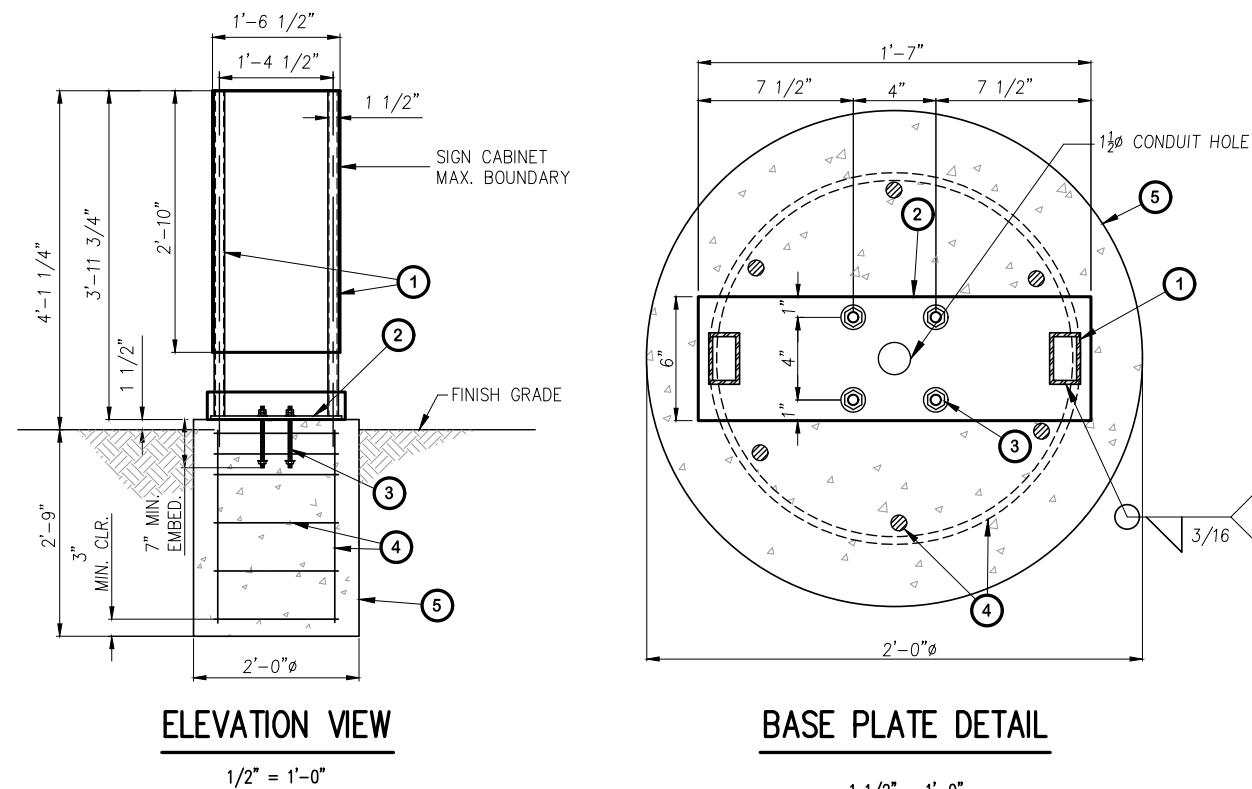

- (2)-2 1/2" x 1 1/2" x 3/16" ALUMINUM SQUARE PER ELEVATION AND BASE PLATE DETAIL HEREON.
- 5/8" THK. ALUMINUM BASE PLATE (19"x6") PER BASE PLATE DETAIL HEREON.
- (4) 1/2" THREADED HOT DIPPED GALVANIZED ANCHOR RODS (ASTM F1554 GRADE 55) WITH GALVANIZED HARDWARE PER ELEVATION AND BASE PLATE DETAIL HEREON.
- HORIZ: (3) #3 TIES AT 3" O.C. AND THEN (3) #3 TIES AT 7" O.C. VERT: (6) #4 BAR SPACES EVENLY AROUND PERIMETER CLEARANCE 3" MIN. TO EDGE OF CONC.
- CONCRETE FOOTING PER PLAN AND SPECIFICATIONS HEREON.

REGISTERED PROFESSIONAL ENGINEER  
 YOSIMAR RAMOS  
 No. 89832  
 Exp. 6/30/23  
 CIVIL  
 STATE OF CALIFORNIA

*Yosimar Ramos*  
 YOSIMAR RAMOS  
 R.C.E. 89832  
 LIC. EXP 06/30/23

PREPARED BY:

YR ENGINEERING LP  
 424 E. MAITLAND ST. STE. A  
 ONTARIO, CA 91761  
 PHONE: (626) 374-5881  
 EMAIL: YRAMOS@YRENGINEERING.COM

STARBUCKS DRIVE THRU SIGNAGE  
 DIRECTIONAL SIGNAGE  
 VARIOUS LOCATIONS, CALIFORNIA

PREPARED FOR: SIGN INDUSTRIES, INC.

CHECKED BY: YR      JOB NO: 2202-00      SHEET: 1 OF 1

DISREGARD PRINTS BEARING EARLIER REVISION DATES      02-03-22

# F CLEARANCE BAR - ILLUMINATED

SBC-#

Qty. 1

Note: GC responsible for placing qty. two (2) 3 position switches inside of the building adjacent to the pick up window and responsible for running the 4 switch controlled circuits to the clearance bar footer when footer is poured.

To be controlled from within building.

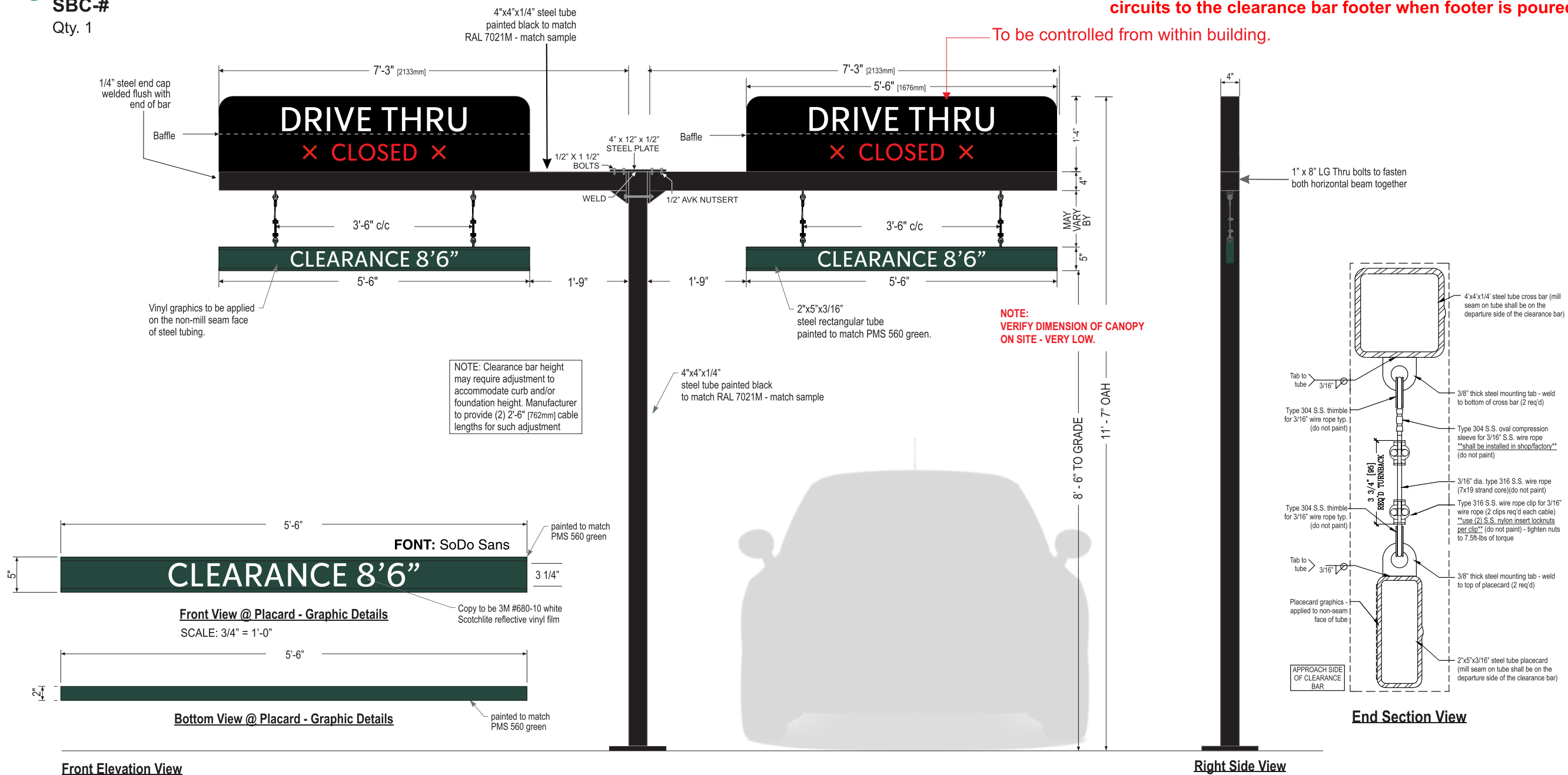

Front Elevation View

SCALE: 1/2" = 1'-0"

## SIGN SPECIFICATIONS:

### Scraper Bar:

- 2" x 5'-6" x 5" steel tube painted to match PMS 560 green.
- Flush steel end caps painted to match PMS 560 green.
- Copy and chevrons to be 1st surface computer cut 3M #680-10 white Scotchlite reflective vinyl film.
- Bottom striping to be 1st surface computer cut 3M #680-10 white Scotchlite reflective vinyl film. Striping extends 3/8" [10mm] onto front face.
- Suspend from support with SS cable & hardware. Cable provided requires field adjustment for proper clearance height.

### DT Cabinet(s):

- 16" x 66" x 4" w/ 3" Radius Top Corners Fabricated .090" [2mm] aluminum housing painted black to match RAL 7021M
- Drive Thru copy backed up with .125" white polycarb. All polycarb face elements to be attached to aluminum face panel with weld studs. The red "X Closed X" copy is routed and backed with 2423 Red acrylic with light diffuser on 2nd surface. A baffle will be located between "Drive Thru" and "X CLOSED X". "Drive Thru" copy will be illuminated when the lane is open. "Drive Thru" copy will turn off and "X CLOSED X" copy will be illuminated when the lane is closed.
- Welded aluminum construction with no visible fasteners.
- All fasteners used in the assembly of internal components shall be coated to prevent corrosion.
- Internal structure of cabinet shall be per approved shop drawings.
- Graphic elements are internally illuminated using Sloan Prism Enlighten LEDs. LED's to be mounted on back of cabinet with self-contained power supply. All electrical components are removable for service.

### Support:

- Supporting structure will be all welded steel tube construction painted black to match RAL 7021M as per approved shop drawings.
- New foundation may be required.
- Clearance bar will be mounted on a concrete pedestal. Will be attached with anchor bolts and base plate (engineering to be confirmed)

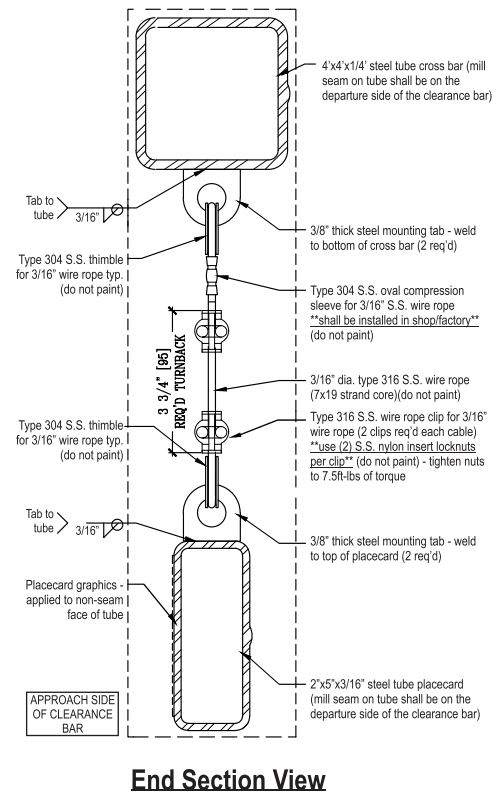

End Section View

Project:



Location:

Client Approval:

Date of Approval:

Sales Rep:

Paul L.

Date:

Drawn by:

L.S.

1		
2		
3		
4		
5		
6		

Electrical Requirement:

120 Volts  277 Volts



2101 Carrillo Privado, Ontario, CA 91761  
(909) 930-0303 Fax: (909) 930-0308  
E-mail: design@signindustries.tv  
Web: www.signindustries.tv

All ideas, plans or arrangements indicated on this drawing are copyrighted and owned by Sign Industries Incorporated and shall not be reproduced, used by or disclosed to any persons, firm or corporation for any purpose whatsoever without written permission of Sign Industries Incorporated.

Drawing No

22-256



Page: 7.0

COLOR LEGEND	
PMS/PAINT	VINYL
PMS 560 C	NA
RAL 7021M	3M 3630-22
REFL. WHITE	3M 680-10

# F CLEARANCE BAR - NON-ILLUMINATED

SBC-#

Qty. 1

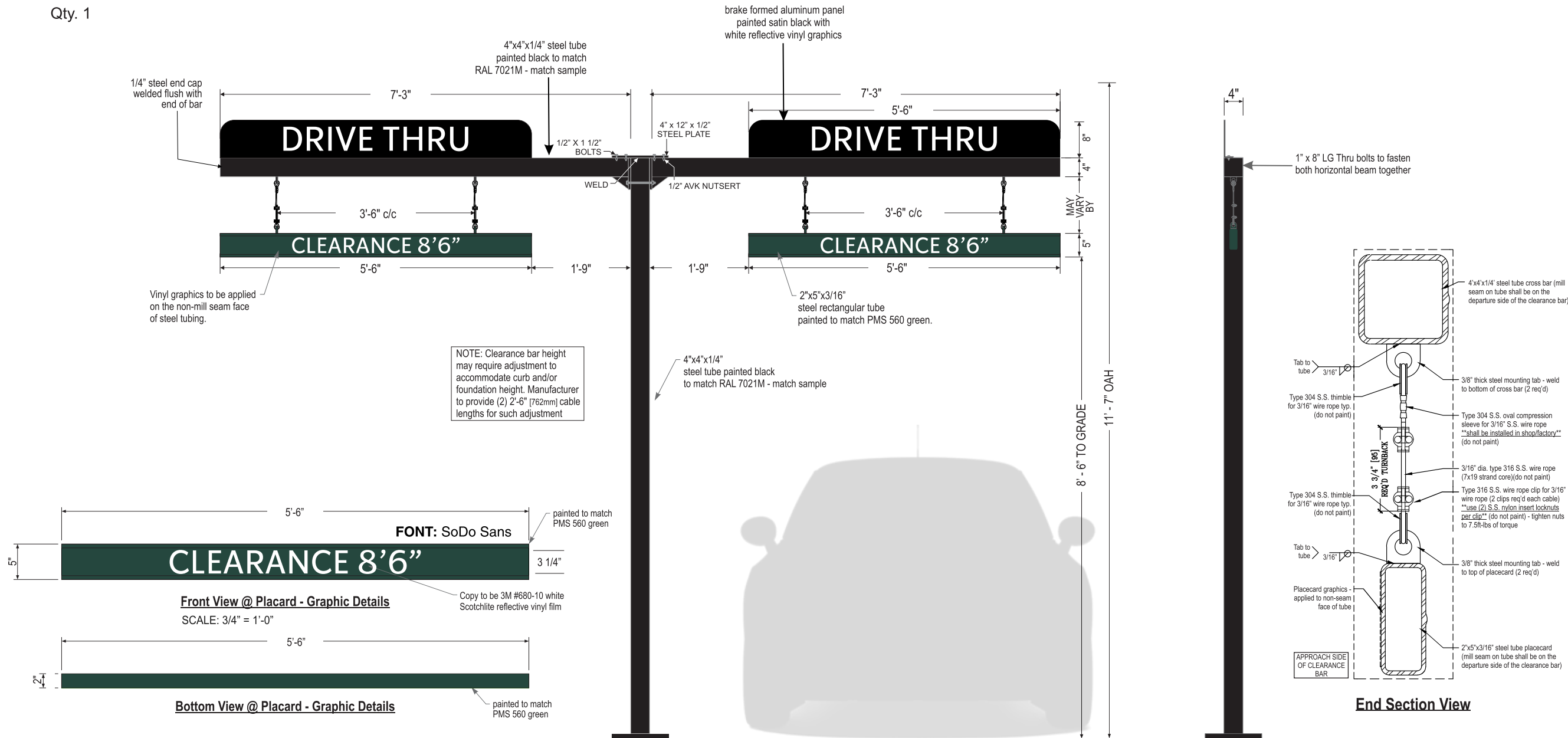

NOTE: Clearance bar height may require adjustment to accommodate curb and/or foundation height. Manufacturer to provide (2) 2'-6" [762mm] cable lengths for such adjustment

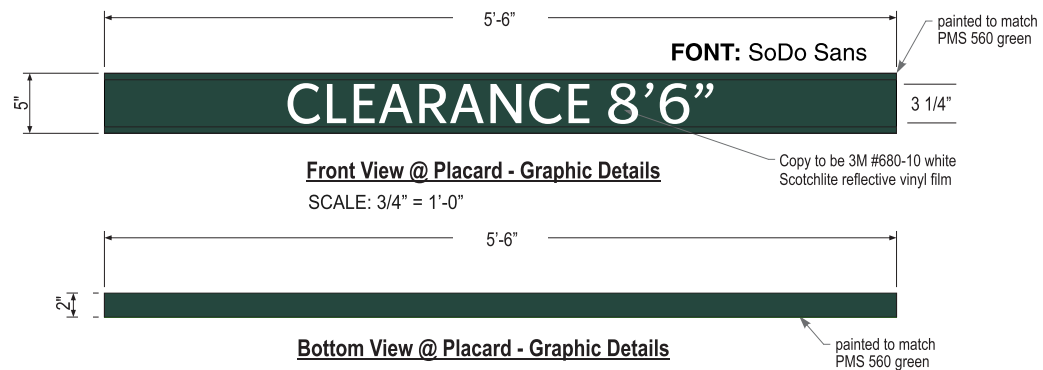

Front Elevation View  
SCALE: 1/2" = 1'-0"

## SIGN SPECIFICATIONS:

- Scraper Bar:**
- 2" x 5'-6" x 5" steel tube painted to match PMS 560 green.
  - Flush steel end caps painted to match PMS 560 green.
  - Copy and chevrons to be 1st surface computer cut 3M #680-10 white Scotchlite reflective vinyl film.
  - Bottom striping to be 1st surface computer cut 3M #680-10 white Scotchlite reflective vinyl film. Striping extends 3/8" [10mm] onto front face.
  - Suspend from support with SS cable & hardware. Cable provided requires field adjustment for proper clearance height.

- DT Panel(s):**
- 8" x 66" brake formed aluminum painted satin black with white reflective vinyl graphics

- Support:**
- Supporting structure will be all welded steel tube construction painted black to match RAL 7021M as per approved shop drawings.
  - New foundation may be required.
  - Clearance bar will be mounted on a concrete pedestal. Will be attached with anchor bolts and base plate (engineering to be confirmed)

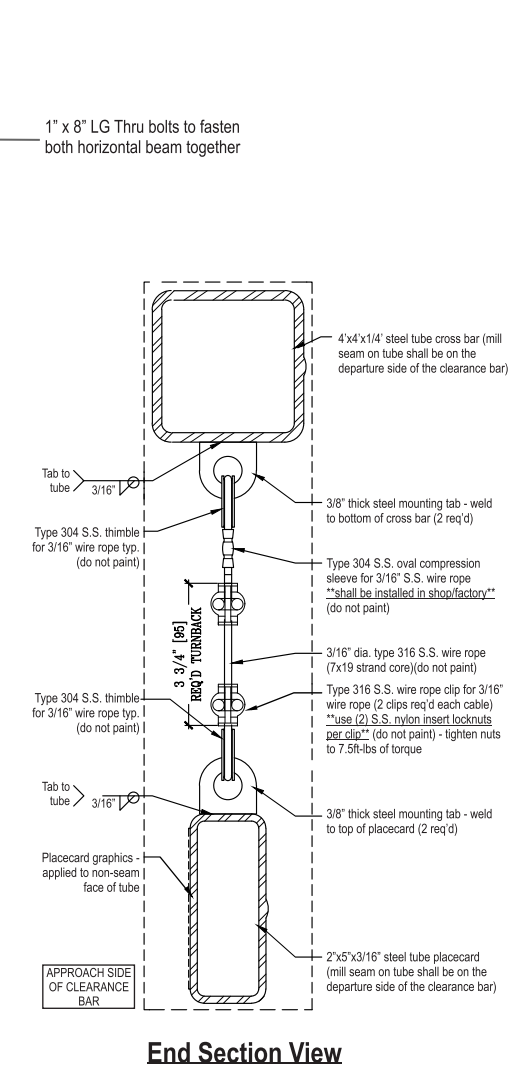

Right Side View

End Section View



Location:

Client Approval:

Date of Approval:

Sales Rep:  
Paul L.

Date: Drawn by:  
L.S.

1		
2		
3		
4		
5		
6		

Electrical Requirement:  
 120 Volts  277 Volts



2101 Carrillo Privado, Ontario, CA 91761  
(909) 930-0303 Fax: (909) 930-0308  
E-mail: design@signindustries.tv  
Web: www.signindustries.tv

All ideas, plans or arrangements indicated on this drawing are copyrighted and owned by Sign Industries Incorporated and shall not be reproduced, used by or disclosed to any persons, firm or corporation for any purpose whatsoever without written permission of Sign Industries Incorporated.

Drawing No  
**22-256**

Page: **7.1**

COLOR LEGEND		
	PMS/PAINT	VINYL
	PMS 560 C	NA
	RAL 7021M	3M 3630-22
	REFL. WHITE	3M 680-10



Location:

Client Approval:

Date of Approval:

Sales Rep:

Paul L.

Date:

Drawn by:

L.S.

1		
2		
3		
4		
5		
6		

Electrical Requirement:

120 Volts  277 Volts



2101 Carrillo Privado, Ontario, CA 91761  
 (909) 930-0303 Fax: (909) 930-0308  
 E-mail: design@signindustries.tv  
 Web: www.signindustries.tv

All ideas, plans or arrangements indicated on this drawing are copyrighted and owned by Sign Industries Incorporated and shall not be reproduced, used by or disclosed to any persons, firm or corporation for any purpose whatsoever without written permission of Sign Industries Incorporated.

Drawing No

22-256



Page: 7.2

**DESIGN CRITERIA:**

- STRUCTURE IS DESIGNED IN ACCORDANCE WITH ASCE 7-16  
 BASIC WIND SPEED: 150 MPH  
 RISK CATEGORY: II  
 EXPOSURE CATEGORY: C  
 SITE CLASS: D  
 OCCUPANCY CATEGORY: II  
 SEISMIC DESIGN CATEGORY: D  
 IMPORTANCE FACTOR: 1.0  
 RESPONSE MODIFICATION FACTOR:  $R_p=3.0$   
 AMPLIFICATION FACTOR:  $A_p=2.5$

**GENERAL NOTES:**

- ALL WORK SHALL BE IN ACCORDANCE WITH THE LATEST EDITIONS OF THE STANDARD SPECIFICATIONS FOR PUBLIC WORKS CONSTRUCTION, THE 2019 CALIFORNIA BUILDING CODE (CBC), AND 2018 INTERNATIONAL BUILDING CODE (IBC).
- ANY CONFLICTS BETWEEN THESE DRAWINGS, STANDARDS NOTED HEREIN, PROJECT REQUIREMENTS, AND/OR OTHER REFERENCE DOCUMENTS SHALL BE BROUGHT TO THE ATTENTION OF THE CIVIL ENGINEER, WHERE CONFLICTS OCCUR, THE MOST STRINGENT REQUIREMENTS SHALL BE FOLLOWED.
- PROVIDE ISOLATION OF DISSIMILAR MATERIALS

**STEEL:**

- SQUARE/REC HSS STEEL: ASTM A500GR. B  $F_y=46$  KSI
- PLATE STEEL: ASTM A36  $F_y=36$  KSI
- STRUCTURAL STEEL MEMBERS SHALL BE SHEARED, FORMED, PUNCHED, WELDED, AND PAINTED BY THE MANUFACTURER. ALL SHOP CONNECTIONS SHALL BE WELDED IN CONFORMANCE WITH STANDARDS BASED UPON THE CURRENT EDITION OF ANSI/AWS D1.1. WELDERS AND WELDING OPERATORS SHALL BE QUALIFIED AS PROVIDED IN THE CODE.

**CONCRETE:**

- DESIGN AND CONSTRUCTION IN COMPLIANCE TO ACI 318-14.
- STEEL REINFORCEMENT IN CONCRETE ASTM A615 GRADE 60.
- COMPRESSIVE STRENGTH AT 28 DAYS:  $f'_c=2500$  PSI MIN.
- PROVIDE A MINIMUM 3" CONCRETE COVER OVER ALL EMBEDDED STEEL.
- CONCRETE MUST BE POURED AGAINST UNDISTURBED EARTH SOIL.
- SOIL PASSIVE PRESSURE PER CBC CLASS 5 (100 PCF).

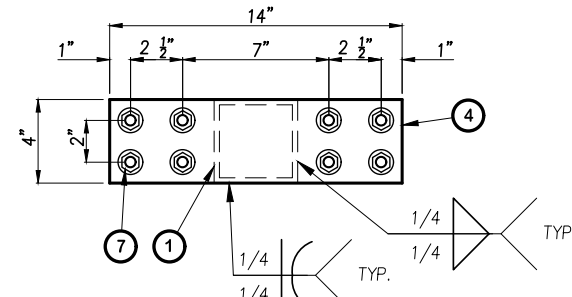
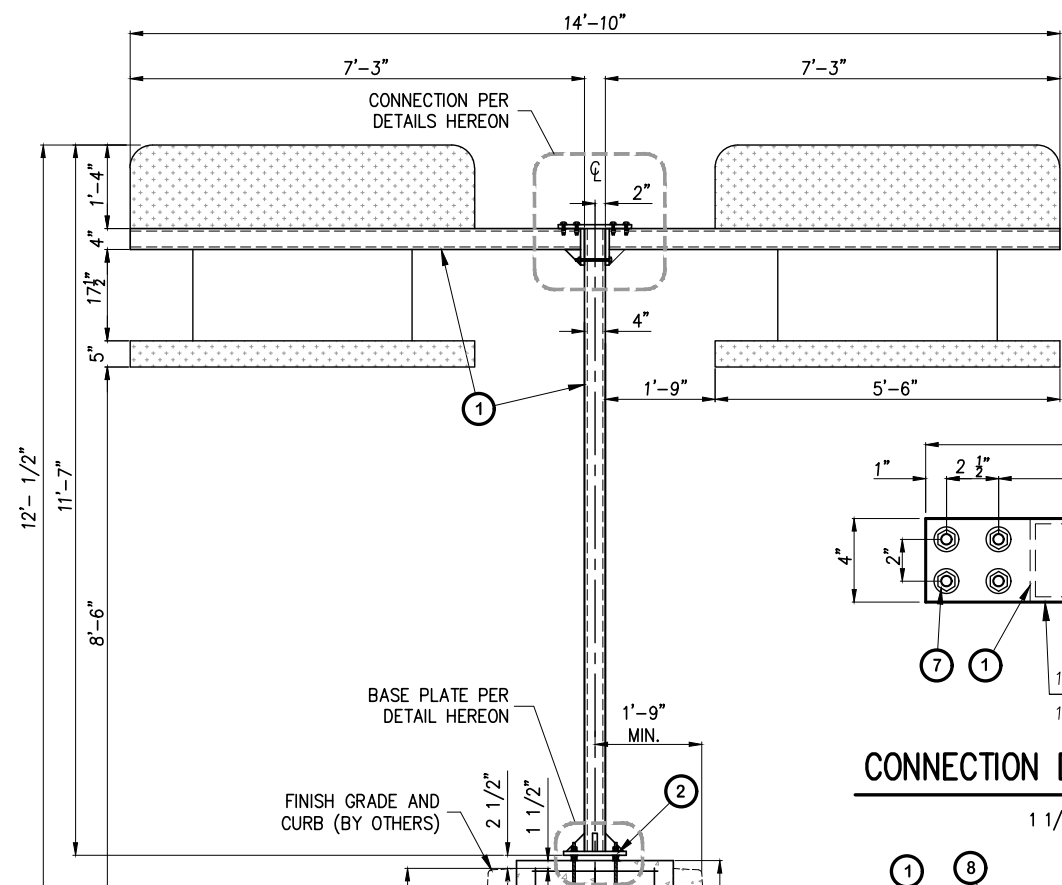

CONNECTION DETAIL (TOP VIEW)

1 1/2" = 1'-0"

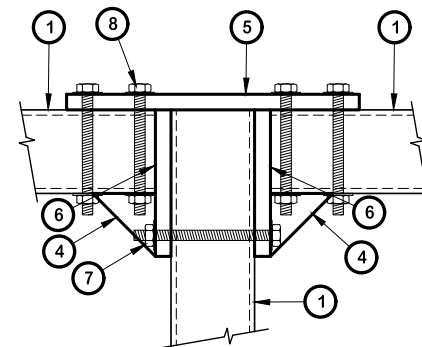

ENLARGEMENT DETAIL

1 1/2" = 1'-0"

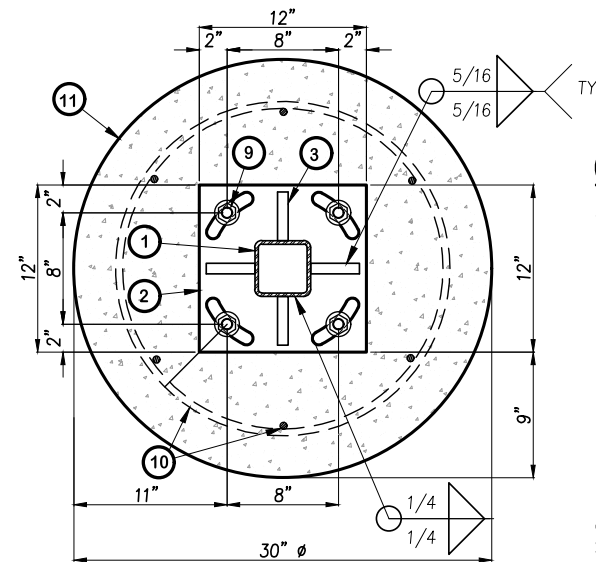

BASE PLATE DETAIL (PLAN VIEW)

1" = 1'-0"

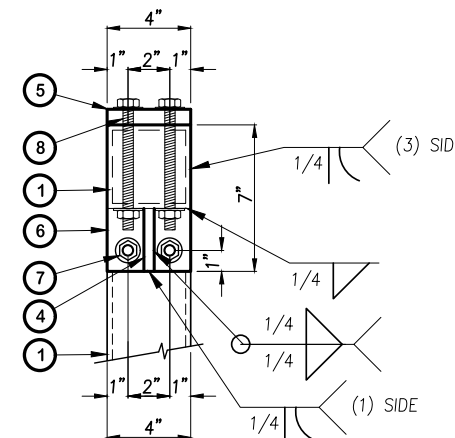

CONNECTION DETAIL (SIDE VIEW)

1 1/2" = 1'-0"

- 4" x 4" x 1/4" SQ. HSS FRAME PER ELEVATION AND BASE PLATE DETAILS HEREON.
- 1" THK. STEEL BASE PLATE (12"x12") PER BASE PLATE DETAIL HEREON.
- (4) 3 1/2" x 3 1/2" x 3/4" STEEL GUSSET PLATE PER BASE PLATE DETAIL HEREON.
- (2) 3" x 3" x 1/2" STEEL GUSSET PLATE PER DETAILS HEREON.
- 3/4" THK. MOUNTING PLATE (14"x4") PER DETAILS HEREON.
- 3/4" THK. BASE PLATE (7"x4") PER DETAILS HEREON.
- (2) 1/2" HDG THRU BOLT PER ASTM A325 WITH HEAVY HEX HEAD HARDWARE PER DETAILS HEREON.
- (8) 1/2" HDG THRU BOLT PER ASTM A325 WITH HEAVY HEX HEAD HARDWARE PER DETAILS HEREON.
- (4) 5/8" THREADED HOT DIPPED GALVANIZED HEAVY HEX BOLT (ASTM F1554 GRADE 55) WITH GALVANIZED HARDWARE PER ELEVATION AND BASE PLATE DETAIL HEREON.
- HORIZ: (3) #4 TIES AT 5" O.C. TOP  
 (3) #4 TIES AT 6" O.C. TOP 30"  
 (3) #4 TIES AT 12" O.C. REMAINDER  
 VERT: (6) #6 BARS SPACES EVENLY AROUND PERIMETER CLEARANCE 3" MIN. TO EDGE OF CONC.
- CONCRETE FOOTING PER PLAN AND SPECIFICATIONS HEREON.



PREPARED BY:

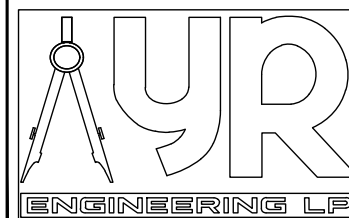

YR ENGINEERING LP  
 424 E. MAITLAND ST. STE. A  
 ONTARIO, CA 91761  
 PHONE: (626) 374-5881  
 EMAIL: YRAMOS@YRENGINEERING.COM

STARBUCKS DRIVE THRU SIGNAGE  
 CLEARANCE BAR DETAILS  
 VARIOUS LOCATIONS, CALIFORNIA

PREPARED FOR: SIGN INDUSTRIES, INC.

CHECKED BY: YR	JOB NO: 2204-00	SHEET: 1 OF 2
DISREGARD PRINTS BEARING EARLIER REVISION DATES →	02-24-22	

# F CLEARANCE BAR - ILLUMINATED

SBC-#

Qty. 1

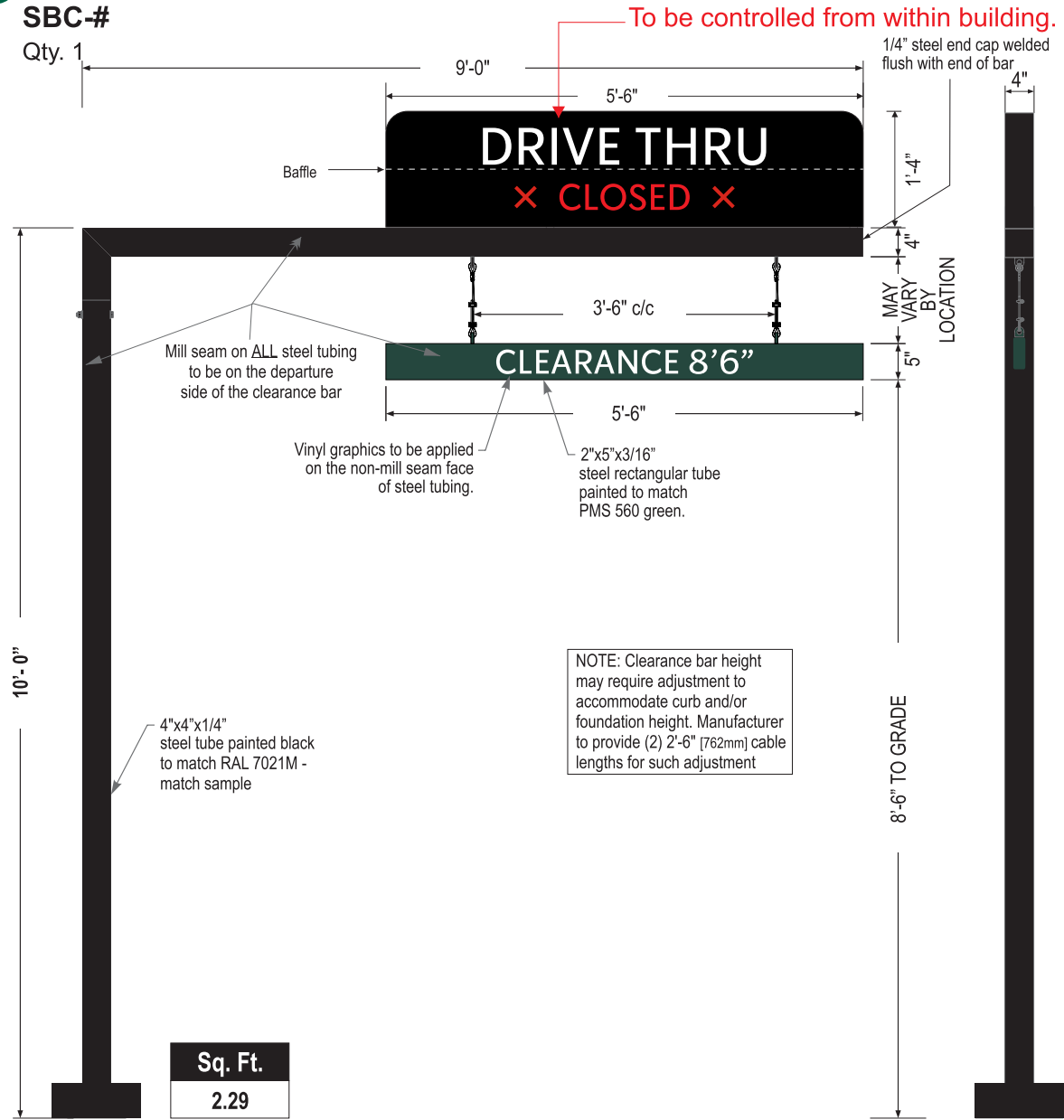

NOTE: Clearance bar height may require adjustment to accommodate curb and/or foundation height. Manufacturer to provide (2) 2'-6" [762mm] cable lengths for such adjustment

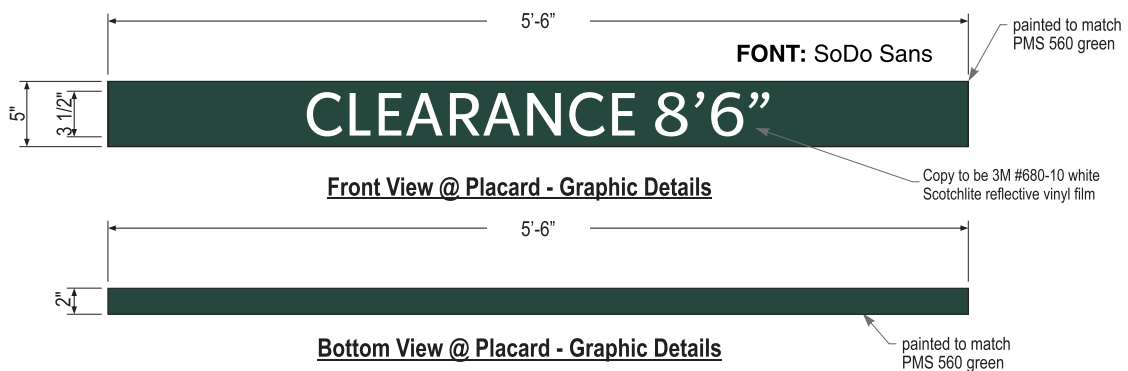

COLOR LEGEND	
PMS/PAINT	VINYL
PMS 560 C	NA
RAL 7021M	3M 3630-22
REFL. WHITE	3M 680-10

Note: GC responsible for placing qty. one (1) 3 position switch inside of the building adjacent to the pick up window and responsible for running the 4 switch controlled circuits to the clearance bar footer when footer is poured.

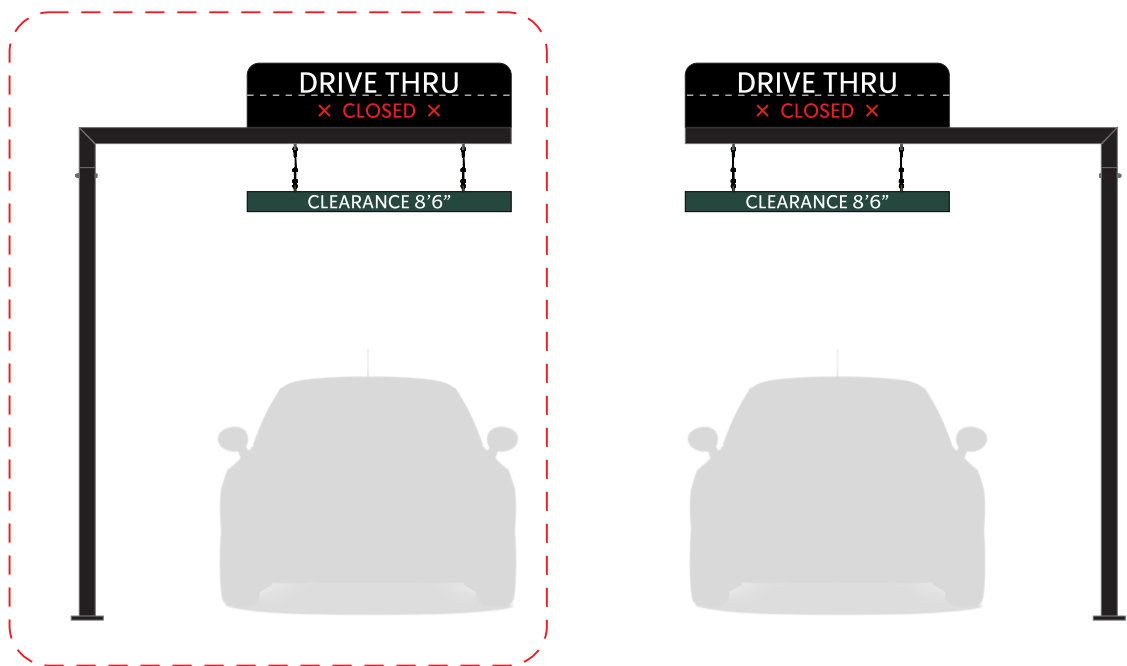

## SIGN SPECIFICATIONS:

### Scraper Bar:

- 2" x 5'-6" x 5" steel tube painted to match PMS 560 green.
- Flush steel end caps painted to match PMS 560 green.
- Copy and chevrons to be 1st surface computer cut 3M #680-10 white Scotchlite reflective vinyl film.
- Bottom striping to be 1st surface computer cut 3M #680-10 white Scotchlite reflective vinyl film. Striping extends 3/8" [10mm] onto front face.
- Suspend from support with SS cable & hardware. Cable provided requires field adjustment for proper clearance height.

### DT Cabinet:

- 16" x 66" x 4" w/ 3" Radius Top Corners Fabricated .090" [2mm] aluminum housing painted black to match RAL 7021M
- Drive Thru copy backed up with .125" white polycarb. All polycarb face elements to be attached to aluminum face panel with weld studs.
- "OPEN" / "CLOSE" Digital LED units
- Welded aluminum construction with no visible fasteners.
- All fasteners used in the assembly of internal components shall be coated to prevent corrosion. Internal structure of cabinet shall be per approved shop drawings.
- Graphic elements are internally illuminated using Sloan Prism Enlighten LEDs. LED's to be mounted on back of cabinet with self-contained power supply. All electrical components are removable for service.

### Support:

- Supporting structure will be all welded steel tube construction painted black to match RAL 7021M as per approved shop drawings.
- New foundation may be required.
- Clearance bar will be mounted on a concrete pedestal. Will be attached with anchor bolts and base plate (engineering to be confirmed)

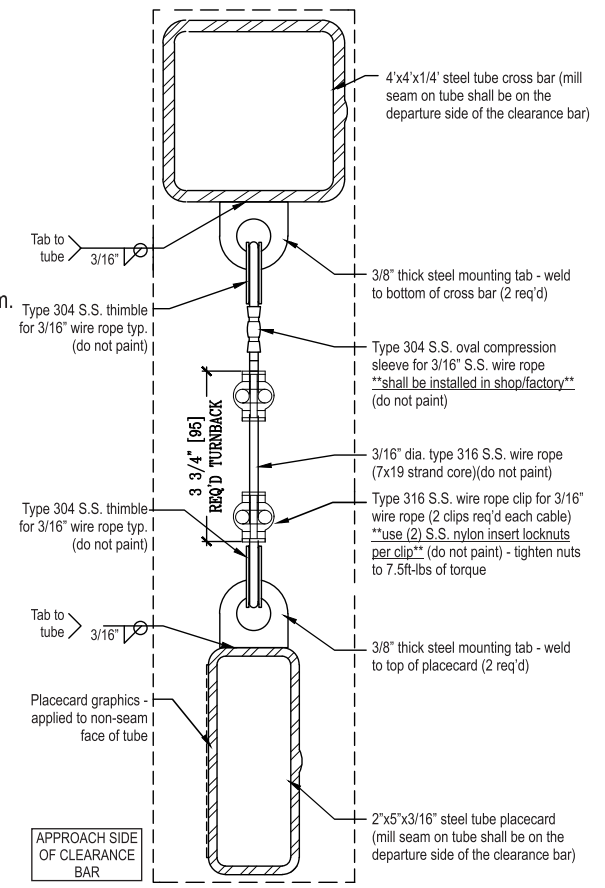

End Section View

Project:



Location:

Client Approval:

Date of Approval:

Sales Rep:

Paul L.

Date:

Drawn by:

L.S.

1		
2		
3		
4		
5		
6		

Electrical Requirement:

120 Volts

277 Volts



2101 Carrillo Privado, Ontario, CA 91761  
 (909) 930-0303 Fax: (909) 930-0308  
 E-mail: design@signindustries.tv  
 Web: www.signindustries.tv

All ideas, plans or arrangements indicated on this drawing are copyrighted and owned by Sign Industries Incorporated and shall not be reproduced, used by or disclosed to any persons, firm or corporation for any purpose whatsoever without written permission of Sign Industries Incorporated.

Drawing No

22-256



Page: 7.3

# F CLEARANCE BAR - NON-ILLUMINATED

SBC-#

Qty. 1

**Note: GC responsible for placing qty. one (1) 3 position switch inside of the building adjacent to the pick up window and responsible for running the 4 switch controlled circuits to the clearance bar footer when footer is poured.**

Project:



Location:

Client Approval:

Date of Approval:

Sales Rep:

Paul L.

Date:

Drawn by:

L.S.

1		
2		
3		
4		
5		
6		

Electrical Requirement:

120 Volts

277 Volts



2101 Carrillo Privado, Ontario, CA 91761  
 (909) 930-0303 Fax: (909) 930-0308  
 E-mail: design@signindustries.tv  
 Web: www.signindustries.tv

All ideas, plans or arrangements indicated on this drawing are copyrighted and owned by Sign Industries Incorporated and shall not be reproduced, used by or disclosed to any persons, firm or corporation for any purpose whatsoever without written permission of Sign Industries Incorporated.

Drawing No

22-256



Page: 7.4

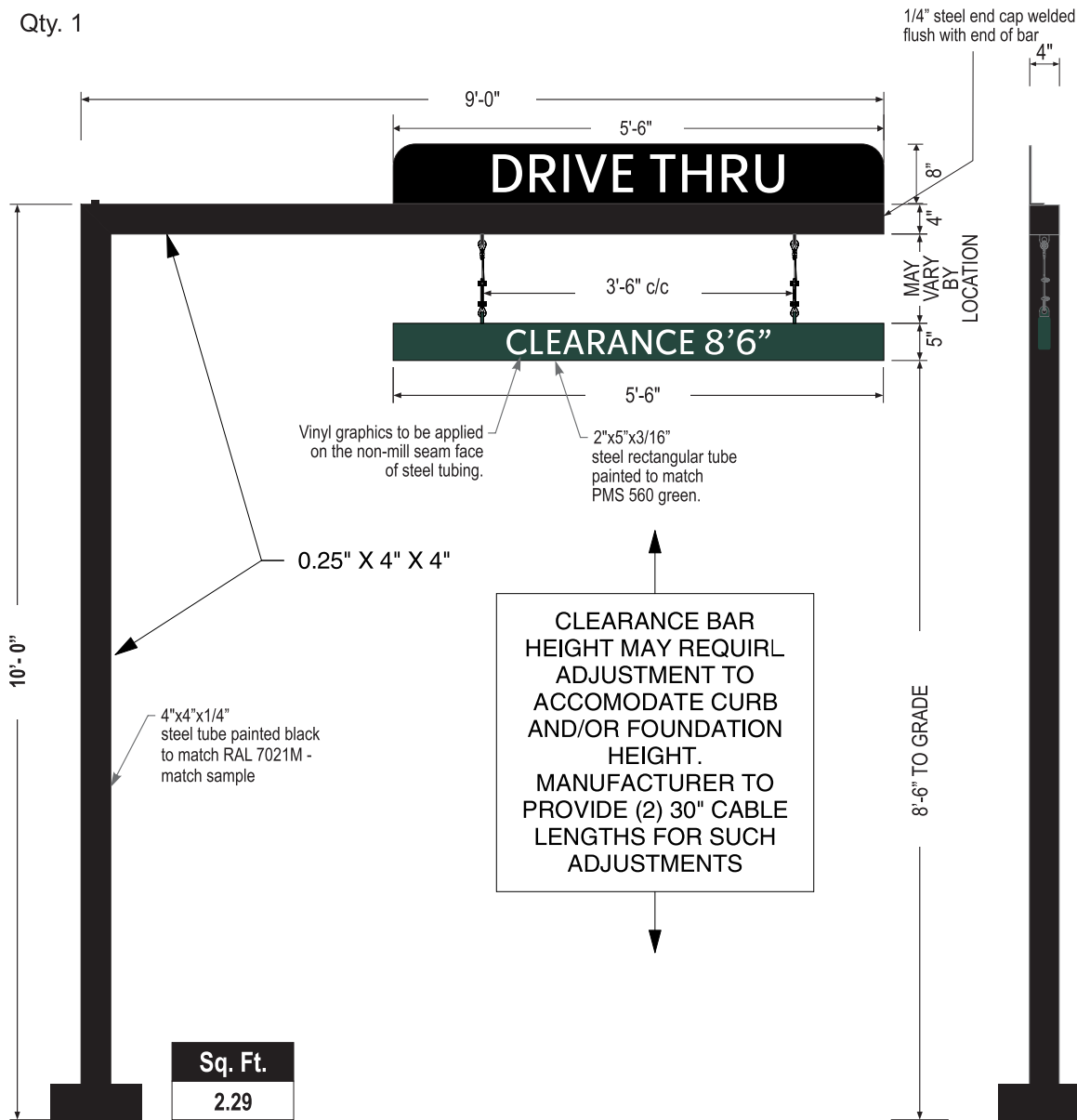

CLEARANCE BAR HEIGHT MAY REQUIRL ADJUSTMENT TO ACCOMODATE CURB AND/OR FOUNDATION HEIGHT. MANUFACTURER TO PROVIDE (2) 30" CABLE LENGTHS FOR SUCH ADJUSTMENTS

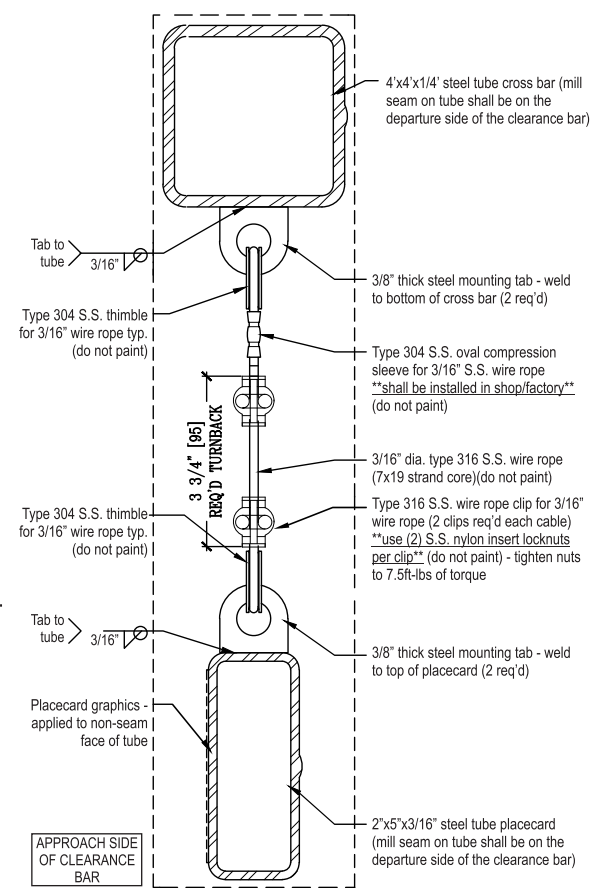
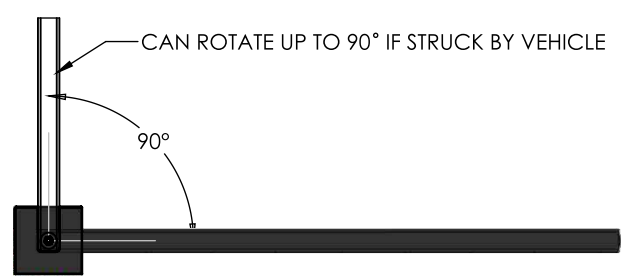
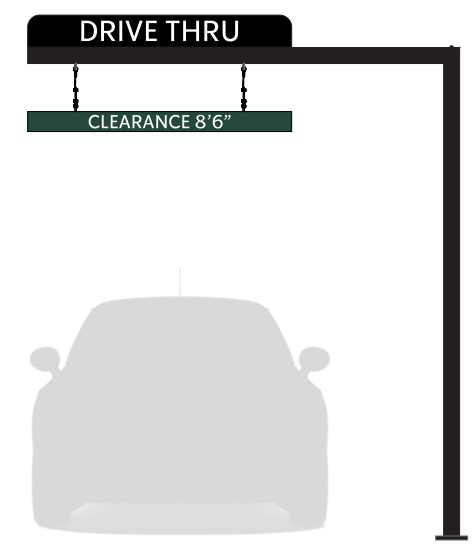
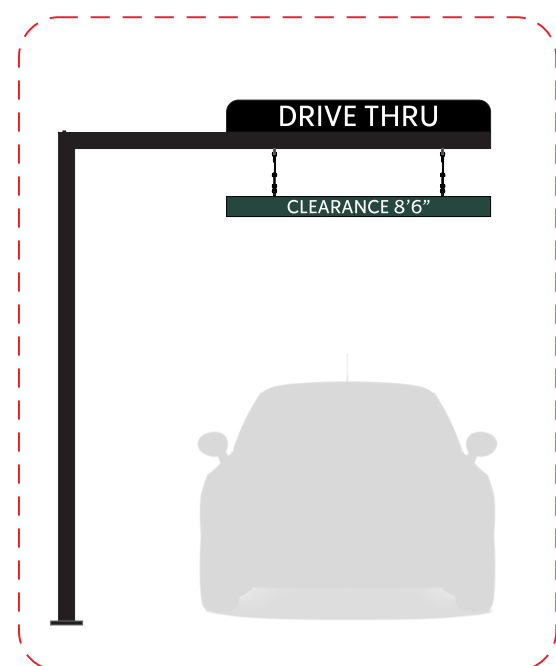

End Section View

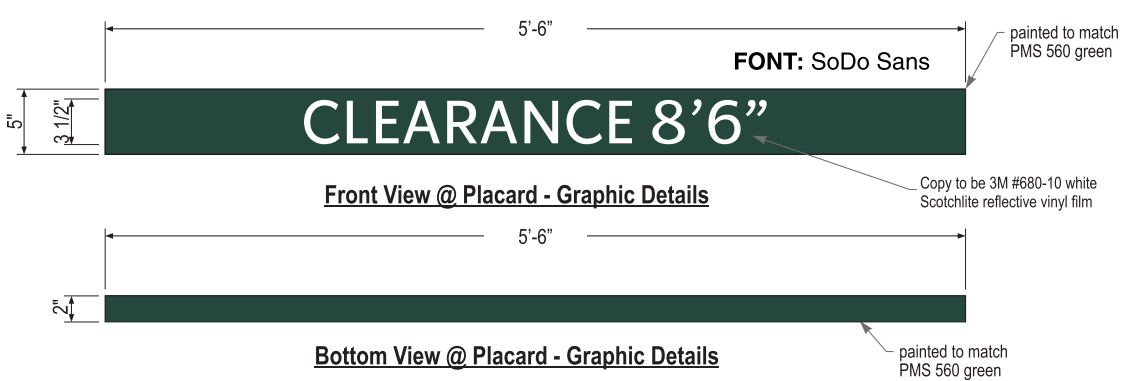

### SIGN SPECIFICATIONS:

#### Scraper Bar:

- 2" x 5'-6" x 5" steel tube painted to match PMS 560 green.
- Flush steel end caps painted to match PMS 560 green.
- Copy and chevrons to be 1st surface computer cut 3M #680-10 white Scotchlite reflective vinyl film.
- Bottom striping to be 1st surface computer cut 3M #680-10 white Scotchlite reflective vinyl film. Striping extends 3/8" [10mm] onto front face.
- Suspend from support with SS cable & hardware. Cable provided requires field adjustment for proper clearance height.

#### DT Panel:

- 8" x 66" brake formed aluminum painted satin black with white reflective vinyl graphics

#### Support:

- Supporting structure will be all welded steel tube construction painted black to match RAL 7021M as per approved shop drawings.
- New foundation may be required.
- Clearance bar will be mounted on a concrete pedestal. Will be attached with anchor bolts and base plate (engineering to be confirmed)

COLOR LEGEND		
	PMS/PAINT	VINYL
	PMS 560 C	NA
	RAL 7021M	3M 3630-22
	REFL. WHITE	3M 680-10

# F CLEARANCE BAR - ILLUMINATED

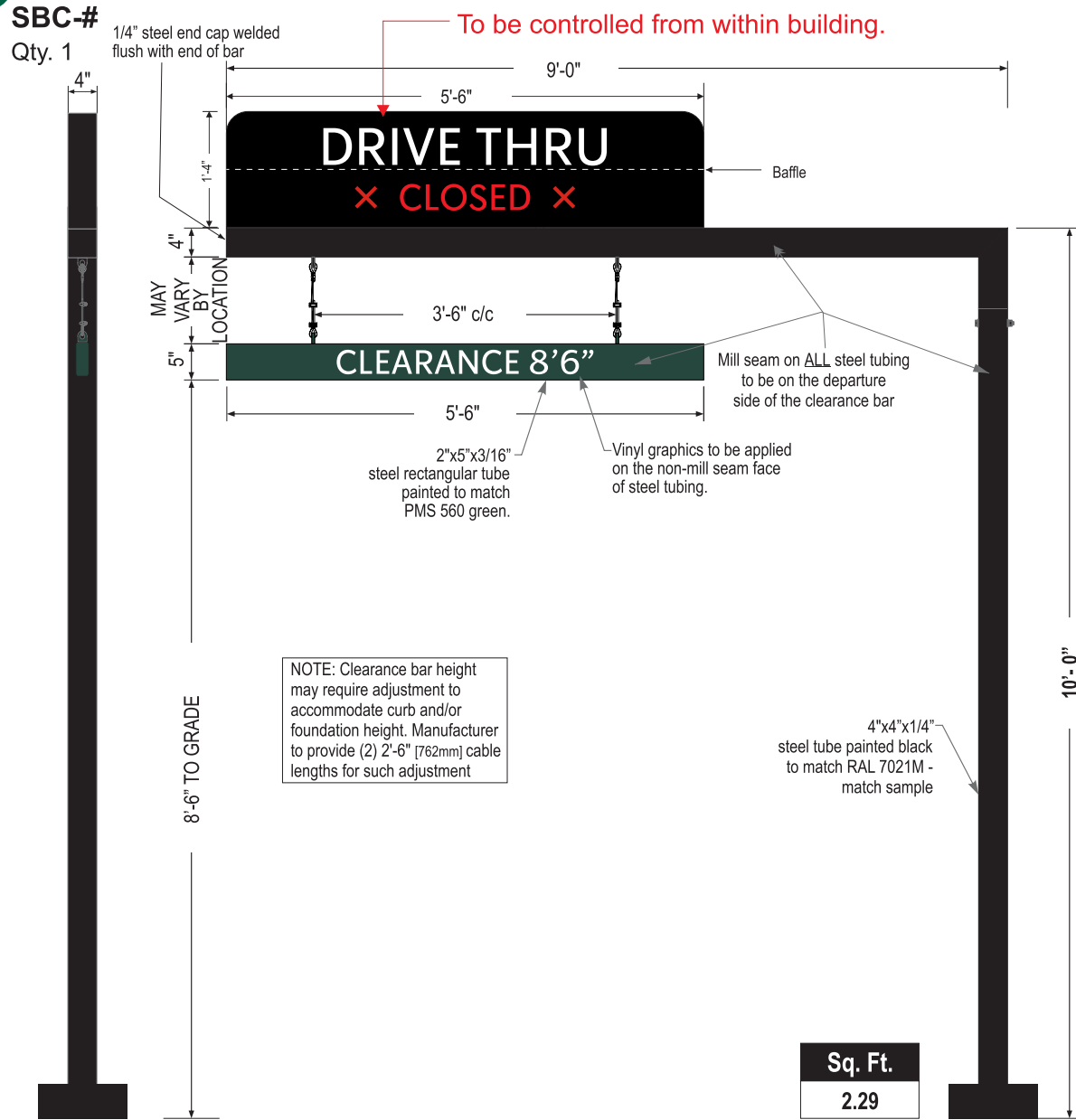

NOTE: Clearance bar height may require adjustment to accommodate curb and/or foundation height. Manufacturer to provide (2) 2'-6" [762mm] cable lengths for such adjustment

Sq. Ft.  
2.29

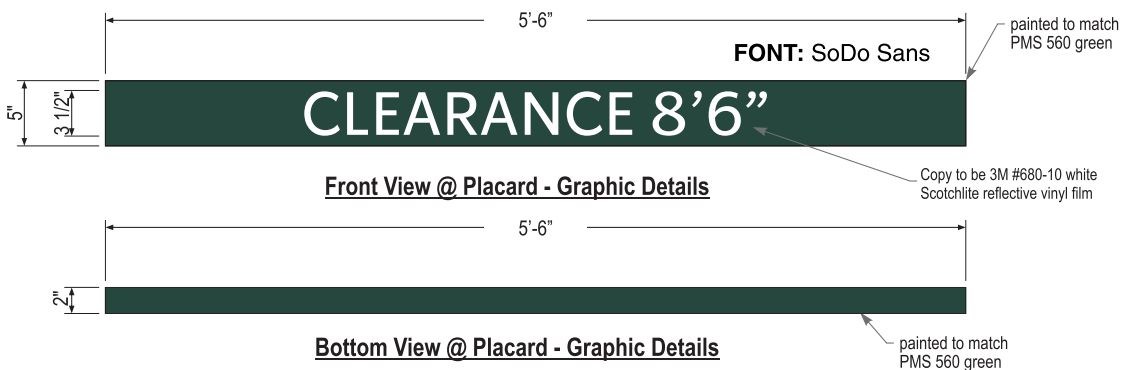

COLOR LEGEND	
PMS/PAIN	VINYL
PMS 560 C	NA
RAL 7021M	3M 3630-22
REFL. WHITE	3M 680-10

Note: GC responsible for placing qty. one (1) 3 position switch inside of the building adjacent to the pick up window and responsible for running the 4 switch controlled circuits to the clearance bar footer when footer is poured.

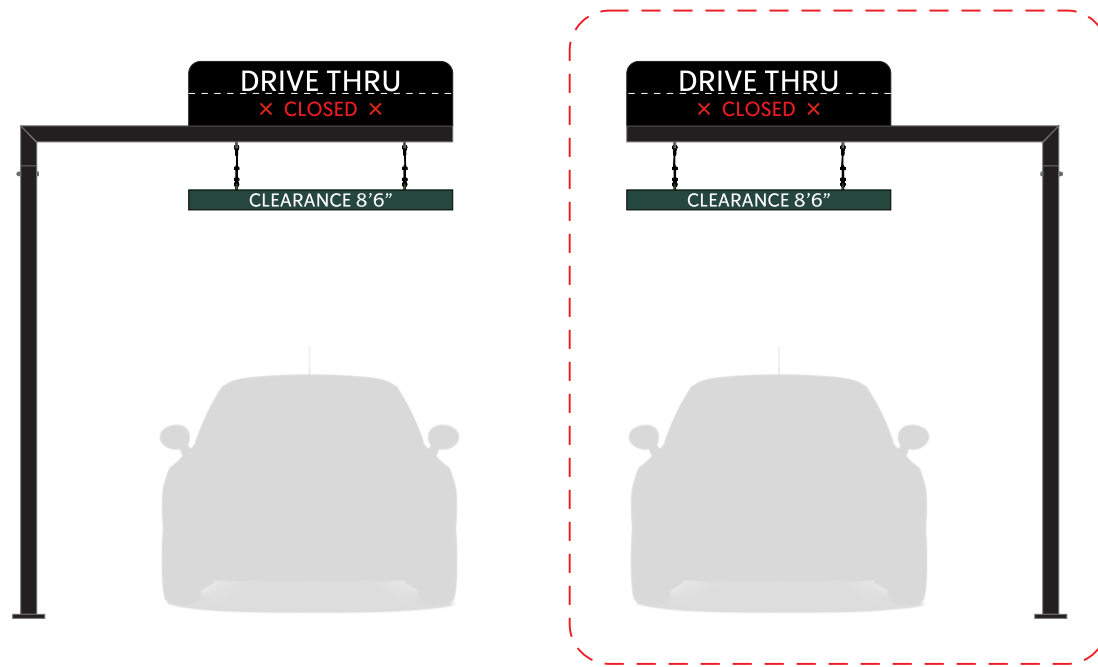

## SIGN SPECIFICATIONS:

### Scraper Bar:

- 2" x 5'-6" x 5" steel tube painted to match PMS 560 green.
- Flush steel end caps painted to match PMS 560 green.
- Copy and chevrons to be 1st surface computer cut 3M #680-10 white Scotchlite reflective vinyl film.
- Bottom striping to be 1st surface computer cut 3M #680-10 white Scotchlite reflective vinyl film. Striping extends 3/8" [10mm] onto front face.
- Suspend from support with SS cable & hardware. Cable provided requires field adjustment for proper clearance height.

### DT Cabinet:

- 16" x 66" x 4" w/ 3" Radius Top Corners Fabricated .090" [2mm] aluminum housing painted black to match RAL 7021M
- Drive Thru copy backed up with .125" white polycarb. All polycarb face elements to be attached to aluminum face panel with weld studs.
- "OPEN" / "CLOSE" Digital LED units
- Welded aluminum construction with no visible fasteners.
- All fasteners used in the assembly of internal components shall be coated to prevent corrosion. Internal structure of cabinet shall be per approved shop drawings.
- Graphic elements are internally illuminated using Sloan Prism Enlighten LEDs. LED's to be mounted on back of cabinet with self-contained power supply. All electrical components are removable for service.

### Support:

- Supporting structure will be all welded steel tube construction painted black to match RAL 7021M as per approved shop drawings.
- New foundation may be required.
- Clearance bar will be mounted on a concrete pedestal. Will be attached with anchor bolts and base plate (engineering to be confirmed)

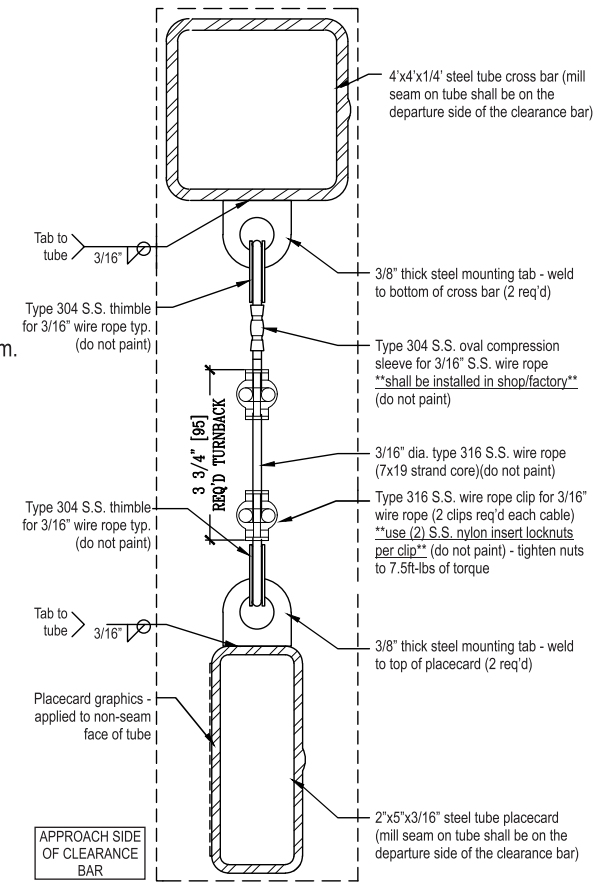

End Section View

Project:



Location:

Client Approval:

Date of Approval:

Sales Rep:

Paul L.

Date:

Drawn by:

L.S.

1		
2		
3		
4		
5		
6		

Electrical Requirement:

120 Volts

277 Volts



2101 Carrillo Privado, Ontario, CA 91761  
(909) 930-0303 Fax: (909) 930-0308  
E-mail: design@signindustries.tv  
Web: www.signindustries.tv

All ideas, plans or arrangements indicated on this drawing are copyrighted and owned by Sign Industries Incorporated and shall not be reproduced, used by or disclosed to any persons, firm or corporation for any purpose whatsoever without written permission of Sign Industries Incorporated.

Drawing No

22-256



Page: 7.5

# F CLEARANCE BAR - NON-ILLUMINATED

SBC-#

Qty. 1

**Note: GC responsible for placing qty. one (1) 3 position switch inside of the building adjacent to the pick up window and responsible for running the 4 switch controlled circuits to the clearance bar footer when footer is poured.**

Project:



Location:

Client Approval:

Date of Approval:

Sales Rep:

Paul L.

Date:

Drawn by:

L.S.

1		
2		
3		
4		
5		
6		

Electrical Requirement:

120 Volts

277 Volts



2101 Carrillo Privado, Ontario, CA 91761  
(909) 930-0303 Fax: (909) 930-0308  
E-mail: design@signindustries.tv  
Web: www.signindustries.tv

All ideas, plans or arrangements indicated on this drawing are copyrighted and owned by Sign Industries Incorporated and shall not be reproduced, used by or disclosed to any persons, firm or corporation for any purpose whatsoever without written permission of Sign Industries Incorporated.

Drawing No

22-256



Page: 7.6

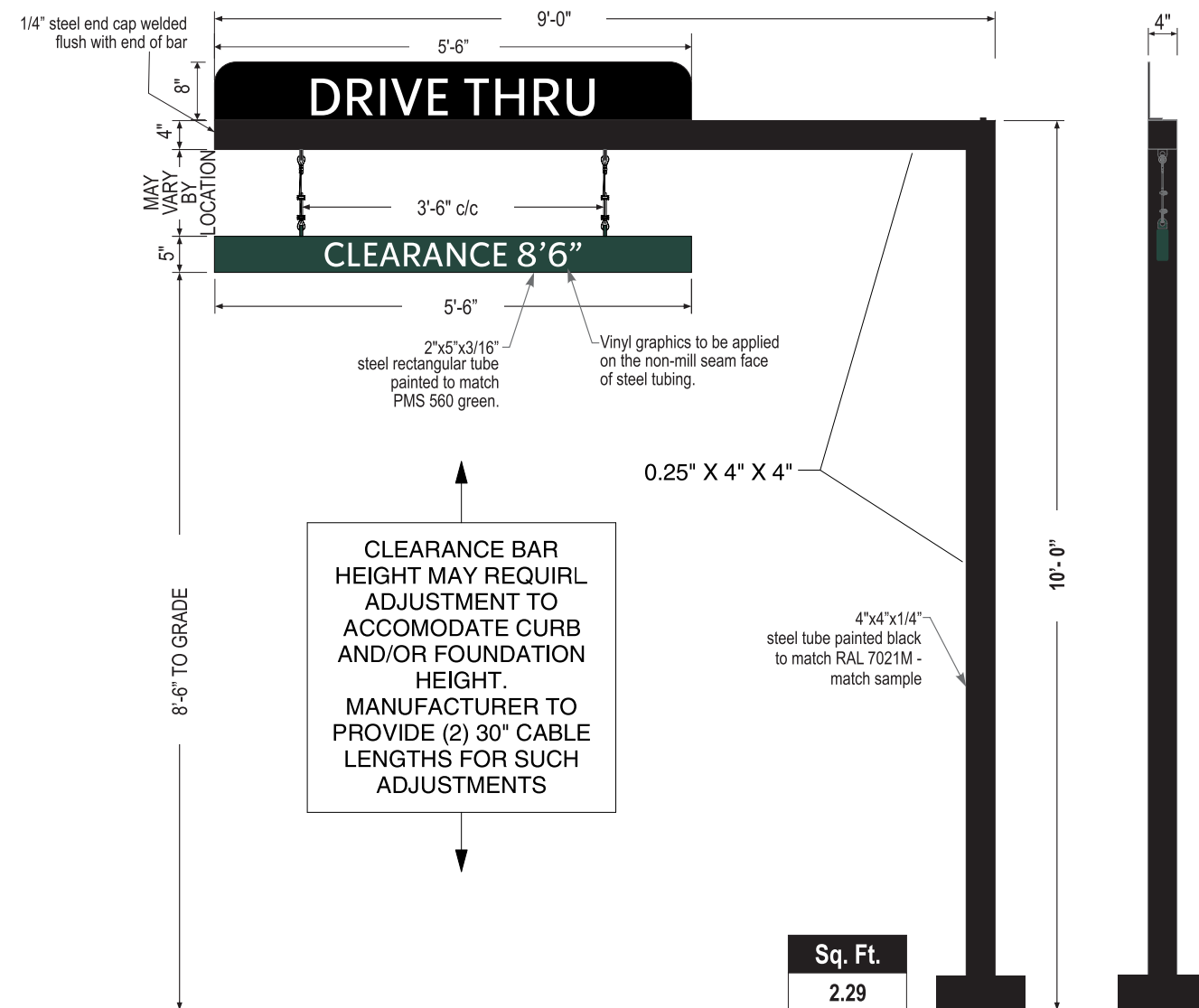

CLEARANCE BAR HEIGHT MAY REQUIR L ADJUSTMENT TO ACCOMODATE CURB AND/OR FOUNDATION HEIGHT. MANUFACTURER TO PROVIDE (2) 30" CABLE LENGTHS FOR SUCH ADJUSTMENTS

Sq. Ft.  
2.29

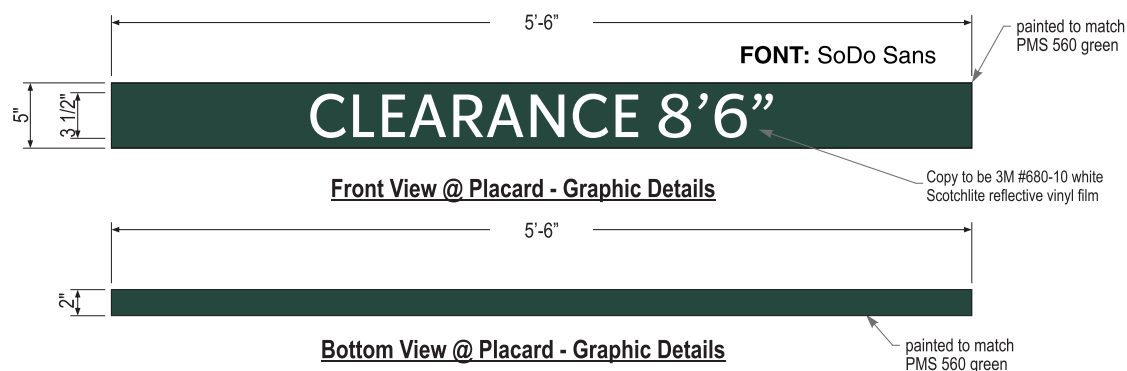

### SIGN SPECIFICATIONS:

#### Scraper Bar:

- 2" x 5'-6" x 5" steel tube painted to match PMS 560 green.
- Flush steel end caps painted to match PMS 560 green.
- Copy and chevrons to be 1st surface computer cut 3M #680-10 white Scotchlite reflective vinyl film.
- Bottom striping to be 1st surface computer cut 3M #680-10 white Scotchlite reflective vinyl film. Striping extends 3/8" [10mm] onto front face.
- Suspend from support with SS cable & hardware. Cable provided requires field adjustment for proper clearance height.

#### DT Panel:

- 8" x 66" brake formed aluminum painted satin black with white reflective vinyl graphics

#### Support:

- Supporting structure will be all welded steel tube construction painted black to match RAL 7021M as per approved shop drawings.
- New foundation may be required.
- Clearance bar will be mounted on a concrete pedestal. Will be attached with anchor bolts and base plate (engineering to be confirmed)

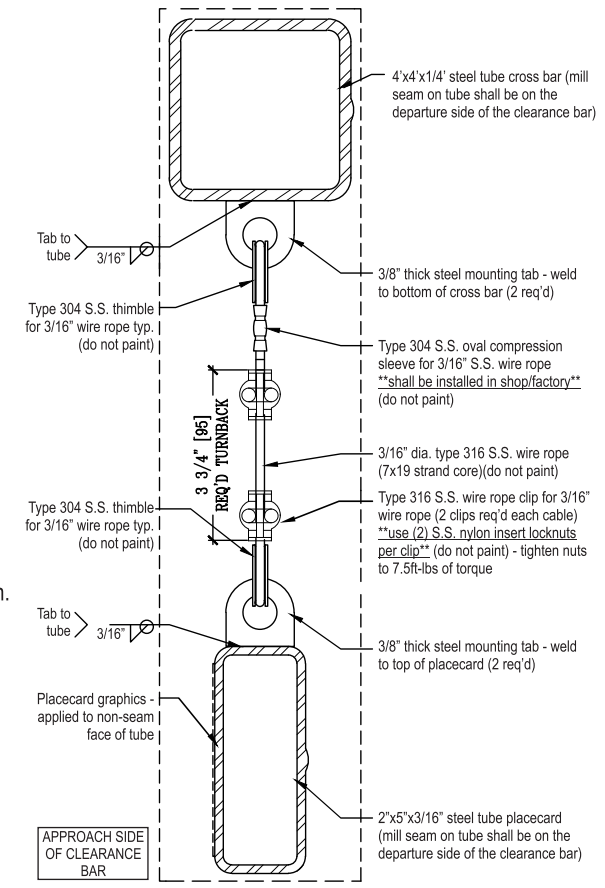
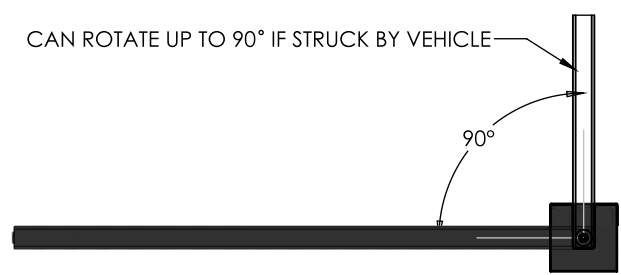
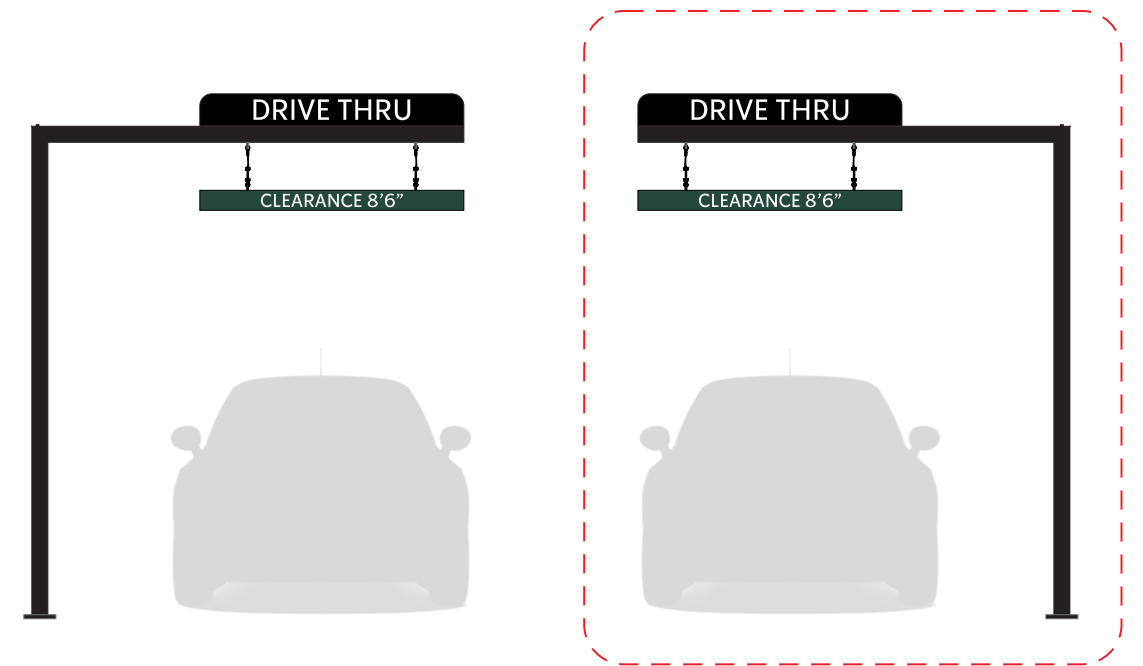

End Section View

COLOR LEGEND		
	PMS/PAINT	VINYL
	PMS 560 C	NA
	RAL 7021M	3M 3630-22
	REFL. WHITE	3M 680-10



1		
2		
3		
4		
5		
6		



2101 Carrillo Privado, Ontario, CA 91761  
 (909) 930-0303 Fax: (909) 930-0308  
 E-mail: design@signindustries.tv  
 Web: www.signindustries.tv

All ideas, plans or arrangements indicated on this drawing are copyrighted and owned by Sign Industries Incorporated and shall not be reproduced, used by or disclosed to any persons, firm or corporation for any purpose whatsoever without written permission of Sign Industries Incorporated.

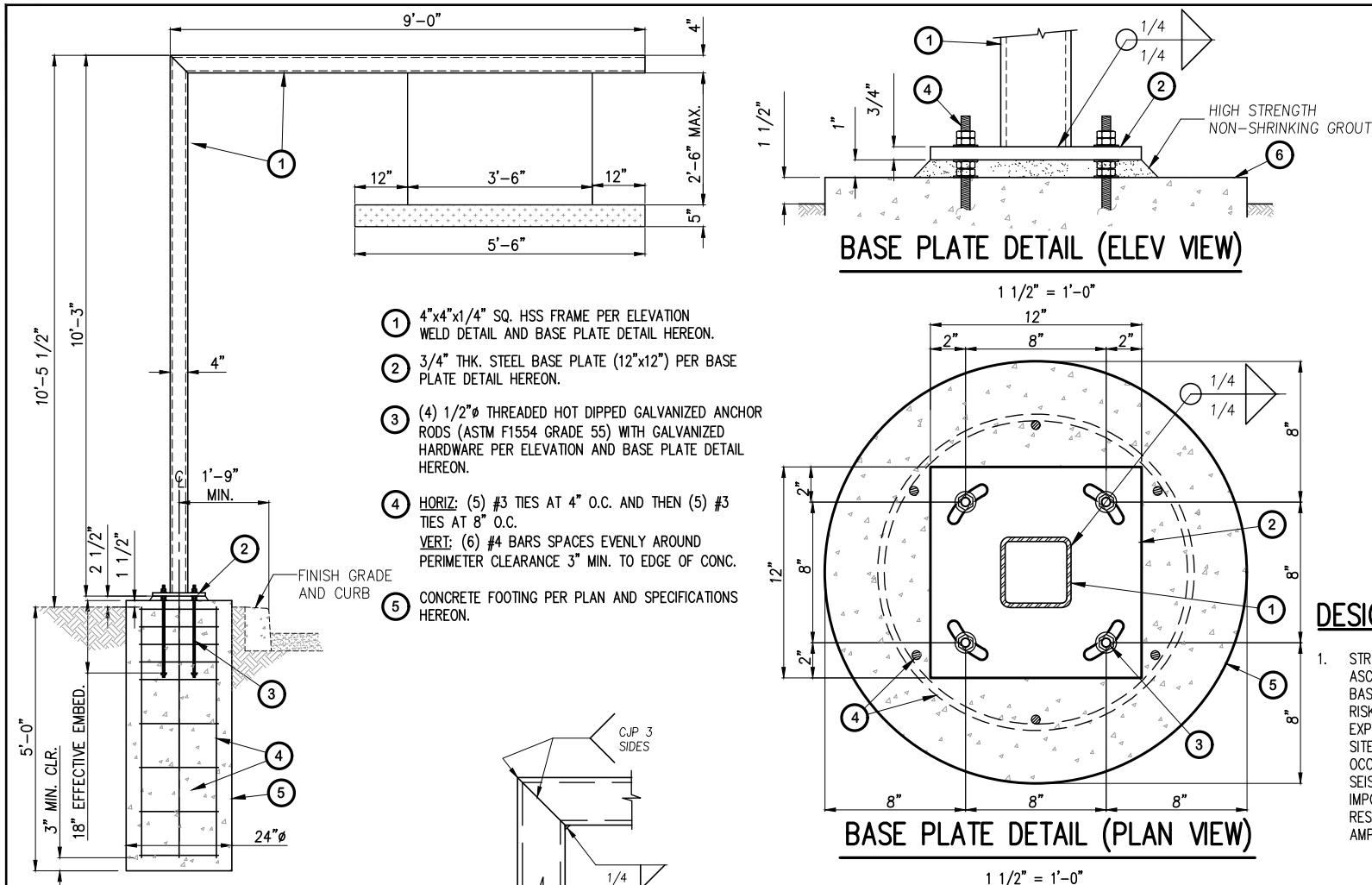

- 1 4"x4"x1/4" SQ. HSS FRAME PER ELEVATION WELD DETAIL AND BASE PLATE DETAIL HEREON.
- 2 3/4" THK. STEEL BASE PLATE (12"x12") PER BASE PLATE DETAIL HEREON.
- 3 (4) 1/2"Ø THREADED HOT DIPPED GALVANIZED ANCHOR RODS (ASTM F1554 GRADE 55) WITH GALVANIZED HARDWARE PER ELEVATION AND BASE PLATE DETAIL HEREON.
- 4 HORIZ: (5) #3 TIES AT 4" O.C. AND THEN (5) #3 TIES AT 8" O.C.  
 VERT: (6) #4 BARS SPACES EVENLY AROUND PERIMETER CLEARANCE 3" MIN. TO EDGE OF CONC.
- 5 CONCRETE FOOTING PER PLAN AND SPECIFICATIONS HEREON.

- STEEL:**
- SQUARE/REC HSS STEEL: ASTM A500GR. B Fy=46 KSI
  - PLATE STEEL: ASTM A36 Fy=36 KSI
  - STRUCTURAL STEEL MEMBERS SHALL BE SHEARED, FORMED, PUNCHED, WELDED, AND PAINTED BY THE MANUFACTURER. ALL SHOP CONNECTIONS SHALL BE WELDED IN CONFORMANCE WITH STANDARDS BASED UPON THE CURRENT EDITION OF ANSI/AWS D1.1. WELDERS AND WELDING OPERATORS SHALL BE QUALIFIED AS PROVIDED IN THE CODE.

**GENERAL NOTES:**

- ALL WORK SHALL BE IN ACCORDANCE WITH THE LATEST EDITIONS OF THE STANDARD SPECIFICATIONS FOR PUBLIC WORKS CONSTRUCTION, THE 2019 CALIFORNIA BUILDING CODE (CBC), AND 2018 INTERNATIONAL BUILDING CODE (IBC).
- ANY CONFLICTS BETWEEN THESE DRAWINGS, STANDARDS NOTED HEREIN, PROJECT REQUIREMENTS, AND/OR OTHER REFERENCE DOCUMENTS SHALL BE BROUGHT TO THE ATTENTION OF THE CIVIL ENGINEER, WHERE CONFLICTS OCCUR, THE MOST STRINGENT REQUIREMENTS SHALL BE FOLLOWED.
- PROVIDE ISOLATION OF DISSIMILAR MATERIALS

**DESIGN CRITERIA:**

- STRUCTURE IS DESIGNED IN ACCORDANCE WITH ASCE 7-16  
 BASIC WIND SPEED: 150 MPH  
 RISK CATEGORY: II  
 EXPOSURE CATEGORY: C  
 SITE CLASS: D  
 OCCUPANCY CATEGORY: II  
 SEISMIC DESIGN CATEGORY: D  
 IMPORTANCE FACTOR: 1.0  
 RESPONSE MODIFICATION FACTOR: Rp=3.0  
 AMPLIFICATION FACTOR: Ap=3.0

**CONCRETE:**

- DESIGN AND CONSTRUCTION IN COMPLIANCE TO ACI 318-14.
- STEEL REINFORCEMENT IN CONCRETE ASTM A615 GRADE 60.
- COMPRESSIVE STRENGTH AT 28 DAYS: f'c=2500 PSI MIN.
- PROVIDE A MINIMUM 3" CONCRETE COVER OVER ALL EMBEDDED STEEL.
- CONCRETE MUST BE POURED AGAINST UNDISTURBED EARTH SOIL.
- SOIL PASSIVE PRESSURE PER CBC CLASS 5 (100 PCF).

WINLOADS PER ASCE 7-16:

(29.3-1)	F=qs*G*C*Ar	(26.10-1)	qs = 0.00256*Kz*Kd*Ks*Kt*V²
Risk Category:	II		
(26.5)	Wind Speed (V):	150	mph per ATC Council
(Table 26.6-1)	Directional Fac. (Kd):	0.85	(Table 26.6-1)
(26.7)	Exposure Category:	C	
(26.8.2)	Topo Fac. (Kt):	1	(unless unusual terrain)
(26.9)	Ground Elev. Fac. (Ks):	1	(for all elevation)
(26.11)	Gust Effect Fac (G):	0.85	
	z (height of affected area)	0.42	ft
	h (height)	10.25	ft
	B (width of affected area)	5.5	ft
	s/h=	0.04	
	B/s=	13.10	
Force Coefficient (C):	1.9		
Velocity pressure exposure coefficient (Kz):			(Table 29.3-1)
for s/h=1, add 10%			ASCE fig. 29.4-1 therefore: 1.0

Structure Component	Height at section c-g, ft	Kg factor	qs psf	qs*G*Cr ft²	Ar ft²	Shear lb	Wind Moment lb-ft		
1	0.1	0.85	41.62	67.21	0.3	20	2		
2	5.33	0.85	41.62	67.21	3.42	230	1225		
3	10.29	0.85	41.62	67.21	3	202	2075		
4	10.29	0.85	41.62	67.21	2.3	155	1591		
Forces at finish grade							9	606	4893

STEEL REC. 4x4 HSS DESIGN:

Fy:	46 ksi	Area of Sign:	9 ft²	Mu:	4.9 k-ft
E:	29000 ksi	Wind Load:	67.21 psf	Vu:	0.6 kips

Square Member Design:

Size H (in):	4	h/rt:	14.2
Size B (in):	4	b/ft:	14.2
r (in):	1/4	Kt/r:	159.6
Length (ft):	10.25	Fc:	11.23 ksi (E3-4)
K:	2	Max Kt/r:	159.6
Ag (in²):	3.50	4.71sqrt(E/Fy):	118.3
r (in):	1.54	Use:	Eq. 2 Governs
Z (in³):	4.96	Fcr:	Eq. 1 8.28 (E3-2)
S (in²):	4.16	Use:	Eq. 2 9.85 (E3-3)
I (in⁴):	8.32	Flange: b/ft:	14.2 < 1.12V(E/Fy)(k/r) 28 True, Section is Compact
wt (lb):	131	b/ft:	14.2 < 1.40V(E/Fy)(k/r) 35 False, Try other
be:	3.96	Web: h/ft:	14.2 < 2.42V(E/Fy)(k/r) 61 True, Section is Compact
Se:	4.35	h/ft:	14.2 < 5.70V(E/Fy)(k/r) 143 False, Try other

Flexural Buckling: Pn=FcrAg Mu=4.90  
 Yield Moment: Mn=MpFyS Mu=14.35  
 Plastic Moment: Compact Shapes Mn=MpFyZ Mu=17.10  
 Z req: 1.42 in³ Choose Size (Z): 4.96 in³ OKAY 0.29

UNDEBT BURIAL FOOTINGS:

Mu:	4.89 k-ft	(0.6Mu):	2.94 k-ft	w:	1.3	IBC 1805.3.2
Vu:	0.61 kips	(0.6Vu):	0.36 kips			
P:	0.47 kips	S1:	Sxd/3	400.50	psf	IBC 1806.1
Base:	2 ft dia.			1068.00		IBC 1806.3.4
Depth:	4.50 ft deep	A:	2.34*P/(S1xb)	1.38	ft	IBC 1807.3.2.1
h:	8.07 ft					
S:	267 psf/ft	d:	0.5A(1+sqrt(1+4.36hA))	4.24	ft	

BASE PLATE DESIGN:

Mu=	4.89 k-ft	Size:	t:	0.75 in	Nominal Yield Moment	Mnp=Fy*Z:	20.25 k-in
Vu=	0.61 kip	S:	8 in		Phi:	0.9	
Tgrp:	7.34 kip	Arm:	2 in		PhiMnp:	18.23 k-in	
Tb=	7.34 kip/bolt	b eff:	4 in		Demand/Capacity:	0.81 OKAY	
Mu PL=	14.7 k-in	nt:	1 bolts				
S (in²)=	0.375	Steel A36	Ftuw:	36 ksi	Nominal Yield Moment	Mnp=Fy*Z:	20.25 k-in
Z (in³)=	0.563	Ftyw:	36 ksi		Phi:	0.9	
		Fcyw:	36 ksi		PhiMnp:	18.23 k-in	
		Kt:	1		Demand/Capacity:	0.81 OKAY	

REGISTERED PROFESSIONAL ENGINEER  
 YOSIMAR RAMOS  
 No. 89832  
 Exp. 6/30/23  
 CIVIL  
 STATE OF CALIFORNIA

*Yosimar Ramos*  
 YOSIMAR RAMOS  
 R.C.E. 89832  
 LIC. EXP 06/30/23

PREPARED BY:

YR ENGINEERING LP  
 424 E. MAITLAND ST. STE. A  
 ONTARIO, CA 91761  
 PHONE: (626) 374-5881  
 EMAIL: YRAMOS@YRENGINEERING.COM

STARBUCKS DRIVE THRU SIGNAGE  
 CLEARANCE BAR DETAILS  
 VARIOUS LOCATIONS, CALIFORNIA

PREPARED FOR: SIGN INDUSTRIES, INC.

CHECKED BY: YR      JOB NO: 2131-01      SHEET: 1 OF 1

DISREGARD PRINTS BEARING EARLIER REVISION DATES → 10-11-21      03-23-22



PRE-MENU SIGN

**FRONT ELEVATION**

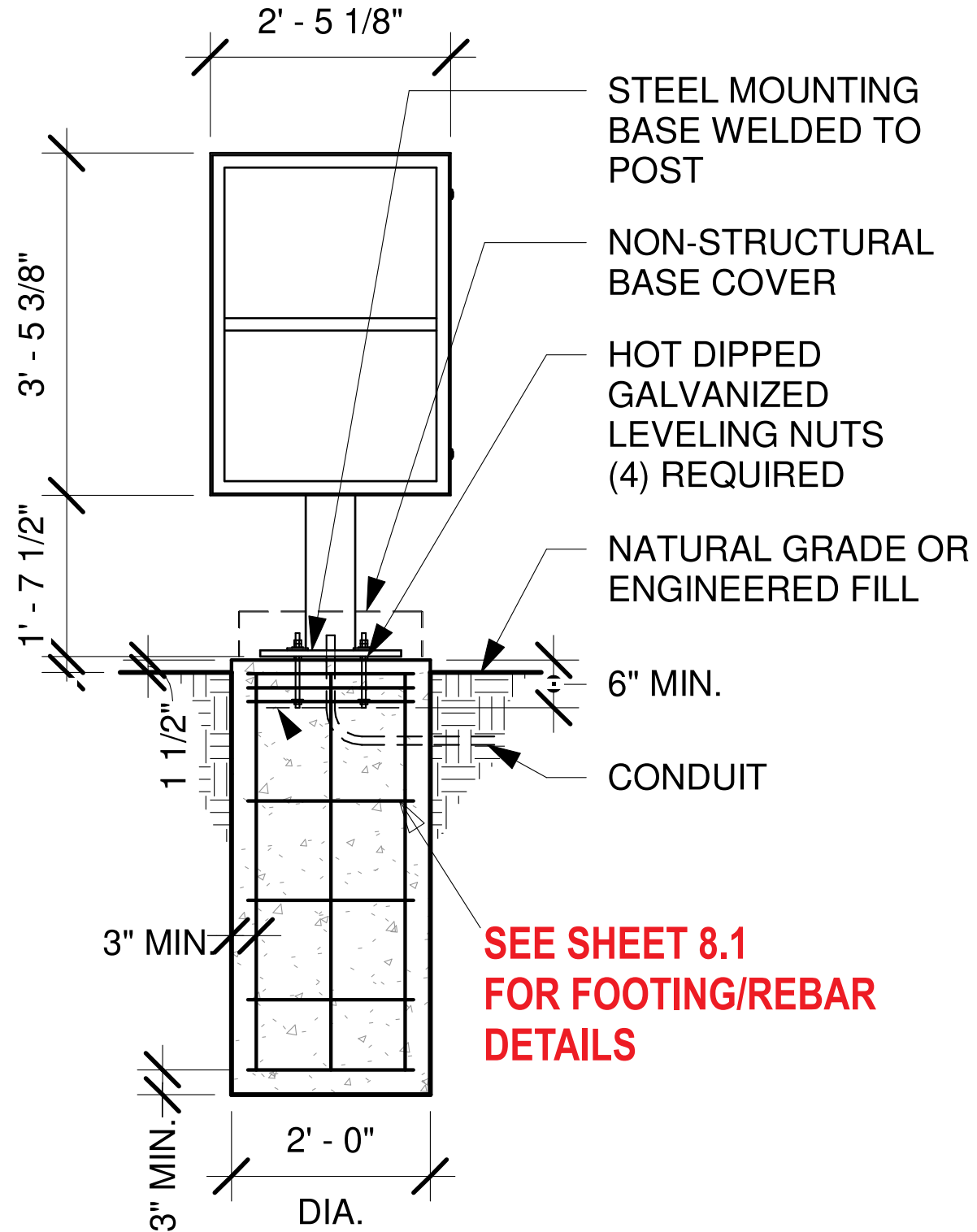

**SIDE ELEVATION**

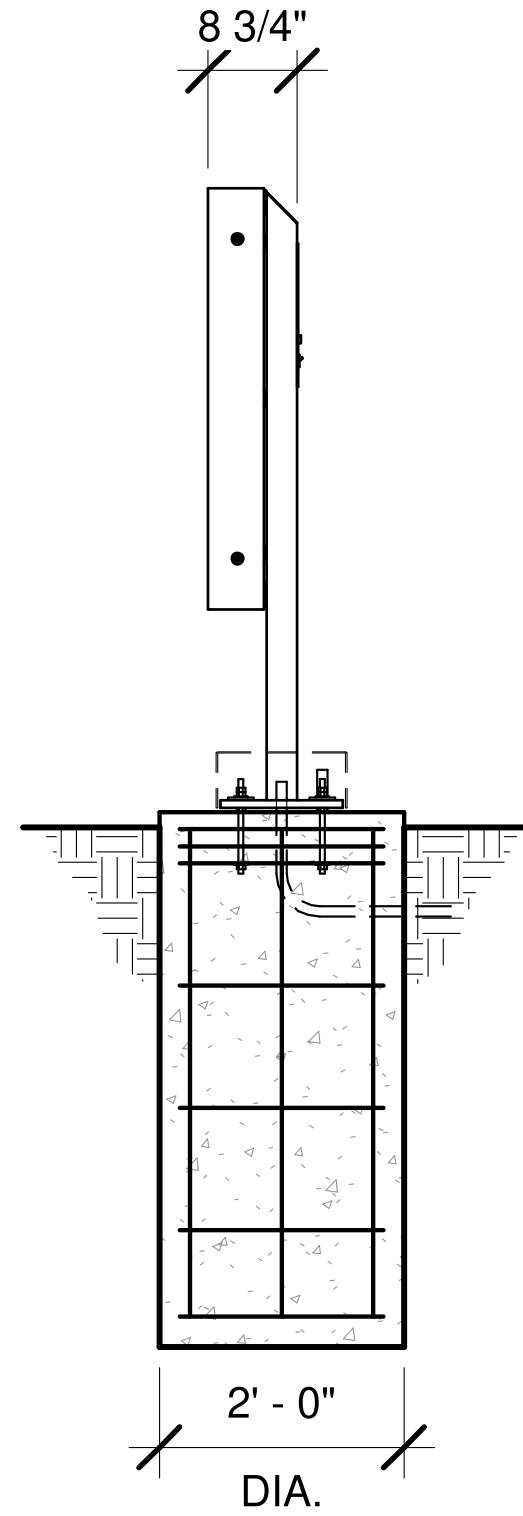

STEEL MOUNTING  
BASE WELDED TO  
POST

NON-STRUCTURAL  
BASE COVER

HOT DIPPED  
GALVANIZED  
LEVELING NUTS  
(4) REQUIRED

NATURAL GRADE OR  
ENGINEERED FILL

6" MIN.

CONDUIT

**SEE SHEET 8.1  
FOR FOOTING/REBAR  
DETAILS**

Project:



Location:

Client Approval:

Date of Approval:

Sales Rep:

Paul L.

Date:

Drawn by:

L.S.

1		
2		
3		
4		
5		
6		

Electrical Requirement:

120 Volts

277 Volts



2101 Carrillo Privado, Ontario, CA 91761  
(909) 930-0303 Fax: (909) 930-0308  
E-mail: design@signindustries.tv  
Web: www.signindustries.tv

All ideas, plans or arrangements indicated on this drawing are copyrighted and owned by Sign Industries Incorporated and shall not be reproduced, used by or disclosed to any persons, firm or corporation for any purpose whatsoever without written permission of Sign Industries Incorporated.





1		
2		
3		
4		
5		
6		

Electrical Requirement:

120 Volts  277 Volts



2101 Carrillo Privado, Ontario, CA 91761  
 (909) 930-0303 Fax: (909) 930-0308  
 E-mail: design@signindustries.tv  
 Web: www.signindustries.tv

All ideas, plans or arrangements indicated on this drawing are copyrighted and owned by Sign Industries Incorporated and shall not be reproduced, used by or disclosed to any persons, firm or corporation for any purpose whatsoever without written permission of Sign Industries Incorporated.

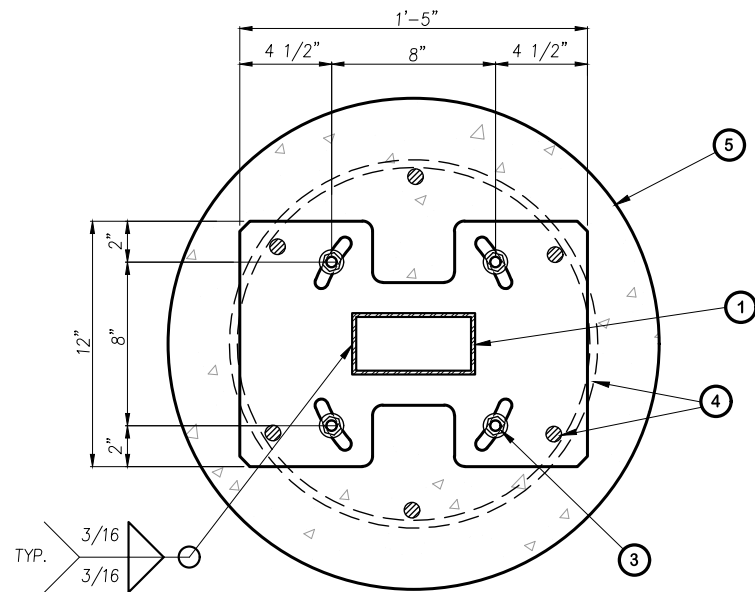
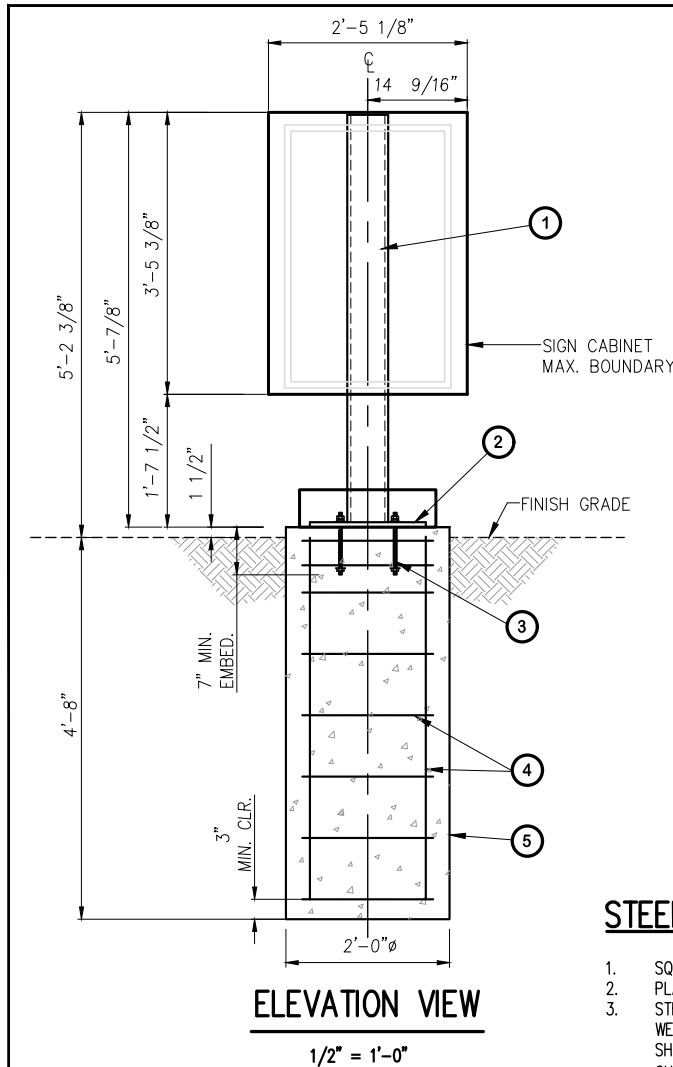

**STEEL:**

1. SQ/RECT. HSS: ASTM A500, GR. B Fy=46 KSI
2. PLATE STEEL: ASTM A36 Fy=36 KSI
3. STRUCTURAL STEEL MEMBERS SHALL BE SHEARED, FORMED, PUNCHED, WELDED, AND PAINTED BY THE MANUFACTURER. ALL SHOP CONNECTIONS SHALL BE WELDED IN CONFORMANCE WITH STANDARDS BASED UPON THE CURRENT EDITION OF ANSI/AWS D1.1. WELDERS AND WELDING OPERATORS SHALL BE QUALIFIED AS PROVIDED IN THE CODE.

**CONCRETE:**

1. DESIGN AND CONSTRUCTION IN COMPLIANCE TO ACI 318-14.
2. STEEL REINFORCEMENT IN CONCRETE ASTM A615 GRADE 60.
3. COMPRESSIVE STRENGTH AT 28 DAYS: f'c=2500 PSI MIN.
4. PROVIDE A MINIMUM 3" CONCRETE COVER OVER ALL EMBEDDED STEEL.
5. CONCRETE MUST BE POURED AGAINST UNDISTURBED EARTH SOIL.
6. SOIL PASSIVE PRESSURE PER CBC CLASS 5 (100 PCF).

**GENERAL NOTES:**

1. ALL WORK SHALL BE IN ACCORDANCE WITH THE LATEST EDITIONS OF THE STANDARD SPECIFICATIONS FOR PUBLIC WORKS CONSTRUCTION, THE 2019 CALIFORNIA BUILDING CODE (CBC), AND 2018 INTERNATIONAL BUILDING CODE (IBC).
2. ANY CONFLICTS BETWEEN THESE DRAWINGS, STANDARDS NOTED HEREIN, PROJECT REQUIREMENTS, AND/OR OTHER REFERENCE DOCUMENTS SHALL BE BROUGHT TO THE ATTENTION OF THE CIVIL ENGINEER, WHERE CONFLICTS OCCUR, THE MOST STRINGENT REQUIREMENTS SHALL BE FOLLOWED.
3. PROVIDE ISOLATION OF DISSIMILAR MATERIALS

**DESIGN CRITERIA:**

1. STRUCTURE IS DESIGNED IN ACCORDANCE WITH ASCE 7-16  
 BASIC WIND SPEED: 150 MPH  
 RISK CATEGORY: II  
 EXPOSURE CATEGORY: C  
 SITE CLASS: D  
 OCCUPANCY CATEGORY: II  
 SEISMIC DESIGN CATEGORY: D  
 IMPORTANCE FACTOR: 1.0  
 RESPONSE MODIFICATION FACTOR: Rp=3.0  
 AMPLIFICATION FACTOR: Ap=2.5

REGISTERED PROFESSIONAL ENGINEER  
 YOSIMAR RAMOS  
 No. 89832  
 Exp. 6/30/23  
 CIVIL  
 STATE OF CALIFORNIA

*Yosimar Ramos*  
 YOSIMAR RAMOS  
 R.C.E. 89832  
 LIC. EXP 06/30/23

PREPARED BY:

**YR**  
 ENGINEERING LP

YR ENGINEERING LP  
 424 E. MAITLAND ST. STE. A  
 ONTARIO, CA 91761  
 PHONE: (626) 374-5881  
 EMAIL: YRAMOS@YRENGINEERING.COM

WINLOADS PER ASCE 7-16:

(29.3-1)	F <sub>w</sub> =q <sub>w</sub> *G*C*A <sub>w</sub>	(26.10-1)	q <sub>w</sub> = 0.00256*K <sub>z</sub> *K <sub>e</sub> *K <sub>d</sub> *K <sub>f</sub> *V <sup>2</sup>
	Risk Category: II		
(26.5)	Wind Speed (V):	150	mph per ATC Council
(Table 26.6-1)	Directional Fac. (K <sub>d</sub> ):	0.85	(Table 26.6-1)
(26.7)	Exposure Category:	C	
(26.8.2)	Topo Fac. (K <sub>e</sub> ):	1	(unless unusual terrain)
(26.9)	Ground Elev. Fac. (K <sub>g</sub> ):	1	(for all elevation)
(26.11)	Gust Effect Fac. (G):	0.85	
	s (height of affected area)	3.45	ft
	h (height)	5.2	ft
	B (width of affected area)	2.43	ft
	s/h=	0.66	
	B/s=	0.70	
	Force Coefficient (C <sub>f</sub> ):	1.692	(Table 29.3-1)
	Velocity pressure exposure coefficient (K <sub>e</sub> ):		(Table 29.3-1)
	for s/h>1, add 10%	ASCE fig. 29.4-1 therefore:	1.0

Structure Component	Height at section c.g. ft	(Table 26.10-1) K <sub>e</sub> factor	q <sub>w</sub> psf	q <sub>w</sub> *G*C <sub>f</sub> psf	A <sub>w</sub> ft <sup>2</sup>	Shear lb	Wind Moment lb-ft		
1	0.25	0.85	41.62	59.87	2	120	30		
2	1.04	0.85	41.62	59.87	2	120	125		
3	3.47	0.85	41.62	59.87	8.37	501	1739		
Forces at finish grade							12	741	1893

DIRECT BURIAL FOOTING:

M <sub>u</sub> :	1.89	k-ft	(0.6Mu):	1.14	k-ft	w:	1.3	IBC 1805.3.2
V <sub>u</sub> :	0.74	kips	(0.8Vu):	0.64	kips			
P:	0.58	kips	S1:	Sx2/3		328.63	psf	IBC 1806.1
Base:	2	ft dia.	A:	2.34**/S1x3		2.07	ft	IBC 1807.3.1
Depth:	3.67	ft deep						
h:	2.56	ft						
S:	267	psf/ft	d:	0.5A(1+(1+(4.36h/A)))		3.65	ft	

STEEL COLUMN DESIGN:

F <sub>yc</sub> :	46	ksi	Area of Sign:	12	ft <sup>2</sup>	M <sub>u</sub> :	1.89	k-ft
E:	29000	ksi	Wind Load:	59.87	psf	V <sub>u</sub> :	0.74	kips

Square Member Design

Size H (in):	3	h/t=	14.2				
Size B (in):	6	b/t=	31.4				
t (in):	3/16	K <sub>u</sub> /r=	100.7				
Length (ft):	5.23	F <sub>e</sub> =	28.23 ksi (E3-4)				
K <sub>1</sub> :	2	Max K <sub>u</sub> /r=	100.7				
A <sub>g</sub> (in <sup>2</sup> ):	3.02	4.71sqrt(E/F <sub>y</sub> )=	118.3				
r (in):	1.25	Use:	Eq. 1	Governs			
Z (in <sup>3</sup> ):	3.57	F <sub>cr</sub> =	Eq. 1	23.25	(E3-2)		
S (in <sup>3</sup> ):	3.15		Eq. 2	24.75	(E3-3)		
I (in <sup>4</sup> ):	4.72	Flange: b/t=	31.4	< 1.12V(E/F <sub>y</sub> )(k <sub>p</sub> )=	28	False, Try Other	
wt (lb):	58	b/t=	31.4	< 1.40V(E/F <sub>y</sub> )(k <sub>p</sub> )=	35	True, Section is Non Compact	
h <sub>e</sub> :	2.97	Web: h/t=	14.2	< 2.42V(E/F <sub>y</sub> )(k <sub>p</sub> )=	61	True, Section is Compact	
S <sub>e</sub> :	3.30	h/t=	14.2	< 5.70V(E/F <sub>y</sub> )(k <sub>p</sub> )=	143	False, Try other	

Flexural Buckling: P<sub>n</sub>=F<sub>cr</sub>A<sub>g</sub> φ<sub>p</sub>=0.90 φ<sub>p</sub>C<sub>m</sub>= 0.315 kips (E3-2)

Yield Moment: M<sub>n</sub>=F<sub>y</sub>Z φ<sub>y</sub>= 10.39 k-ft

Plastic Moment: Compact Shapes M<sub>n</sub>=M<sub>p</sub>=F<sub>y</sub>Z φ<sub>m</sub>= 12.31 k-ft (E3-1)

Local Buckling: Non Compact Shapes Flange M<sub>n</sub>=M<sub>p</sub>-(M<sub>p</sub>-F<sub>y</sub>S)(3.57b/t V(F<sub>y</sub>/E)-4.0) φ<sub>m</sub>= 11.64 k-ft (E3-2)

Local Buckling: Non Compact Shapes Web M<sub>n</sub>=M<sub>p</sub>-(M<sub>p</sub>-F<sub>y</sub>S)(0.305h/t V(F<sub>y</sub>/E)-0.738) φ<sub>m</sub>= 13.13 k-ft (E3-2)

Z<sub>req</sub>: 0.55 in<sup>3</sup> Choose Size (Z): 3.57 in<sup>3</sup> OKAY φ<sub>t</sub>= 0.15

BASE PLATE DESIGN:

Base Plate Check:

M <sub>u</sub> :	1.89	k-ft	Size:	t:	0.75	in	Nominal Yield Moment	M <sub>np</sub> =F <sub>y</sub> Z:	10.13	k-in
V <sub>u</sub> :	0.74	kips	S:	8	in	φ <sub>b</sub> :	0.9			
T <sub>grp</sub> :	2.84	kip	Arm:	2.5	in	φ <sub>b</sub> M <sub>np</sub> :	9.11	k-in		
T <sub>b</sub> :	1.42	kip/bolt	b <sub>eff</sub> :	2	in	Demand/Capacity:	0.39	OKAY		
M <sub>u</sub> PL:	3.5	k-in	bolts:	2	bolts					

Material Steel A36

F <sub>u</sub> w:	36	ksi	Nominal Yield Moment	M <sub>np</sub> =F <sub>y</sub> Z:	10.13	k-in
F <sub>y</sub> w:	36	ksi	φ <sub>b</sub> :	0.9		
F <sub>cyw</sub> :	36	ksi	φ <sub>b</sub> M <sub>np</sub> :	9.11	k-in	
K <sub>t</sub> :	1		Demand/Capacity:	0.39	OKAY	

STARBUCKS DRIVE THRU SIGNAGE  
 PRE-MENU BOARD  
 VARIOUS LOCATIONS, CALIFORNIA

PREPARED FOR: SIGN INDUSTRIES, INC.

CHECKED BY:	YR	JOB NO:	2131-00	SHEET:	1 OF 1
DISREGARD PRINTS BEARING EARLIER REVISION DATES			10-12-21		

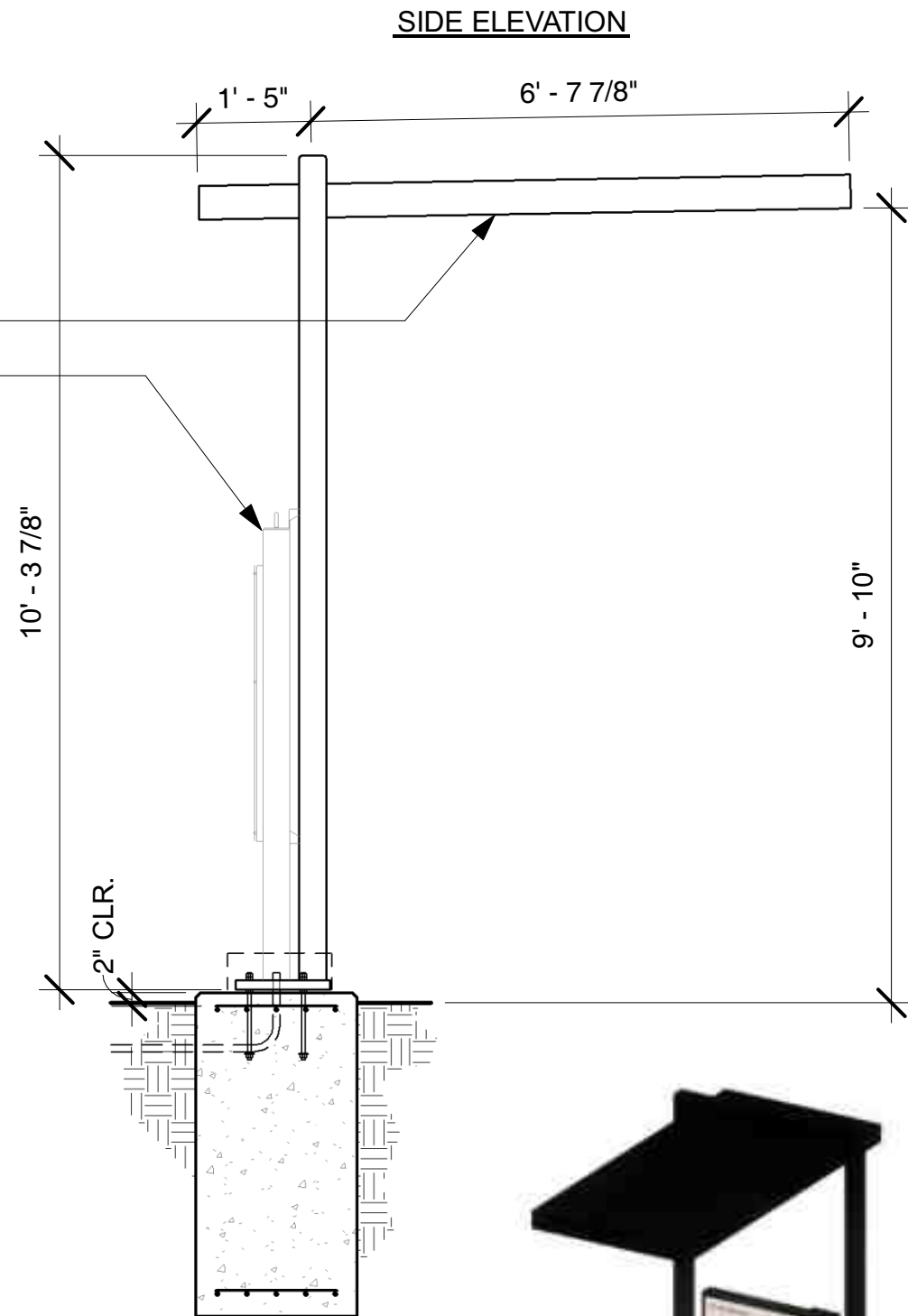
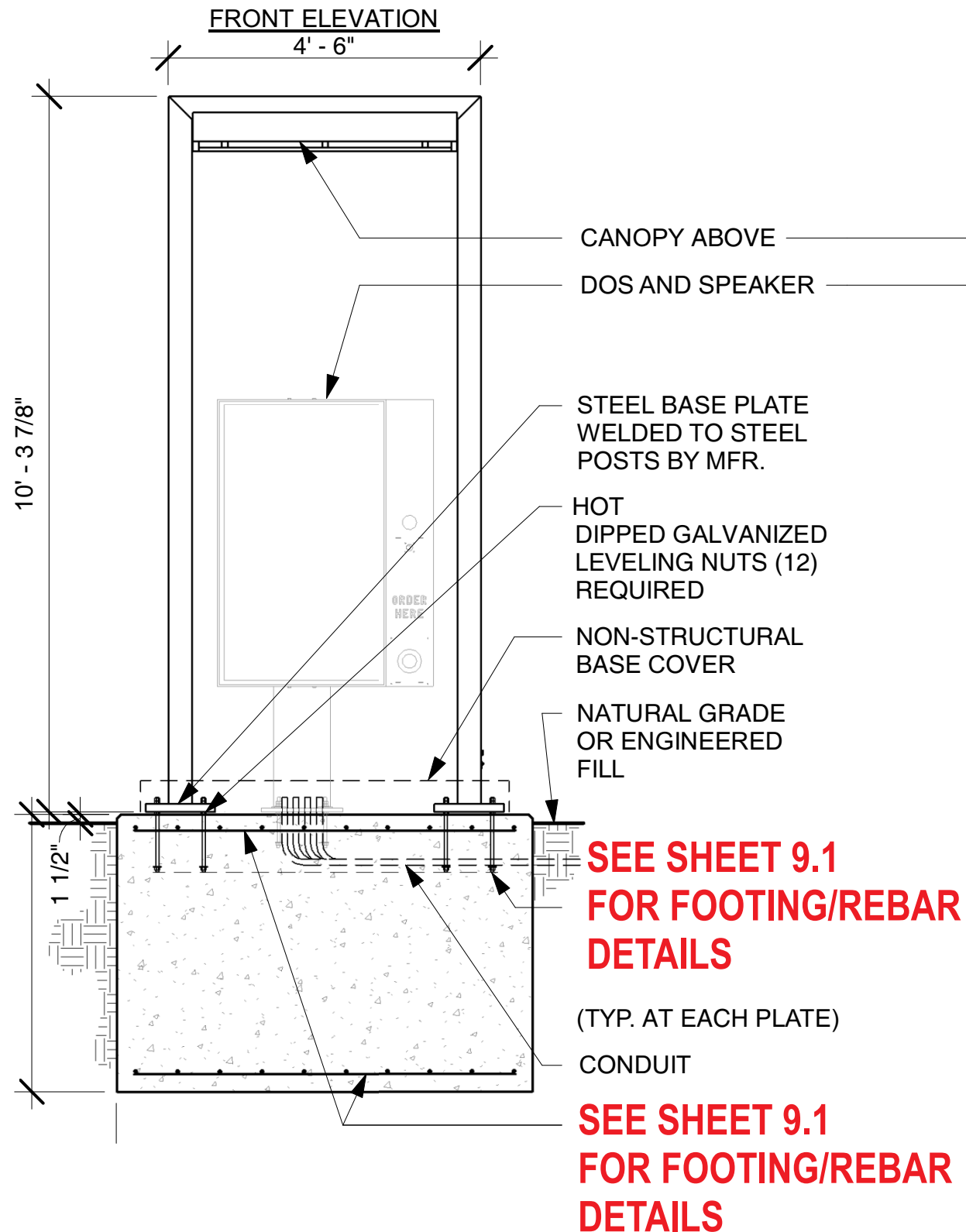

CANOPY WITH DOS

Project:



Location:

Client Approval:

Date of Approval:

Sales Rep:

Paul L.

Date:

Drawn by:

L.S.

1		
2		
3		
4		
5		
6		

Electrical Requirement:

120 Volts

277 Volts



2101 Carrillo Privado, Ontario, CA 91761  
 (909) 930-0303 Fax: (909) 930-0308  
 E-mail: design@signindustries.tv  
 Web: www.signindustries.tv

All ideas, plans or arrangements indicated on this drawing are copyrighted and owned by Sign Industries Incorporated and shall not be reproduced, used by or disclosed to any persons, firm or corporation for any purpose whatsoever without written permission of Sign Industries Incorporated.

Drawing No

22-256



Page: 9.0



1		
2		
3		
4		
5		
6		

Electrical Requirement:

120 Volts  277 Volts



2101 Carrillo Privado, Ontario, CA 91761  
 (909) 930-0303 Fax: (909) 930-0308  
 E-mail: design@signindustries.tv  
 Web: www.signindustries.tv

All ideas, plans or arrangements indicated on this drawing are copyrighted and owned by Sign Industries Incorporated and shall not be reproduced, used by or disclosed to any persons, firm or corporation for any purpose whatsoever without written permission of Sign Industries Incorporated.

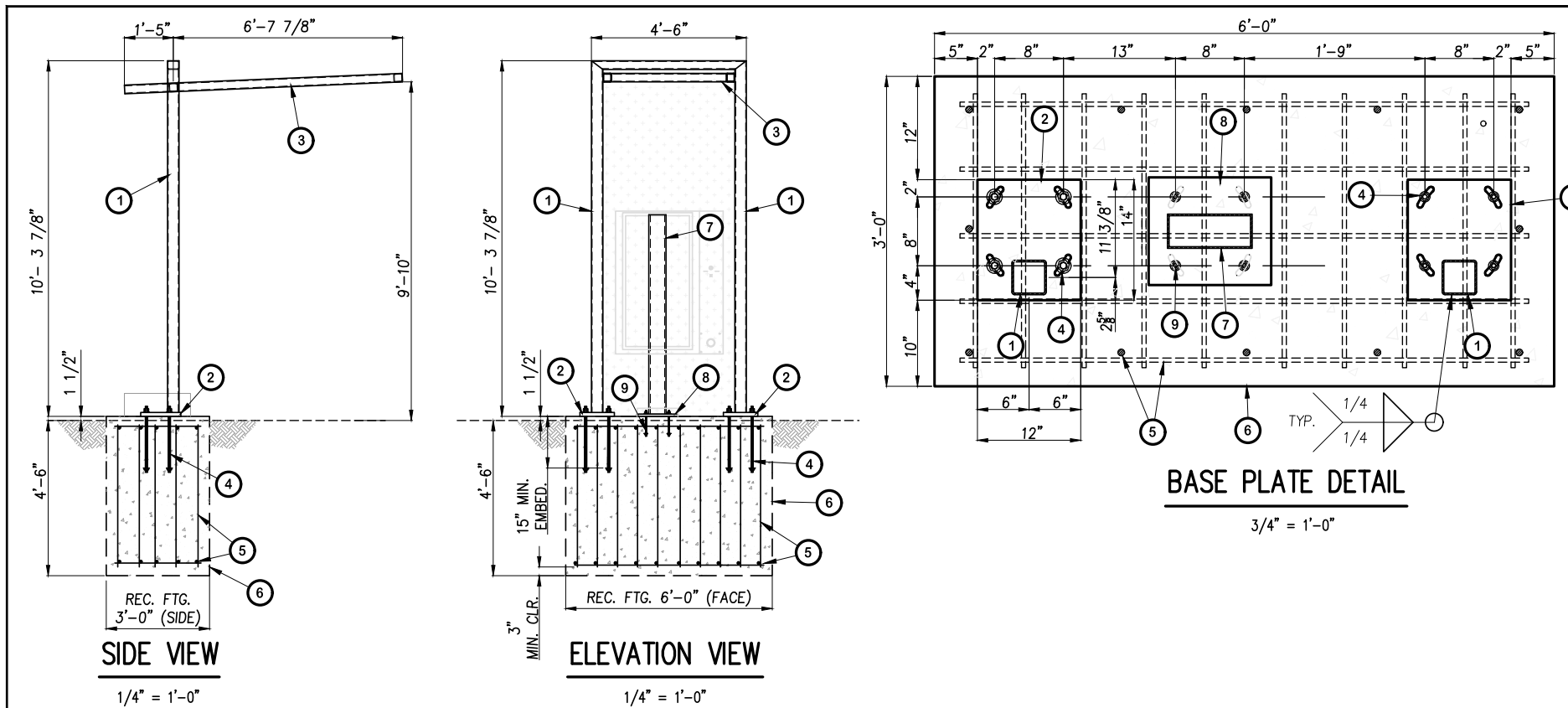

WINLOADS PER ASCE 7-16:

Directional Procedure (29.3-1)	$F=q_s \cdot G \cdot C_e \cdot A_s$	(26.10-1)	$q_s = 0.00256 \cdot K_z \cdot K_{zt} \cdot K_d \cdot K_e \cdot V^2$
Risk Category:	II		mph per ATC Council
Wind Speed (V):	150		
Directional Fac. ( $K_d$ ):	0.85	(Table 26.6-1)	
Exposure Category:	C	(Table 26.7)	
Topo Fac. ( $K_e$ ):	1	(unless unusual terrain)	
Ground Elev. Fac. ( $K_g$ ):	1	(for all elevation)	
Gust Effect Fac. (G):	0.85		
s (height of affected area)	10.33	ft	
h (height)	10.33	ft	
B (width of affected area)	4.5	ft	
	s/h=	1.00	
	B/s=	0.44	
Force Coefficient ( $C_f$ ):	1.65		
Velocity pressure exposure coefficient ( $K_z$ ):		(Table 29.3-1)	
for s/h=1, add 10%		ASCE fig. 29.4-1 therefore:	1.1

(Table 26.10-1)	$q_s$	$q_s \cdot G \cdot C_e$
$K_z$ factor	psf	psf
0.85	41.62	58.37

DIRECT BURIAL FOOTING:

$M_u$ :	12.06	k-ft	(0.6 $M_u$ ):	7.24	k-ft	w:	1.3	IBC 1605.3.2
$V_u$ :	2.16	kips	(0.6 $V_u$ ):	1.30	kips			
P	1.69	kips	S1:	Ssd/3		362.67	psf	IBC 1806.1
Base:	6.71	ft dia.				12	ft or	1068
Depth:	4.08	ft deep	A:	2.34*P/(S1xb)		1.62	ft	IBC 1807.3.2.1
h	5.57	ft						
S	100	psf/ft	d:	0.5Av(1+(4.36hA))		4.05	ft	
S'	266.667	psf/ft						IBC Table 1806.2

BASE PLATE DESIGN:

$M_u$ =	6.00	k-ft	Size:	t:	1.375	in	Nominal Yield Moment	$M_{np}=F_y \cdot Z:$	68.06	k-in
	72.00	k-in	S:	8	in		$\phi_b$ :	0.9		
$V_u$ =	1.40	kip	Arm:	8	in		$\phi_b M_{np}$ :	61.26	k-in	
			b eff:	4	in		Demand/Capacity:	0.59	OKAY	
Tgrp:	9.00	kip	n:	2	bolts					
Tb=	4.50	kip/bolt	Steel A36			Nominal Yield Moment	$M_{np}=F_y \cdot Z:$	68.06	k-in	
$M_u$ PL=	36.0	k-in	F <sub>tw</sub> :	36	ksi	$\phi_b$ :	0.9			
			F <sub>tw</sub> :	36	ksi	$\phi_b M_{np}$ :	61.26	k-in		
S (in <sup>3</sup> )=	1.260		F <sub>cyw</sub> :	36	ksi	Demand/Capacity:	0.59	OKAY		
Z (in <sup>3</sup> )=	1.891		Kt:	1						

- 1 (2) 4"x4"x1/4" SQ. HSS FRAME PER ELEVATION AND BASE PLATE DETAIL HEREON.
- 2 (2) 1 3/8" THK. STEEL BASE PLATE (12"x14") PER BASE PLATE DETAIL HEREON.
- 3 3"x3"x1/4" SQ. HSS FRAME PER ELEVATION HEREON.
- 4 TOTAL (8) 3/4" THREADED HOT DIPPED GALVANIZED ANCHOR RODS (ASTM F1554 GRADE 55) WITH GALVANIZED HARDWARE PER ELEVATION AND BASE PLATE DETAILS HEREON.
- 5 HORIZ: (5) #5 LONG LENGTH AND (10) #5 SHORT LENGTH AT TOP AND BOTTOM EACH WAY  
VERT: (12) #5 BAR SPACES EVENLY AROUND PERIMETER CLEARANCE 3" MIN. TO EDGE OF CONC.
- 6 CONCRETE FOOTING PER PLAN AND SPECIFICATIONS HEREON.
- 7 9.873"x3.93"x3/16" SQ. HSS POST
- 8 5/8" THK. STEEL BASE PLATE (12.5"x14.25") PER BASE PLATE DETAIL.
- 9 (4) 1/2" THREADED HOT DIPPED GALVANIZED ANCHOR RODS (ASTM F1554 GRADE 55) WITH GALVANIZED HARDWARE PER ELEVATION AND BASE PLATE DETAIL.

GENERAL NOTES:

1. ALL WORK SHALL BE IN ACCORDANCE WITH THE LATEST EDITIONS OF THE STANDARD SPECIFICATIONS FOR PUBLIC WORKS CONSTRUCTION, THE 2019 CALIFORNIA BUILDING CODE (CBC), AND 2018 INTERNATIONAL BUILDING CODE (IBC).
2. ANY CONFLICTS BETWEEN THESE DRAWINGS, STANDARDS NOTED HEREIN, PROJECT REQUIREMENTS, AND/OR OTHER REFERENCE DOCUMENTS SHALL BE BROUGHT TO THE ATTENTION OF THE CIVIL ENGINEER, WHERE CONFLICTS OCCUR, THE MOST STRINGENT REQUIREMENTS SHALL BE FOLLOWED.
3. PROVIDE ISOLATION OF DISSIMILAR MATERIALS

STEEL:

1. SQ/RECT. HSS: ASTM A500, GR. B F<sub>y</sub>=46 KSI
2. PLATE STEEL: ASTM A36 F<sub>y</sub>=36 KSI
3. STRUCTURAL STEEL MEMBERS SHALL BE SHEARED, FORMED, PUNCHED, WELDED, AND PAINTED BY THE MANUFACTURER. ALL SHOP CONNECTIONS SHALL BE WELDED IN CONFORMANCE WITH STANDARDS BASED UPON THE CURRENT EDITION OF ANSI/AWS D1.1. WELDERS AND WELDING OPERATORS SHALL BE QUALIFIED AS PROVIDED IN THE CODE.

DESIGN CRITERIA:

1. STRUCTURE IS DESIGNED IN ACCORDANCE WITH ASCE 7-16  
 BASIC WIND SPEED: 150 MPH  
 RISK CATEGORY: II  
 EXPOSURE CATEGORY: C  
 SITE CLASS: D  
 OCCUPANCY CATEGORY: II  
 SEISMIC DESIGN CATEGORY: D  
 IMPORTANCE FACTOR: 1.0  
 RESPONSE MODIFICATION FACTOR: R<sub>p</sub>=3.0  
 AMPLIFICATION FACTOR: A<sub>p</sub>=2.5

CONCRETE:

1. DESIGN AND CONSTRUCTION IN COMPLIANCE TO ACI 318-14.
2. STEEL REINFORCEMENT IN CONCRETE ASTM A615 GRADE 60.
3. COMPRESSIVE STRENGTH AT 28 DAYS: f'<sub>c</sub>=2500 PSI MIN.
4. PROVIDE A MINIMUM 3" CONCRETE COVER OVER ALL EMBEDDED STEEL.
5. CONCRETE MUST BE POURED AGAINST UNDISTURBED EARTH SOIL.
6. SOIL PASSIVE PRESSURE PER CBC CLASS 5 (100 PCF).

PREPARED BY:

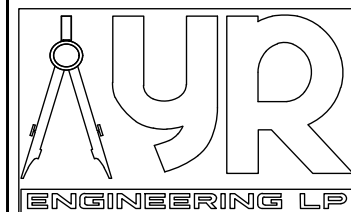

YR ENGINEERING LP  
 424 E. MAITLAND ST. STE. A  
 ONTARIO, CA 91761  
 PHONE: (626) 374-5881  
 EMAIL: YRAMOS@YRENGINEERING.COM

STARBUCKS DRIVE THRU SIGNAGE  
 DIGITAL ORDER SCREEN CANOPY  
 VARIOUS LOCATIONS, CALIFORNIA

PREPARED FOR: SIGN INDUSTRIES, INC.

CHECKED BY: YR	JOB NO: 2131-00	SHEET: 1 OF 1
DISREGARD PRINTS BEARING EARLIER REVISION DATES	10-13-21	12-27-21



*Yosimar Ramos*  
 YOSIMAR RAMOS  
 R.C.E. 89832  
 LIC. EXP 06/30/23



5-PANEL MENU SIGN

**FRONT ELEVATION**

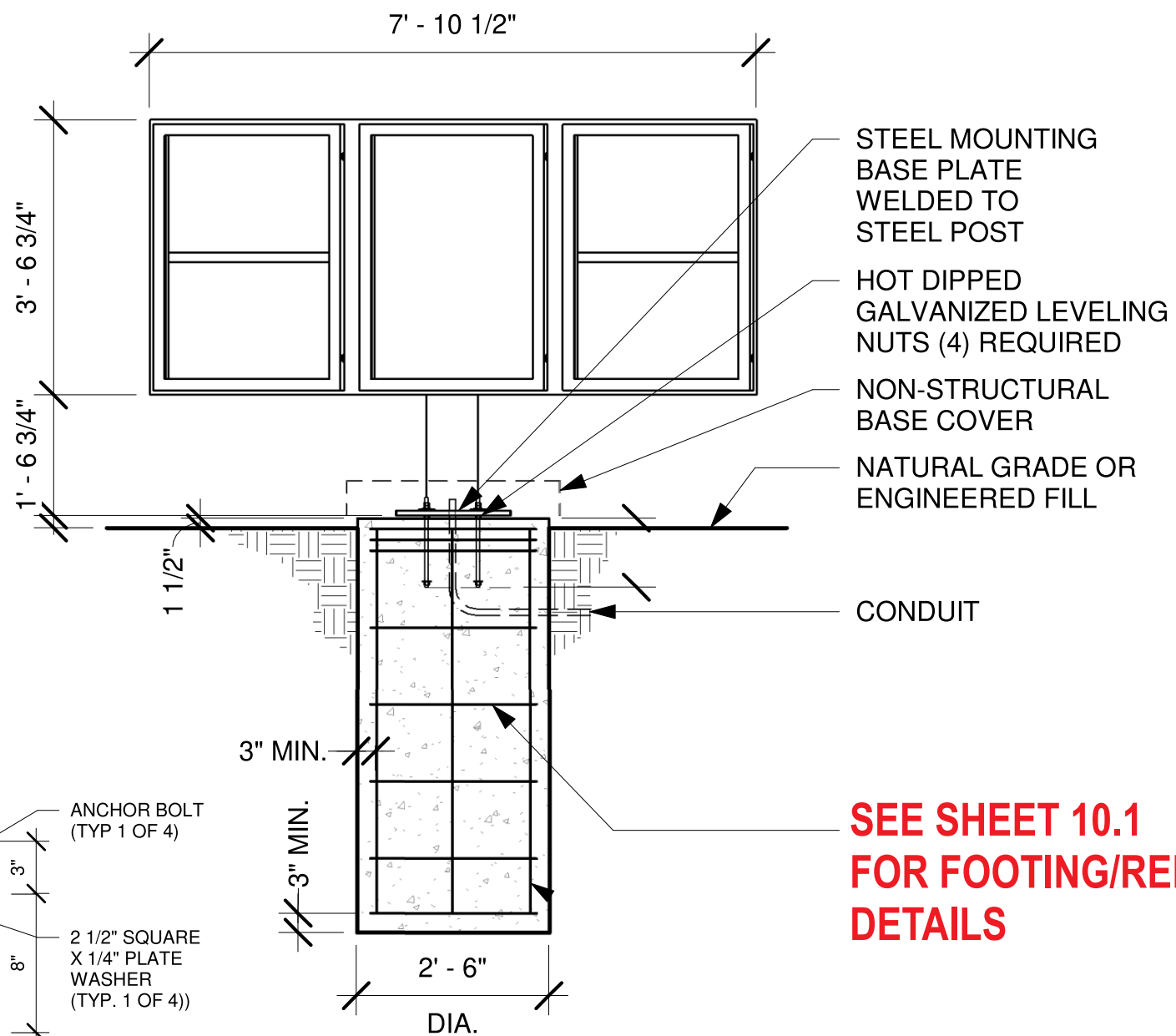

**SIDE ELEVATION**

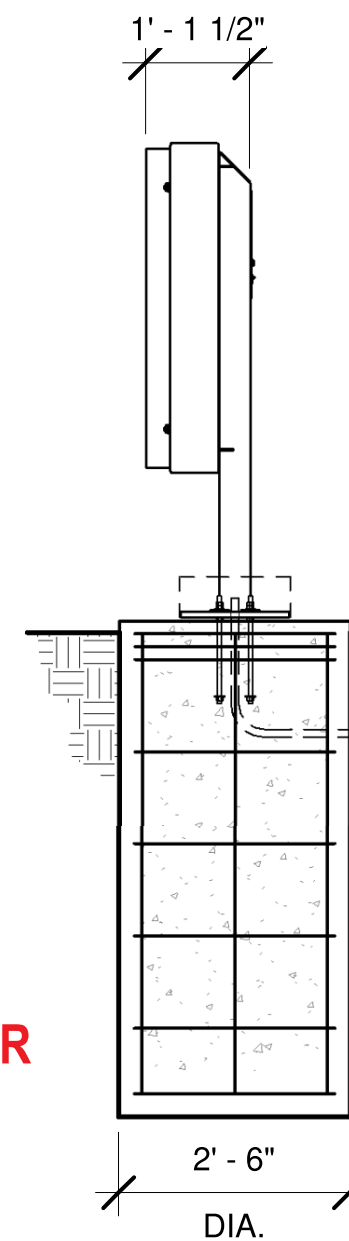

**SEE SHEET 10.1 FOR FOOTING/REBAR DETAILS**

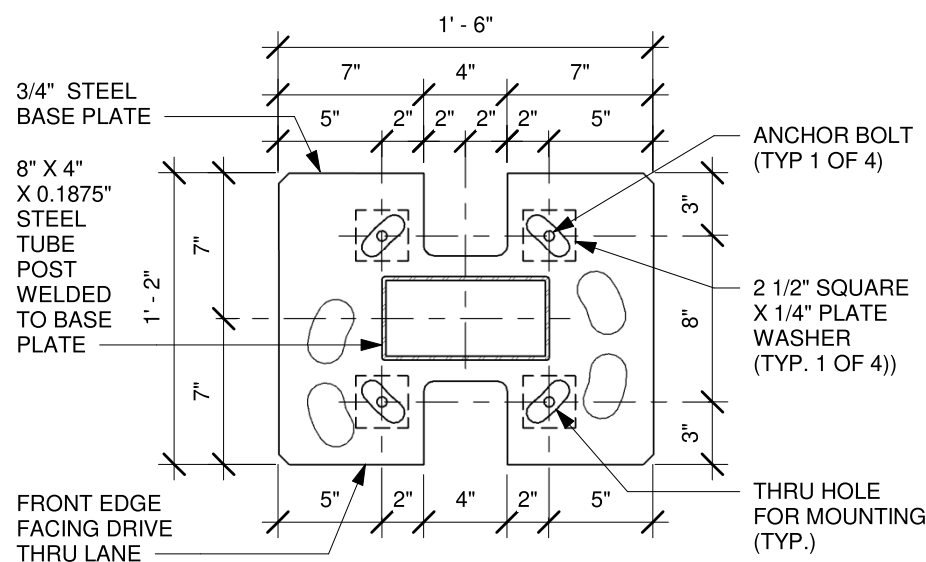

**2 BASE PLATE**

Scale: 1 1/2" = 1'-0"

**1 DRIVE THRU 5-PANEL MENU SIGN ~ Qty (1)**  
INSTALLATION ONLY

Scale: 1" = 3/4"

Sq. Ft.  
**36**

Project:



Location:

Client Approval:

Date of Approval:

Sales Rep:

Paul L.

Date:

Drawn by:

L.S.

1		
2		
3		
4		
5		
6		

Electrical Requirement:

120 Volts

277 Volts



2101 Carrillo Privado, Ontario, CA 91761  
(909) 930-0303 Fax: (909) 930-0308  
E-mail: design@signindustries.tv  
Web: www.signindustries.tv

All ideas, plans or arrangements indicated on this drawing are copyrighted and owned by Sign Industries Incorporated and shall not be reproduced, used by or disclosed to any persons, firm or corporation for any purpose whatsoever without written permission of Sign Industries Incorporated.

Drawing No

**22-256**



Page: **10.0**



1		
2		
3		
4		
5		
6		

Electrical Requirement:

120 Volts  277 Volts



2101 Carrillo Privado, Ontario, CA 91761  
 (909) 930-0303 Fax: (909) 930-0308  
 E-mail: design@signindustries.tv  
 Web: www.signindustries.tv

All ideas, plans or arrangements indicated on this drawing are copyrighted and owned by Sign Industries Incorporated and shall not be reproduced, used by or disclosed to any persons, firm or corporation for any purpose whatsoever without written permission of Sign Industries Incorporated.



**ELEVATION VIEW**  
3/8" = 1'-0"

**DIRECT BURIAL FOOTING:**

Mu:	5.68 k-ft	(0.6Mu):	3.41 k-ft	w:	1.3	IBC 1805.3.2
Vu:	1.83 kips	(0.6Vu):	1.10 kips			
P:	1.42 kips	S1:	Sxd/3	445.00 psf		IBC 1806.1
Base	2.5 ft dia.	A:	2.34*P/(S1xb)	1068.00		A1806.3.4
Depth	5.00 ft deep			2.99 ft		IBC 1807.3.2.1
h	3.11 ft	d:	0.5A(1+v)/(1+4.36hA)	5.02 ft		
S	267 psf/ft					IBC Table 1806.2

**WINLOADS PER ASCE 7-16:**

(29.3-1)	F=qr*G*C <sub>r</sub> *A <sub>s</sub>	(26.10-1)	q <sub>r</sub> = 0.00256*K <sub>z</sub> *K <sub>dt</sub> *K <sub>e</sub> *V <sup>2</sup>
	Risk Category:	II	
(26.5)	Wind Speed (V):	150	mph per ATC Council
(Table 26.6-1)	Directional Fac. (K <sub>d</sub> ):	0.85	(Table 26.6-1)
(26.7)	Exposure Category:	C	
(26.8.2)	Topo Fac. (K <sub>e</sub> ):	1	(unless unusual terrain)
(26.9)	Ground Elev. Fac. (K <sub>g</sub> ):	1	(for all elevation)
(26.11)	Gust Effect Fac (G):	0.85	
	s (height of affected area)	3.56	ft
	h (height)	5.25	ft
	B (width of affected area)	7.88	ft
	s/h=	0.68	
	B/s=	2.21	
	Force Coefficient (C <sub>f</sub> ):	1.61	
	Velocity pressure exposure coefficient (K <sub>e</sub> ):		(Table 29.3-1)
	for s/h=1, add 10%	ASCE fig. 29.4-1 therefore:	1.0

**BASE PLATE DETAIL**  
1" = 1'-0"

**DESIGN CRITERIA:**

- STRUCTURE IS DESIGNED IN ACCORDANCE WITH ASCE 7-16  
 BASIC WIND SPEED: 150 MPH  
 RISK CATEGORY: II  
 EXPOSURE CATEGORY: C  
 SITE CLASS: D  
 OCCUPANCY CATEGORY: II  
 SEISMIC DESIGN CATEGORY: D  
 IMPORTANCE FACTOR: 1.0  
 RESPONSE MODIFICATION FACTOR: Rp=3.0  
 AMPLIFICATION FACTOR: Ap=2.5

**STEEL:**

- SQ/RECT. HSS: ASTM A500, GR. B Fy=46 KSI
- PLATE STEEL: ASTM A36 Fy=36 KSI
- STRUCTURAL STEEL MEMBERS SHALL BE SHEARED, FORMED, PUNCHED, WELDED, AND PAINTED BY THE MANUFACTURER. ALL SHOP CONNECTIONS SHALL BE WELDED IN CONFORMANCE WITH STANDARDS BASED UPON THE CURRENT EDITION OF ANSI/AWS D1.1. WELDERS AND WELDING OPERATORS SHALL BE QUALIFIED AS PROVIDED IN THE CODE.

**CONCRETE:**

- DESIGN AND CONSTRUCTION IN COMPLIANCE TO ACI 318-14.
- STEEL REINFORCEMENT IN CONCRETE ASTM A615 GRADE 60.
- COMPRESSIVE STRENGTH AT 28 DAYS: f'c=2500 PSI MIN.
- PROVIDE A MINIMUM 3" CONCRETE COVER OVER ALL EMBEDDED STEEL.
- CONCRETE MUST BE POURED AGAINST UNDISTURBED EARTH SOIL.
- SOIL PASSIVE PRESSURE PER CBC CLASS 5 (100 PCF).

**GENERAL NOTES:**

- ALL WORK SHALL BE IN ACCORDANCE WITH THE LATEST EDITIONS OF THE STANDARD SPECIFICATIONS FOR PUBLIC WORKS CONSTRUCTION, THE 2019 CALIFORNIA BUILDING CODE (CBC), AND 2018 INTERNATIONAL BUILDING CODE (IBC).
- ANY CONFLICTS BETWEEN THESE DRAWINGS, STANDARDS NOTED HEREIN, PROJECT REQUIREMENTS, AND/OR OTHER REFERENCE DOCUMENTS SHALL BE BROUGHT TO THE ATTENTION OF THE CIVIL ENGINEER, WHERE CONFLICTS OCCUR, THE MOST STRINGENT REQUIREMENTS SHALL BE FOLLOWED.
- PROVIDE ISOLATION OF DISSIMILAR MATERIALS

**BASE PLATE DESIGN:**

Mu=	5.684 k-ft	Size:	t:	0.75 in	Nominal Yield Moment	Mnp=Fy*Z:	20.25 k-in
Vu=	1.83 kip	S:	8 in		φ <sub>s</sub> :	0.9	
Tgrp:	8.53 kip	Arm:	2 in		φ <sub>s</sub> M <sub>np</sub> :	18.23 k-in	
Tb=	4.26 kip/bolt	b <sub>eff</sub> :	4 in		Demand/Capacity:	0.47 OKAY	
Mu PL=	8.5 k-in	n:	2 bolts				
S (in <sup>2</sup> )=	0.375	Steel A36			Nominal Yield Moment	Mnp=Fy*Z:	20.25 k-in
Z (in <sup>2</sup> )=	0.563	F <sub>tuw</sub> :	36 ksi		φ <sub>s</sub> :	0.9	
		F <sub>tyw</sub> :	36 ksi		φ <sub>s</sub> M <sub>np</sub> :	18.23 k-in	
		F <sub>cyw</sub> :	36 ksi		Demand/Capacity:	0.47 OKAY	
		K <sub>t</sub> :	1				

**STARBUCKS DRIVE THRU SIGNAGE**  
**5-PANEL MENU BOARD**  
 VARIOUS LOCATIONS, CALIFORNIA

PREPARED FOR: SIGN INDUSTRIES, INC.

CHECKED BY:	YR	JOB NO:	2131-00	SHEET:	1 OF 1
DISREGARD PRINTS BEARING EARLIER REVISION DATES			10-11-21		

**PREPARED BY:**

YR ENGINEERING LP  
 424 E. MAITLAND ST. STE. A  
 ONTARIO, CA 91761  
 PHONE: (626) 374-5881  
 EMAIL: YRAMOS@YRENGINEERING.COM

**REGISTERED PROFESSIONAL ENGINEER**  
 YOSIMAR RAMOS  
 No. 89832  
 Exp. 6/30/23  
 CIVIL  
 STATE OF CALIFORNIA

*Yosimar Ramos*  
 YOSIMAR RAMOS  
 R.C.E. 89832  
 LIC. EXP 06/30/23

- 8"x4"x3/16" SQ. HSS FRAME PER ELEVATION AND BASE PLATE DETAIL HEREON.
- 3/4" THK. STEEL BASE PLATE (18"x14") PER BASE PLATE DETAIL HEREON.
- (4) 1/2" THREADED HOT DIPPED GALVANIZED ANCHOR RODS (ASTM F1554 GRADE 55) WITH GALVANIZED HARDWARE PER ELEVATION AND BASE PLATE DETAIL HEREON.
- HORIZ: (5) #3 TIES AT 3" O.C. AND THEN (6) #3 TIES AT 10" O.C.  
 VERT: (8) #5 BARS SPACES EVENLY AROUND PERIMETER CLEARANCE 3" MIN. TO EDGE OF CONG.
- CONCRETE FOOTING PER PLAN AND SPECIFICATIONS HEREON.